

No 5573.149

256-264







# Manual for Teaching Midwives



United States Department of Labor  
Children's Bureau Publication No. 260



# Manual for Teaching Midwives

By

ANITA M. JONES, R. N.



Bureau Publication No. 260

UNITED STATES DEPARTMENT OF LABOR  
CHILDREN'S BUREAU  
WASHINGTON

1941

United States Government Printing Office, Washington : 1941

---

For sale by the Superintendent of Documents, Washington, D. C. - - - Price 30 cents





## Contents

	Page
Foreword.....	v
Planning an institute.....	
Teaching equipment.....	
The midwife's standard equipment.....	
Lesson I.—The midwife and her service to mothers.....	2
II.—Inspection of the midwife's standard equipment.....	3
III.—The prenatal period.....	3
IV.—Making the supplies.....	4
V.—The mother's preparation for delivery.....	4
VI.—Making a delivery bed.....	5
VII.—The midwife's preparation of herself.....	5
VIII.—The hand scrub.....	6
IX.—Labor.....	6
X.—The soapsuds enema.....	7
XI.—The care of the baby's eyes.....	8
XII.—The midwife's management during the first stage of labor.....	8
XIII.—The midwife's management during the second stage of labor.....	9
XIV.—Some midwife procedures during the second stage of labor.....	11
XV.—The midwife's management during the third stage of labor.....	11
XVI.—A practice period.....	12
XVII.—Aftercare of the mother and baby.....	12
XVIII.—The birth certificate.....	13
XIX.—A review.....	13
XX.—A practice period.....	13



## Illustrations

[Illustrations marked \* from New York Maternity Center Association]

	Page
FIGURE 1. Arrangement of the classroom.....	3
2. Closed bag.....	6
3. Open bag, lining over the edge, and each article laid out on the table.....	7
4. Bag showing arrangement of contents.....	8
5. Bag showing closed lining.....	9
6. Pattern of lining for bag.....	11
7. Completed lining of bag.....	11
8. Midwife's apron. Three views.....	12
9. One of the four muslin cases. Two views.....	13
10a. Pattern for midwife's cap.....	14
10b. Completed cap.....	14
11. Pattern of mask.....	15
12. Folding the cheesecloth for the mask.....	15
13. Completed mask.....	15
14. Making one gauze sponge for cord dressing. Step 1, two views.....	16
15. Making one gauze sponge for cord dressing. Step 2, two views.....	16
16. Making one gauze sponge for cord dressing. Step 3, two views.....	17
17. Making one gauze sponge for cord dressing. Step 4, two views.....	17
18. Completed cord dressing consisting of two sponges.....	17
19. Making paper wrapper.....	18
20. Making paper wrapper.....	18
21. Placing contents in wrapper. Five views.....	19
22. Package completed for sterilization. Five views.....	20
*23. Doctor's examination. Ten views.....	23
24a. Outcome of pregnancy in untreated syphilis.....	30
24b. Outcome of pregnancy—syphilitic pregnant women receiving treatment for 5 months or more during pregnancy.....	30
25. Model of brassiere supporting breasts.....	39
*26. Making newspaper bag. Four views.....	43
*27. Making newspaper pan. Three views.....	43
*28. Making newspaper pads. Three views.....	44
*29. Making sanitary pads. Six views.....	45
*30. Making cotton balls. Three views.....	45
*31. Supplies for delivery.....	47
*32. Supplies for the baby.....	49
*33. Board placed under mattress in preparation for delivery.....	52
34. Room arranged for delivery.....	52
35. Mattress protected by newspapers.....	56
36. Bed made with newspaper pads and newspaper pan.....	57
37. Equipment for scrubbing hands.....	62
38. Two views of bony ring.....	65
39. Demonstrating first stage of labor with bag and doll—how uterine contractions open the cervix. Two views.....	68
40. Demonstrating first stage of labor with bag and doll—why “bearing down” during first stage does not help.....	69
41. Relation of full bladder and full bowel to position of baby's head.....	77
42. Preparation for enema.....	79
43. Funnel and pinched tube used for enema.....	80

	Page
FIGURE 44. Giving enema.....	81
45. Care of the baby's eyes.....	83
46. Putting drops in the baby's eyes.....	86
47. Equipment in kitchen for second stage of labor.....	94
*48. Equipment in bedroom for second stage of labor.....	95
49. Mother "pushing".....	98
50. Opening sterile package. Four views.....	99
51. Supplies on table in delivery room.....	100
52. Opening sterile package.....	101
53. Birth of the head. Four views.....	102
54. Holding up baby by his heels.....	103
55. Position of baby before cord is cut.....	104
56. Feeling the throbbing cord.....	105
57. Tape with knot at one end.....	106
58. Tying first loop of square knot. Step 1.....	106
59. Tying first loop of square knot. Step 2, two views.....	106
60. Tying first loop of square knot. Step 3.....	106
61. Tying first loop of square knot. Step 4.....	107
62. Tying first loop of square knot. Step 5.....	107
63. Tying first loop of square knot. Step 6.....	108
64. Tying second loop of square knot. Step 1, two views.....	108
65. Tying second loop of square knot. Step 2.....	108
66. Tying second loop of square knot. Step 3.....	108
67. Two cord ties in place.....	109
68. Picking up scissors to cut cord.....	109
69. Cutting cord between ties.....	110
70. Looking for bleeding from stump.....	110
71. Retying cord.....	111
72. Putting on cord dressing.....	111
73. Cutting ends of tape.....	111
74. Applying second sponge.....	112
75. Applying binder.....	112
76. Baby in receiving blanket.....	113
77. Baby in bed.....	114
78. The afterbirth. Two views.....	120
*79. Placing mother on clean newspaper pad.....	124
*80. The first nursing.....	125
81. Nursing the baby.....	132

## Foreword

This manual was prepared by Anita M. Jones, R. N., nurse-midwife, assistant director of the Maternity Center Association, New York City, for the use of nurse-midwives and others responsible for the supervision and instruction of untrained midwives under the auspices of State and local health departments, to teach them: (1) to use aseptic techniques; (2) never to interfere with the delivery of the baby; (3) to call the doctor at the first sign of danger. As the number of women being delivered by untrained midwives, though considerable, is reported to be steadily decreasing, this plan of instruction for midwives is directed only toward meeting the acute need for improving the standards of the untrained midwives now practicing until they can be replaced by nurse-midwives or physicians. Thus it may have a place in improving the maternity care offered in a transition period, while efforts continue toward putting into practice throughout the United States a standard of maternity care that calls for skilled medical and nursing services for every mother, or at least the services of the nurse-midwife in localities for which it is not practicable to provide skilled medical services.

It is hoped that this manual will assist the nurse-midwife in the technical teaching and supervision which she gives to the practicing midwives who have not had special training and preparation. It is not in any way a textbook on midwifery, nor can the classes for midwives that are based on it be considered as "courses in midwifery." It is written simply, with frequent use of colloquial terms, so that the nurse-midwife will be able to present her instructions in language that the midwife will understand—the midwife who is without training and without formal education, who often can neither read nor write.

Undoubtedly there are many untrained midwives now practicing who cannot be taught all the material in this manual. Even when untrained midwives have been taught according to this manual they will not be adequately trained attendants at delivery. It is hoped, however, that their work will be less hazardous to the patients than it now is, because they will have been given some instruction in the elementary principles of personal hygiene and asepsis as well as improved techniques. Their responsibility for securing medical examinations for the women

in their care and for calling a doctor when any abnormal condition develops is of course constantly stressed.

As the midwife usually works alone, the procedures have been developed as far as possible so as to show her how to maintain good standards while working without assistance during normal labor and delivery, usually in very simple surroundings.

It is realized that the standards for equipment and procedure recommended here are in some instances below those required in States where the practicing untrained midwives have had supervision and instruction. Frequent revisions to raise the standards set forth in the manual will be essential if it is to continue to be useful.

Sincere thanks go to the doctors, nurses, and midwives whose cooperation made the preparation of this manual possible; to the Maternity Center Association of New York City for permission to use cuts from its publications and for consultation and criticism during the preparation of the text; and to the National Tuberculosis Association, the American Social Hygiene Association, and the National Society for the Prevention of Blindness for criticism of the text relating to their respective subjects.

# Manual for Teaching Midwives

---

## Planning an Institute

This manual covers the classes, demonstrations, practice periods, and teaching equipment for an institute for midwives. The teaching will be more successful if the following conditions are assured when the institute is being planned.

### **a. A small group of midwives.**

Because the midwives are, for the most part, unused to learning from group instruction the group should be kept small enough for the supervisor who is conducting the institute to give individual attention to each midwife. This is practically impossible if there are more than 15 in the group, and it can be done most satisfactorily if there are not more than 10. It will be necessary, therefore, to hold institutes for each group of 10 to 15 midwives in the area covered by the State or county supervisor of midwives who is giving the institute. In selecting the town and the group for each institute the transportation facilities that will be available for each midwife should be considered so that her capacity to learn will not be reduced by the fatigue of long, tiresome travel.

### **b. Simple informal classes.**

The talks should be so simple and direct that the midwives will feel free to discuss their problems and question anything that is not clear to them. Their confidence must be gained in the first session so that they will lose any suspicion they may have had of the new and unknown. Their language and expressions may be used until they have learned the few commonly accepted medical terms that will make it possible for them to report intelligently to the doctors.

### **c. Realistic demonstrations.**

The setting for each demonstration, especially those on management during labor, should reproduce as far as possible the situations in which the midwife will work. This means that the teaching equipment should include only those things which the midwife will find in the homes, will teach the mother to prepare, or will bring with her in the midwife's

standard equipment. The housefurnishings can probably be assembled locally; the other articles have been planned so that they will pack for easy transportation in the supervisor's car. As patients cannot be produced to order for a demonstration, nor the actual processes of labor and delivery delayed or interrupted to allow time for questions and special emphasis, dolls must be used instead of a mother and a baby. Dolls especially made for demonstration purposes are best, but home-made rag dolls may be used. A cord fastened to a doll's abdomen with adhesive may be used as an umbilical cord.

The midwife's standard equipment should be exactly like the equipment the midwife is expected or required to use—spotlessly clean, freshly laundered or well pressed with a hot iron, in perfect working order, and conveniently arranged for use. The cap and gown should fit the supervisor who is demonstrating just as the midwife's should fit her, and every article should be like those in the standard equipment in size, shape, and quality. The packages should be marked "For demonstration only" so that they can never be mistaken for packages from the midwives' bags ready to use. The supervisor's wash dress should be fresh, clean, and simple; and rings, bracelets, and beads should not be worn. Finger nails should be short and rounded. Whenever possible the supervisor should act the part of the midwife, talking to one doll as if it were the mother and carrying out each procedure with perfect technique; she should describe graphically procedures that cannot be acted. It will take imagination and some rehearsing to make the demonstrations realistic. They should be prepared carefully and presented dramatically.

#### **d. Practice periods supervised.**

The work of each midwife as she practices the various procedures should be closely supervised so that no errors can creep into her practice unnoticed. If such errors are not discovered until later, they may have become fixed as bad habits that will have to be broken or they will spoil the new skills that the supervisor is aiming to help the midwife develop. No midwife should leave the institute until her technique is correct; if she makes a mistake, the supervisor should see that she immediately repeats the procedure and keeps on trying until she does it correctly.

If a midwife is unable to master certain techniques within the time allotted, a plan should be made with her for continuing the supervision until she does, and her permit to practice should be withheld until that time. A license should not be issued to a midwife who cannot learn these simple techniques.

Opportunities should be definitely planned to observe midwife technique on actual deliveries in the home, in order to assure the supervisor that the standards taught are being put into practice.



**e. Adequate quarters.**

The quarters for the institute should include a clean, light room large enough to seat the midwives comfortably and leave plenty of space to arrange the furniture to resemble a kitchen and an adjoining bedroom, both with space enough to move about in freely (fig. 1).

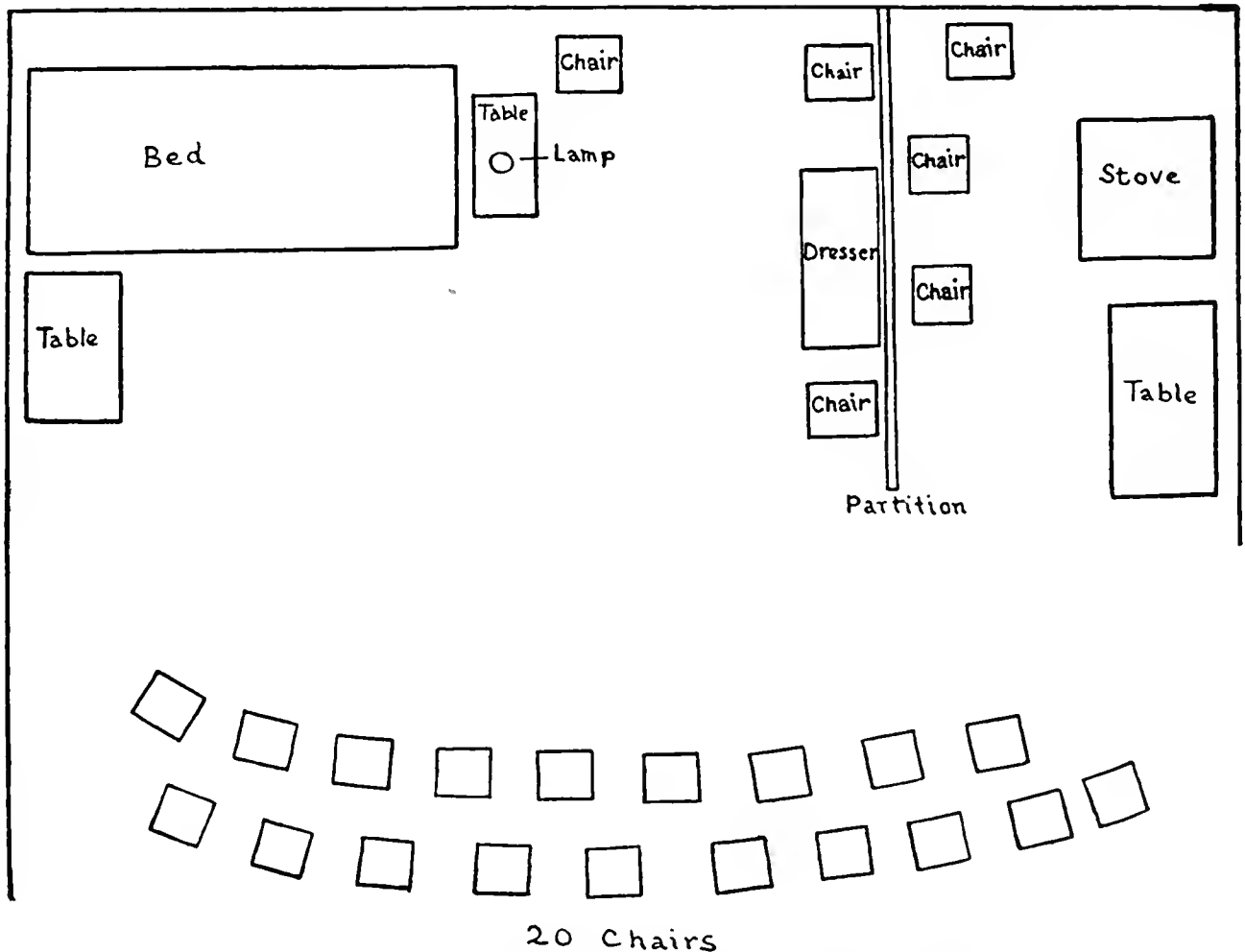

Fig. 1.—ARRANGEMENT OF THE CLASSROOM.

**f. The local workers informed in advance.**

All arrangements for the institute should be made by the State health department. The local hospital staffs, medical societies, doctors, and public-health nurses whose work may bring them in contact with the midwives should know in advance about the institute and should have copies of the manual. In this way they will know what the midwives are being taught and will be stimulated to help them and to keep the supervisor informed of points and procedures that need further emphasis or a new presentation.

**Teaching Equipment**

**To Be Obtained by the Local Nurse.**

**A. Furniture.**

- a. One large kitchen table.
- b. Six kitchen chairs.

- c. One four-burner or four-hole kitchen stove or a box painted to look like one.
- d. One single or double adult-size bedstead with springs, mattress, one pillow, six blankets, and one quilt.
- e. One table leaf or a clean, strong, smooth board about 1 inch thick, 12 inches wide, and as long as the width of the bed, to put under the mattress to prevent sagging.
- f. One dresser.
- g. Two small tables or stands.
- h. One lamp.

**B. Miscellaneous.**

- i. A stack of clean old newspapers at least 1 foot high.
- j. A supply of large sheets or a roll of wide wrapping paper to make clean covers for the kitchen table at least twice a day.
- k. Three or four dozen small sheets of wrapping paper to make covers for sterile packages.
- l. One new, unopened roll of toilet paper.
- m. Three flatirons, bricks, or sandbags to use for warming the beds.
- n. Twelve new cakes of white soap.
- o. Eight saucers, two cups, two plates, and two teaspoons.
- p. One washtub.
- q. One can of evaporated milk for making cocoa.
- r. One roll or package of paper towels.
- s. Strong rope to tie chairs together for baby's bed.

**To Be Carried by the Supervisor.**

- A. One copy of the midwife manual for each midwife.
- B. One standard midwife equipment. (See p. 6.)
- C. One doll to represent the mother.
- D. One doll to represent the baby.
- E. One doll with flexible cotton body and bald smooth head in a snug-fitting canvas bag closed with a double drawstring.
- F. Three dozen paper packages containing the cord ties, cord dressing, and cotton balls. Each package should be a perfect replica of the sterile package in the midwife's standard equipment but need not be sterilized. It should be marked "For demonstration only," so that it cannot be mistaken for a sterile package.
- G. One roll of gummed tape for sealing the packages (*F*).
- H. One spool of tape for making cord ties like the ones in the packages (*F*).
- I. One-pound roll of grade-A absorbent cotton for making cotton balls.
- J. Two dozen pieces of unbleached muslin 46 inches long and 36 inches wide for covers for newspaper pads.
- K. Six muslin covers for newspaper pads.
- L. Four sanitary pads made of old muslin, each wrapped separately in paper.
- M. One bag of clean white rags of various sizes for making wipes and sanitary pads, and for lining one thick newspaper pan and the receiving blanket.
- N. One ball of strong, white string for attaching to the baby doll for practice in tying the cord and in tying square knots.

- O.* One roll of 2-inch adhesive tape for attaching the cords to the baby doll.
- P.* Four dozen boxes of silver-nitrate ampules and needles.
- Q.* Two hand scrub brushes like the one in the standard midwife equipment.
- R.* Two wooden nail sticks like the one in the standard midwife equipment.
- S.* Four dozen birth-certificate blanks.
- T.* One enlarged copy of a birth-certificate blank 60 inches long and 40 inches wide for putting up on the wall.
- U.* Two dozen sharpened pencils.
- V.* One large teakettle.
- W.* One large cooking kettle with a lid.
- X.* Two 2-quart saucepans with handles and lids.
- Y.* One long-handled dipper.
- Z.* Six medium-sized hand basins.
- AA.* Four 10-quart buckets that will fit one inside the other.
- BB.* One 1-quart enamel pitcher.
- CC.* One large flat tin baking pan and a smooth board covered with a newspaper and placed across the end of the pan to make an improvised bedpan.
- DD.* One pair of ordinary household scissors.
- EE.* One iron holder.
- FF.* One covered jar of lard.
- GG.* One covered jar of sugar.
- HH.* One small can of cocoa.
- II.* Eight sheets.
- JJ.* Four pillowcases.
- KK.* Four towels.
- LL.* Two washcloths.
- MM.* Three nightgowns.
- NN.* One kimono.
- OO.* Two pairs of stockings (one white).
- PP.* One pair of bedroom slippers.
- QQ.* One comb.
- RR.* One tooth brush.
- SS.* Supplies for the baby:
  - a.* One shirt open down the front (size 2).
  - b.* One band made of outing flannel 6 by 27 inches.
  - c.* Six diapers 27 by 27 inches.
  - d.* One dress, kimono style, open all the way down the back.
  - e.* Three baby blankets 36 by 36 inches.
  - f.* One flannelette square, 36 by 36 inches.
  - g.* Two small, soft washcloths.
  - h.* Two soft old towels.
  - i.* One baby bed—a box 30 inches long, 18 inches wide, and 12 inches deep.
  - j.* One clean quilt for folding to make the mattress for the baby bed.
  - k.* Oilcloth or rubber pad to cover mattress.
  - l.* One pillowcase for covering the folded-quilt mattress and pad.
  - m.* One mosquito-net cover for the baby bed. (See pp. 49-50.)

- n.* One baby tray (see p. 53 and fig. 32) 12 by 15 inches, containing—
- (1) Five covered glass jars. (See p. 50.)
  - (2) One pint bottle for baby's boiled water, with stopper.
  - (3) One nursing bottle, 4-ounce size.
  - (4) Two nipples.
  - (5) One rubber cap for nursing bottle, or sterile cotton as stopper.
  - (6) Six large safety pins.
  - (7) Six small safety pins.
  - (8) One pint of mineral or cottonseed oil.
  - (9) One covered soap dish—a saucer with a cup turned upside down over the soap.

### The Midwife's Standard Equipment

The standard equipment for a midwife includes the articles that she will carry with her when she goes to deliver a mother and the bag in which they are to be carried. It is described here in detail so that the supervisor can assemble sample equipment for teaching purposes and be prepared to teach the midwife how to get her own equipment ready.

The bag and contents could be furnished or sold to the midwife by the State or county health department. They might be made according to specifications and sold by some reliable store at the State capital or the county seat. Perhaps the local Red Cross or some woman's club or sewing circle would make the gowns, caps, and so forth, according to specifications, and give or sell them to the supervisor to give or sell to the midwives.

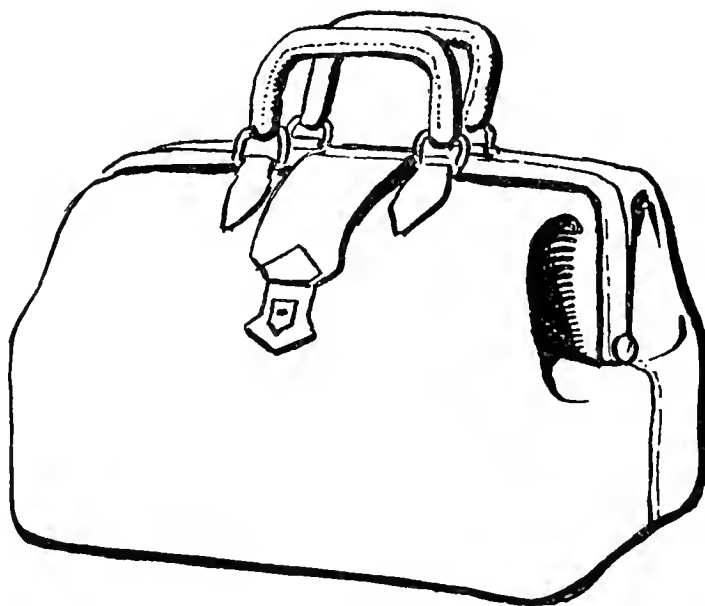

Fig. 2.—CLOSED BAG.

#### The Bag.

The standard bag is 14 inches long, 6 inches wide, and 10 inches deep. It is strongly made of top-grain cowhide that is durable and water-

repellent. The frame is strong and is so constructed that it can be closed tight or opened wide so that the contents can be removed easily. The frame hinges are so stiff and tight that the bag cannot spring closed but will hold itself open until it is closed purposely. It is unlined so that an inexpensive lining which can be removed for laundering can be used without adding unnecessary weight or cost (fig. 2).

**Contents of the Bag (fig. 3).**

- A. A separate muslin lining.
- B. A muslin-covered package containing a midwife apron.

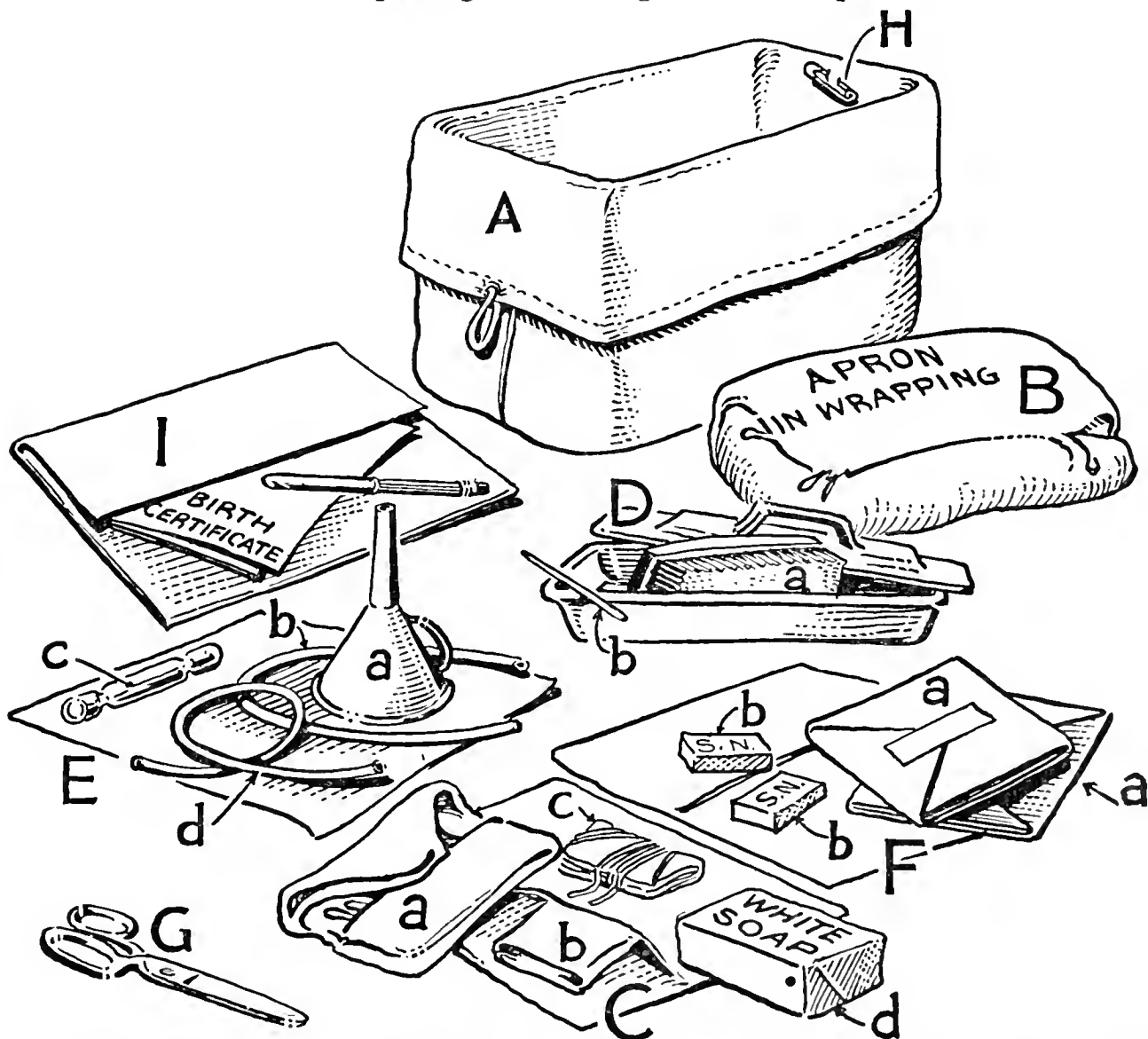

Fig. 3.—OPEN BAG, LINING OVER THE EDGE, AND EACH ARTICLE LAID OUT ON THE TABLE.

- C. A muslin case containing—
  - a. Cap.
  - b. Towel.
  - c. Mask.
  - d. Soap.
- D. A covered sterilizing basin containing—
  - a. Hand scrub brush.
  - b. Wooden nail cleaner.

- E.* A muslin case containing the following enema equipment:
- a.* Enamel funnel.
  - b.* Rubber tubing one-fourth inch in diameter and 18 inches long.
  - c.* Glass connecting nozzle.
  - d.* Rectal tube, size 26 French, 16 English, 19 American.
- F.* A muslin case containing—
- a.* Two sterile paper packages each containing—
    - (1) Two cord ties.
    - (2) Cord dressing.
    - (3) Six cotton balls.
  - b.* Two boxes of ampules of silver-nitrate solution.
- G.* One pair of blunt-point scissors that are sharp and tight.
- H.* One safety pin for fastening scissors to lining.
- I.* A muslin case containing—
- a.* Birth-record book.
  - b.* Birth certificates.
  - c.* List of registrars.
  - d.* Instruction sheets.
  - e.* Pencil with sharp point protected by a metal cap.

**A.** The lining is a box-shaped bag having a twilled-tape double drawstring and made of heavy unbleached muslin that will stand many launderings. (See p. 10.)

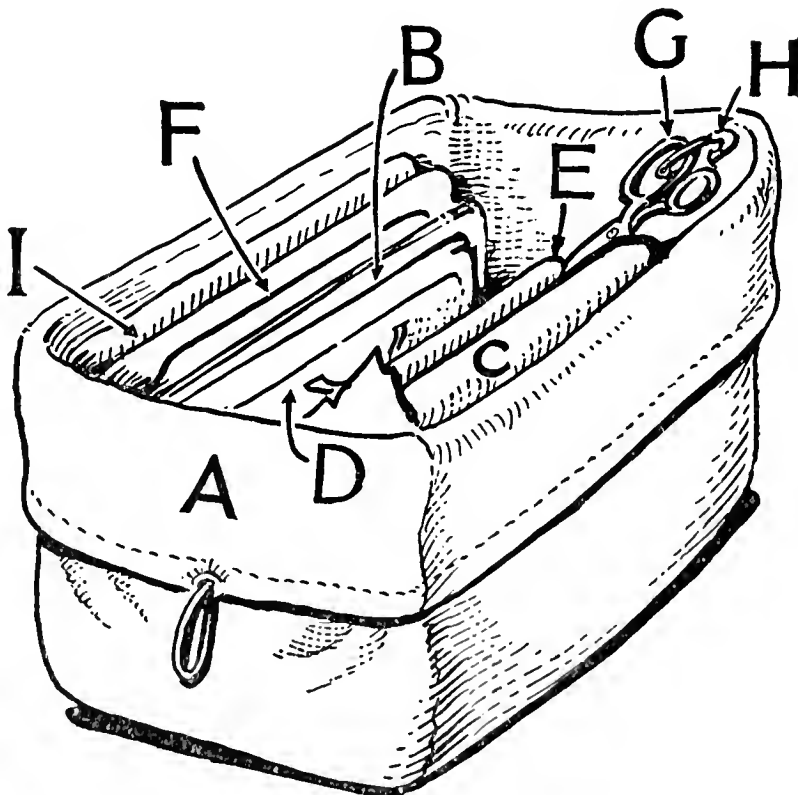

Fig. 4.—BAG SHOWING ARRANGEMENT OF CONTENTS.

It can be closed tight to protect the contents when the bag is to be closed, and fastened over the edge of the open bag to protect it (figs. 4 and 5).

**B, C, E, F, I.** The cover and cases are all made of the same heavy unbleached muslin, each one in the size that will protect its contents. (See p. 13.)

**B, C-a.** The apron and cap are made of heavy unbleached muslin and are large enough to cover completely the midwife's street dress and hair while she is caring for the mother. (See pp. 10, 13, and 14.)

**C-b.** The towel is 12 by 18 inches of huckabuck or crash (not bath toweling because that will not fold so flat nor look so fresh and clean when ironed).

**C-c.** The mask, made of four thicknesses of fine-weave bleached cheesecloth, is large enough to cover the midwife's mouth and nose well. The ties are long enough to hold it securely in place. (See pp. 13, 15.)

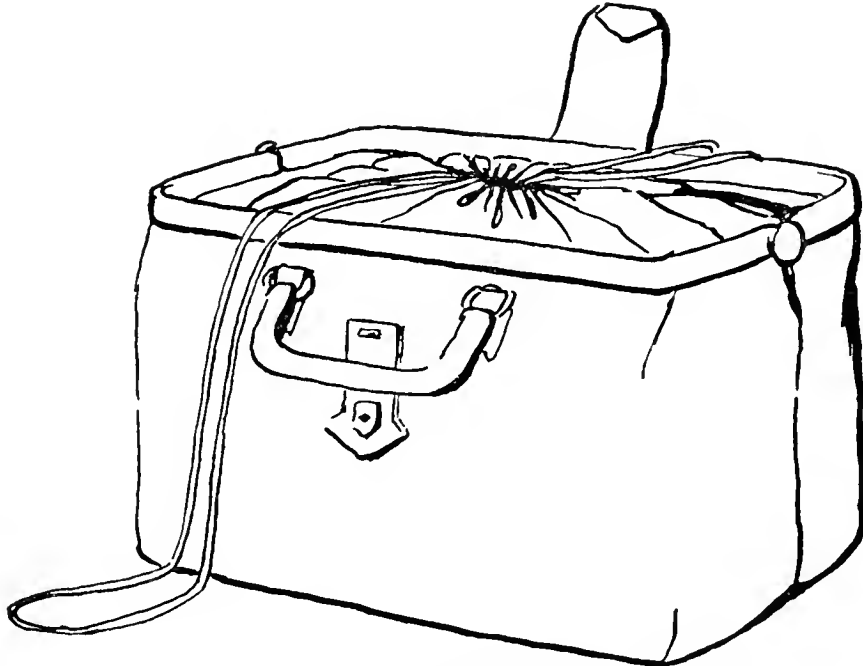

Fig. 5.—BAG SHOWING CLOSED LINING.

**C-d.** The soap for the midwife to use when scrubbing her hands is a new cake of white soap in the original wrapper. What is left she can use when laundering the things from her bag after a delivery.

**D.** The sterilizing basin with cover for boiling the scissors is of enamelware (which will not rust), 8 inches long and 3 wide.

**D-a.** The hand scrub brush for the midwife to scrub her hands with is a bristle brush that will keep its stiffness in spite of many boilings.

**D-b.** The wooden nail cleaner for the midwife's use when scrubbing her hands is an orangewood stick that can be scrubbed clean and boiled without getting rough or soft.

**E-a.** The enamel funnel in the enema equipment has an 8-ounce bowl and a stem 3 inches long that can be depended upon not to slip out of the rubber tubing.

**E-b.** The rubber tubing in the enema equipment should be of good-quality surgical tubing so that it will stand a great deal of boiling before it softens.

**E-c.** The glass connecting nozzle in the enema equipment is the same size at both ends. One that has a pointed end is more likely to break or slip.

**E-d.** The rectal tube in the enema equipment is of medium size. It is of good-quality rubber so that it will not soften when boiled.

**F-a.** The wrappers for the sterile packages are of tough, heavy wrapping paper sealed with gummed tape. (See pp. 17, 18.)

**F-a-1. The cord ties** are of woven tape one-eighth inch wide cut in 12-inch lengths, strong enough to hold and long enough to tie easily.

**F-a-2. The cord dressing** is made of two gauze "sponges" (see pp. 16-17) 4 inches square, to give adequate protection to the cord stump.

**F-a-3. The cotton balls** for wiping the baby's face are the standard large-size absorbent-cotton balls. (See p. 45.)

**F-b. The ampules of silver-nitrate solution** are the "eyedrops" supplied free by some State departments of health in boxes containing two wax ampules of solution and a needle for opening them. (See p. 84.)

**G. The cord scissors** are 5 inches long, strong, and sharp, with a tight screw so that they will cut easily and with blunt points so that there will be no danger of hurting the baby.

**H. The safety pin** is the ordinary medium-sized pin with a good clasp, for pinning the scissors to the bag lining.

**I-a. A birth-record book** in which the midwife can keep a record of her cases may be supplied by the department of health. The supervisor should inform the midwives what is the practice in their State.

**I-b. Birth certificates** for reporting births are supplied by local departments of health. The midwife will send to the proper registrar a certificate for every baby she delivers so that the State will have a record of the birth.

**I-c. The list of registrars** supplied by State departments of health informs the midwives with regard to the district covered by each registrar.

**I-d. The instruction sheets** are all the directions supplied to the midwives by the supervisors.

**I-e. The pencil** for the midwife to use in filling in her records should have a metal cap to protect the point.

### **Making the Supplies.**

Scrub the hands thoroughly before working on these supplies. Wash and iron the unbleached muslin before using. Eight yards will make the bag lining, apron, and cap, and the muslin cases.

**The lining (A).**—Take one strip of muslin 42 inches long and 15 inches wide and two strips 17 inches long and 9 inches wide (fig. 6).

Stitch 1 to 1a, 2 to 2a, 3 to 3a, 4 to 4a, 5 to 5a, and 6 to 6a; half an inch is allowed for each seam. Trim the seams close. Turn the bag and make all the seams French seams. After this stitching has been done trim the top edges even and put a 1-inch hem around the top of the bag.

At each end of the bag work a buttonhole through one thickness of this hem. Through one of these buttonholes run a drawstring of good-quality twill tape 54 inches long. The tape should go through the hem all the way around the bag so that both ends of the tape come out of the same buttonhole. Sew the ends of this tape together and tack this seam securely to the hem under this buttonhole. Pull the tape through the buttonhole at the other end of the bag so that it forms a loop and fits smoothly in the hem.

Through this buttonhole from which the loop now extends, run a second drawstring 54 inches long, sew the ends together and tack this seam securely to the hem under the buttonhole, pushing the loop of the other drawstring out of the way so



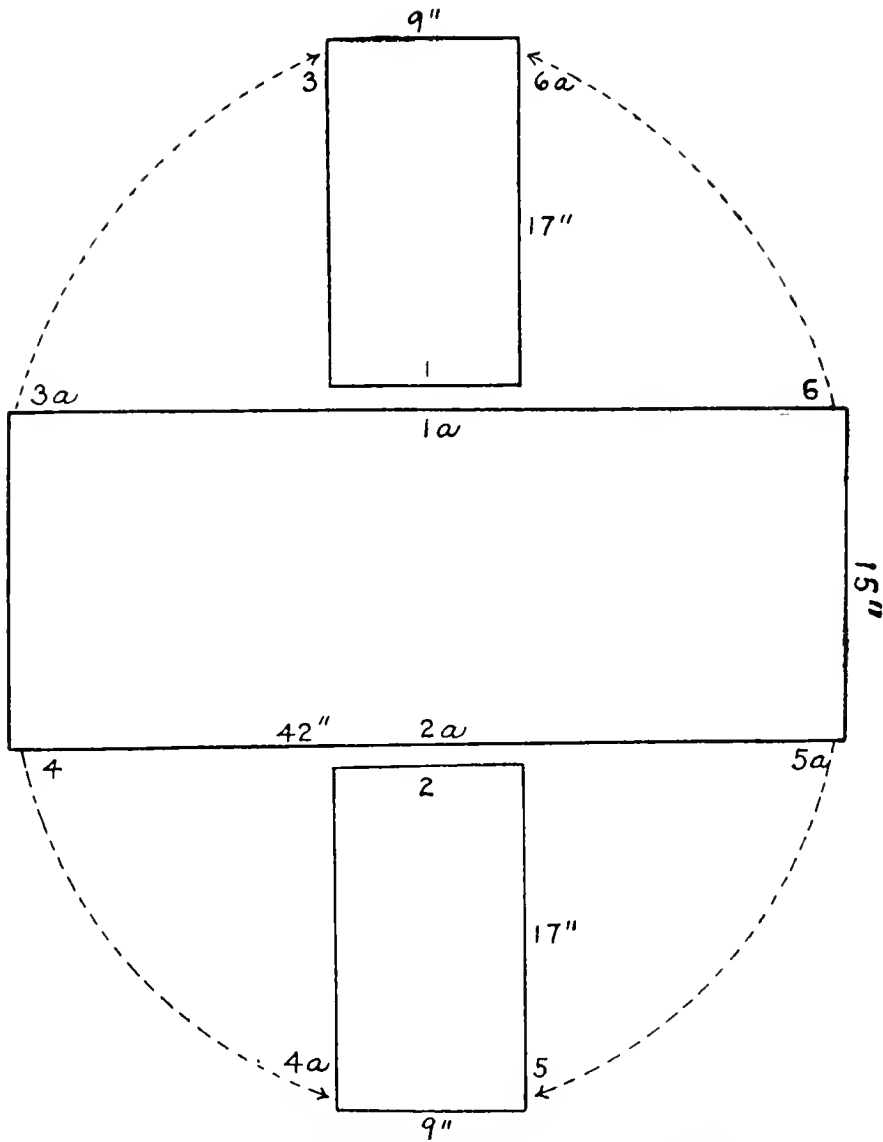

Fig. 6.—PATTERN OF LINING FOR BAG.

as not to catch it in the stitching. Pull the second drawstring through the button-hole at the opposite end of the bag so that it forms a second loop. The bag will close when the two loops are pulled (fig. 7).

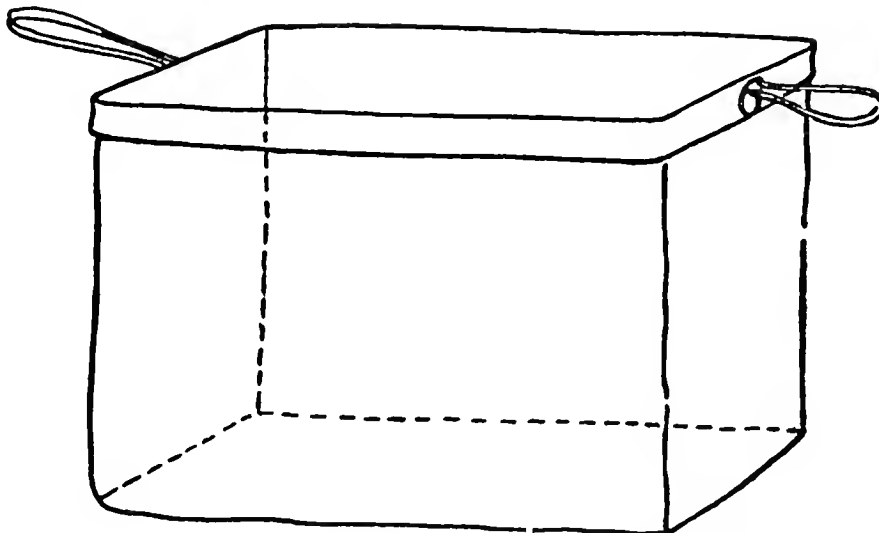

Fig. 7.—COMPLETED LINING OF BAG.

**The midwife apron (B).**—An apron with kimono sleeves requires two lengths of muslin cut long enough to allow  $2\frac{1}{2}$  inches for the hem.

If the midwife is large she should add a straight strip to each sleeve in order to have the sleeve long enough to reach just below her elbow. The apron should come well below the hem of her dress and well up to the neck line. There should be a belt—a 4-inch strip of muslin folded, stitched, and turned—stitched to the center front of the gown at the waistline. The neck should be bound with a straight strip 2 inches wide and fastened with tape ties 10 inches long sewed to each end of the neck band. The edges of the sleeves should be hemmed and should have pleats stitched in to make the sleeves fit at the elbows (fig. 8, three views).

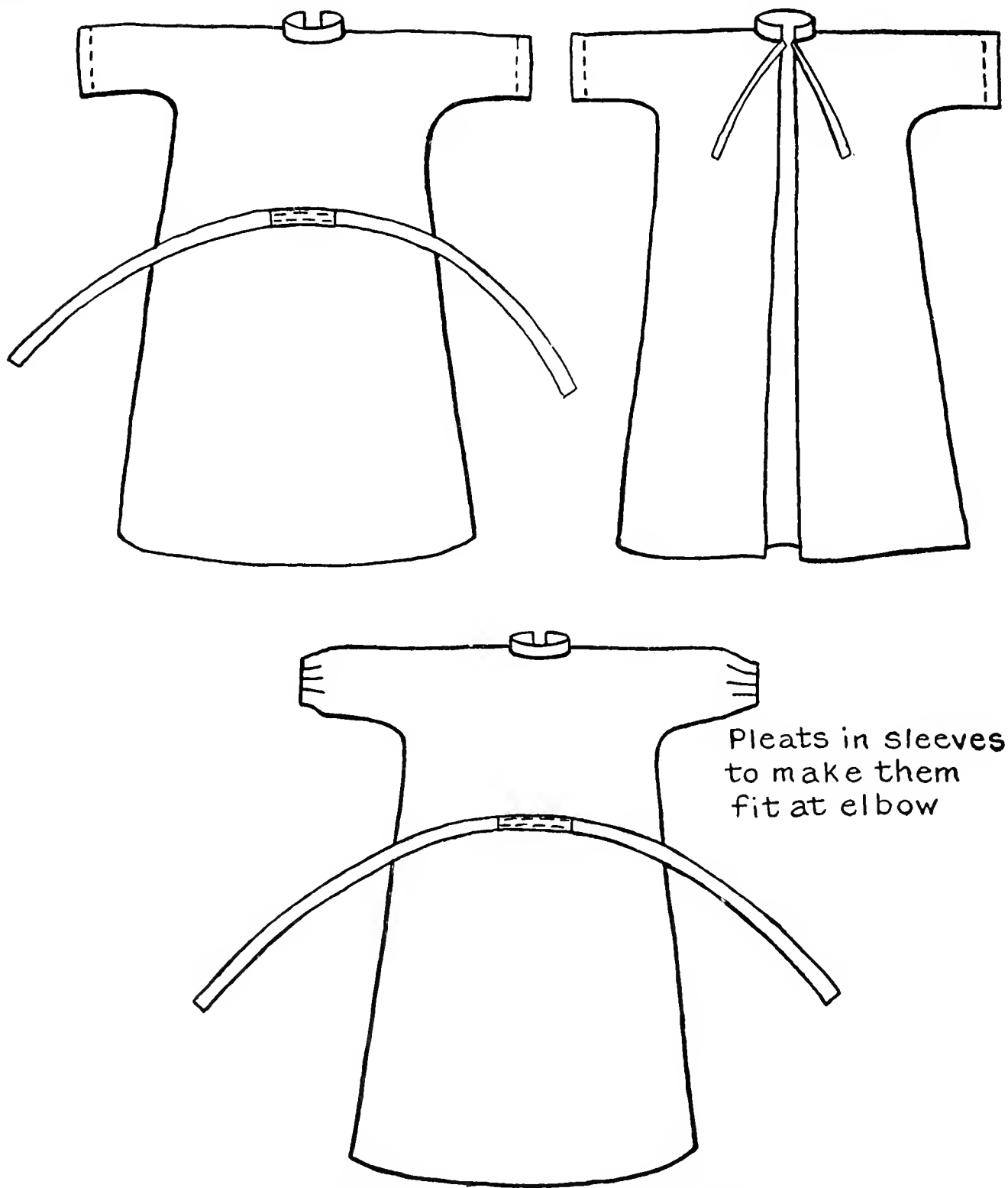

Fig. 8.—MIDWIFE'S APRON. THREE VIEWS.

The cover for the apron is a piece of muslin 24 inches square with a narrow hem.

The muslin cases (C, E, F, and I) are like envelopes 10 inches long and 7 inches wide with a 7-inch flap. To make each case take a strip of muslin 23 inches long and 12 inches wide. Hem it all around. To make the pocket, fold on AB

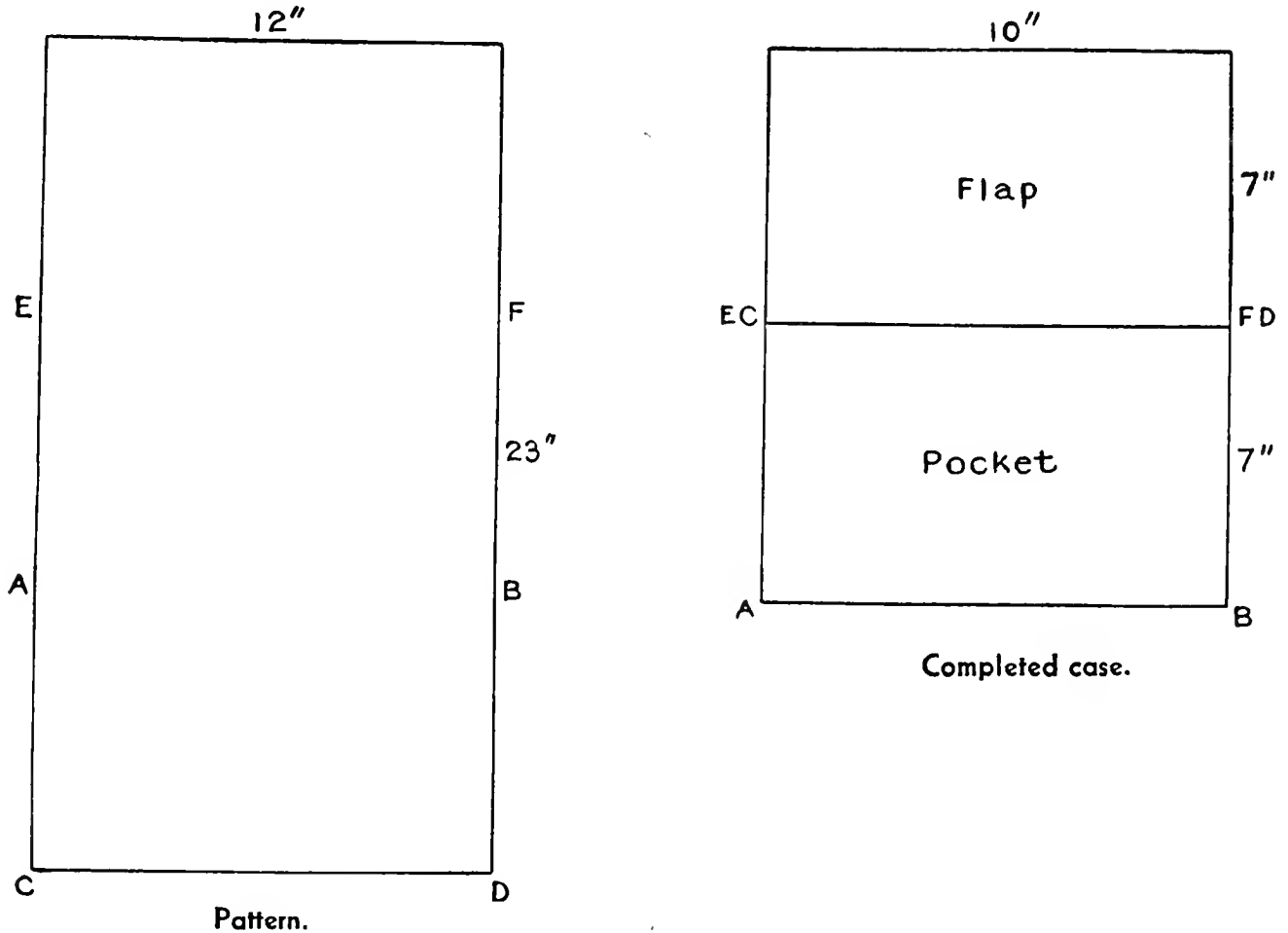

Fig. 9.—ONE OF THE FOUR MUSLIN CASES. TWO VIEWS.

shown in figure 9, bringing C to E and D to F. Stitch the two ends from EC to A and from FD to B.

**The cap (C-a).**—Cut out a circle of material 12 inches in diameter. A plate of this size can be used to make the circle. Measure off a strip of material 8 inches wide and  $1\frac{1}{2}$  inches longer than is needed to fit around the head. Seam the ends of the band together. Mark the circle of material into fourths. Do the same with the head band. Put the marks together. Pleat or gather the circle onto the band evenly between the marks (figs. 10a and 10b). Turn the band and hem it down flat.

**The mask (C-c)** is made of fine-weave, bleached cheesecloth folded to make four thicknesses 9 inches long and  $5\frac{1}{2}$  inches wide. Cut a 6-inch strip off a double cheesecloth roll so as to have a double piece of material 18 inches long and 6 inches wide with selvages on one side and the fold on the other (fig. 11). Turn in one-fourth inch on each of the two raw edges. Fold the material in half from end to end (fig. 12). Gather the sides, ADBC and XY, until they are 3 inches wide. Cut two pieces of tape 9 inches long and bind the top and bottom edges of the mask. Cut two pieces of tape each 29 inches long and bind the sides, leaving 13 inches at each corner for the ties (fig. 13).

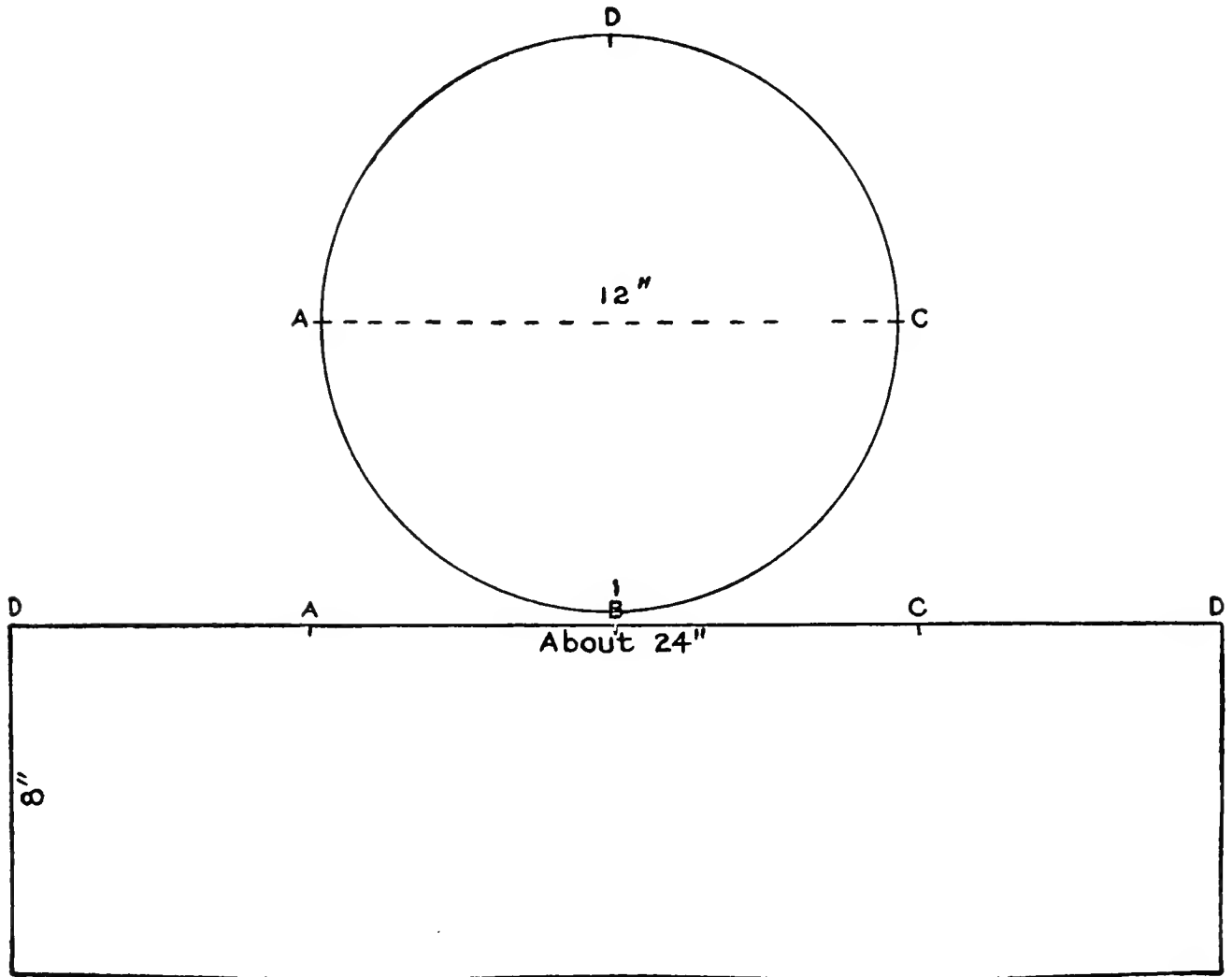

Fig. 10a.—PATTERN FOR MIDWIFE'S CAP.

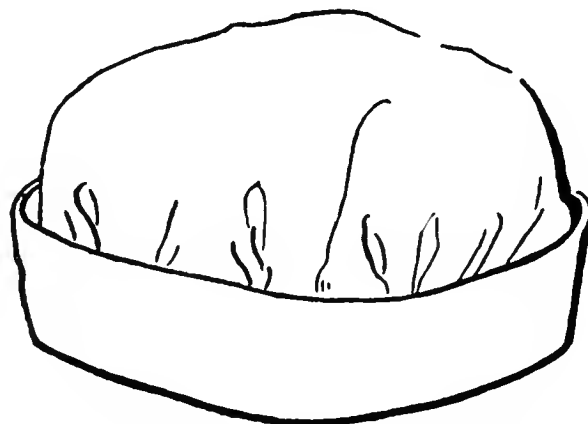

Fig. 10b.—COMPLETED CAP.

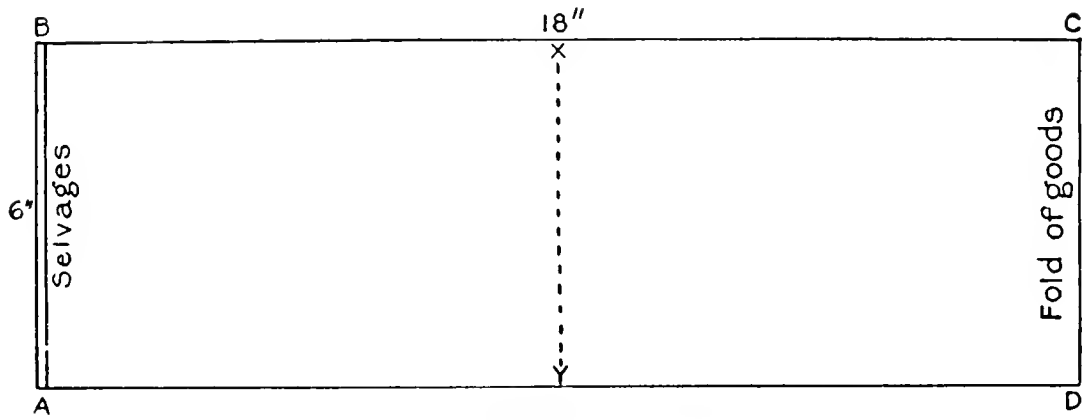

Fig. 11.—PATTERN OF MASK.

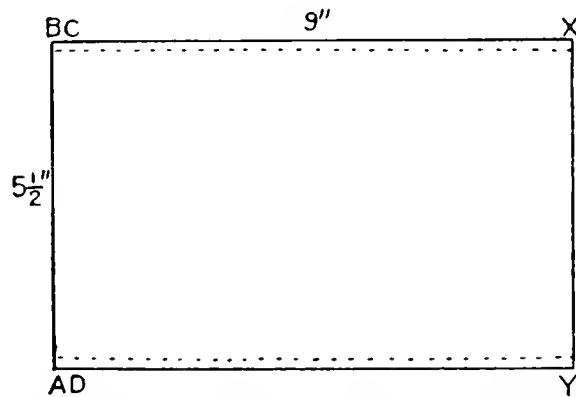

Fig. 12.—FOLDING THE CHEESECLOTH FOR THE MASK.

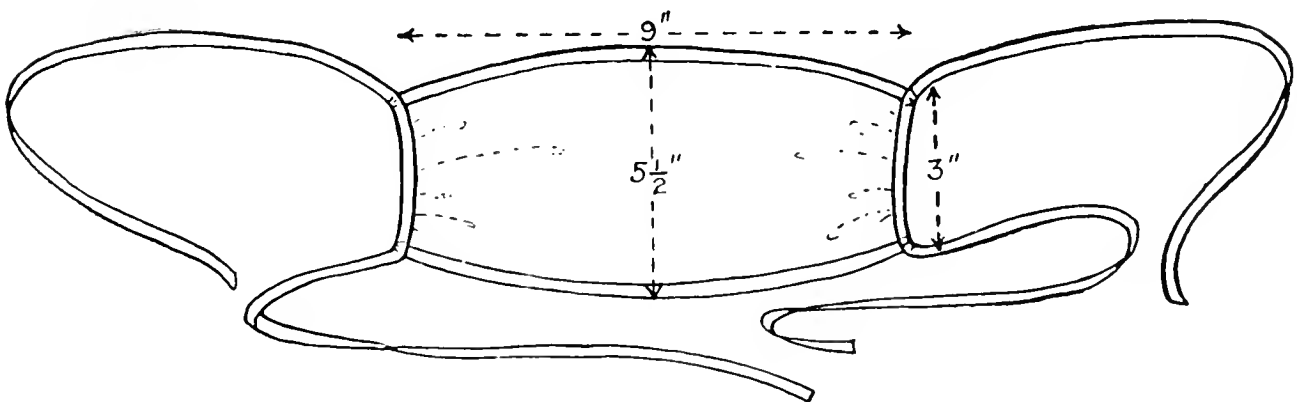

Fig. 13.—COMPLETED MASK.

**The cord dressing (F-a-2).**—Cut two pieces of surgical gauze 16 inches square. From each piece make a 4-inch square “sponge” as follows:

Step 1.—Fold side AB on dotted lines to center. Fold side CD on dotted lines to center (fig. 14, two views).

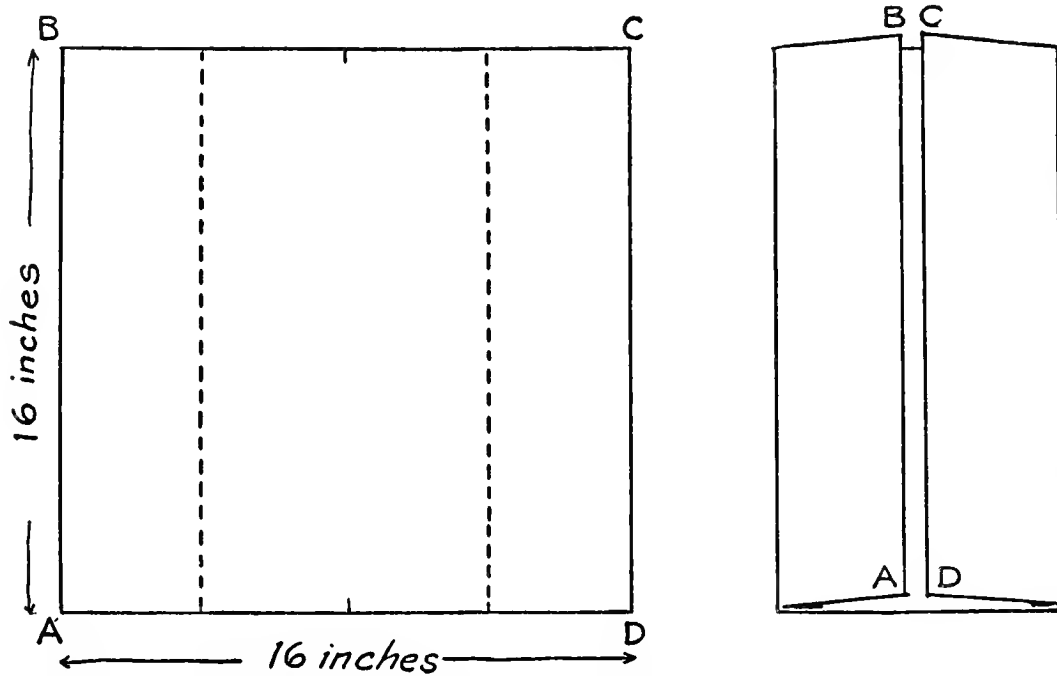

Fig. 14.—MAKING ONE GAUZE SPONGE FOR CORD DRESSING. STEP 1, TWO VIEWS.

Step 2.—Fold side EG on dotted lines to center. Fold side FH on dotted lines to center (fig. 15, two views).

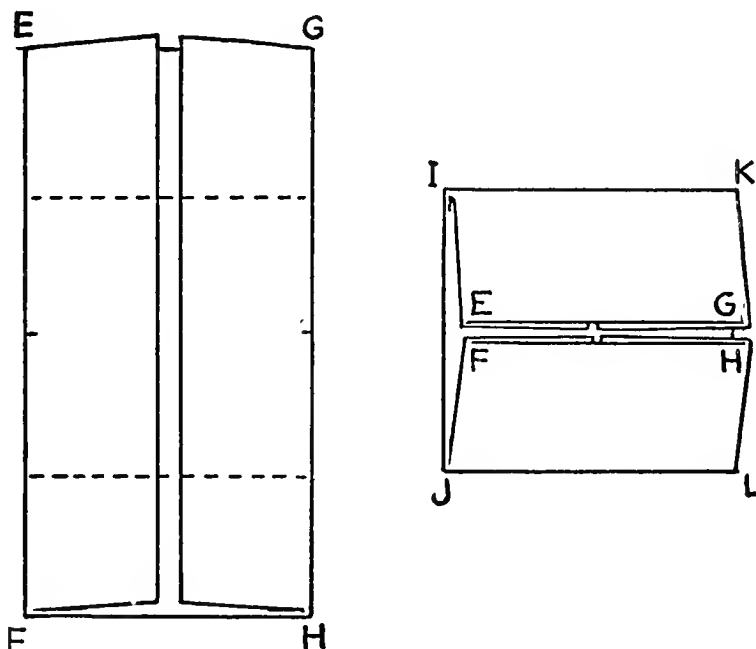

Fig. 15.—MAKING ONE GAUZE SPONGE FOR CORD DRESSING. STEP 2, TWO VIEWS.

Step 3.—Fold in half on dotted line, forming a rectangle 4 inches by 8 inches (fig. 16, two views).

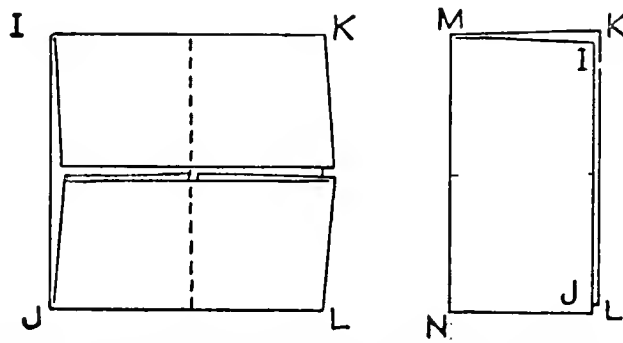

Fig. 16.—MAKING ONE GAUZE SPONGE FOR CORD DRESSING. STEP 3, TWO VIEWS.

Step 4.—Fold in half again on dotted line, forming a square 4 inches by 4 inches, with all raw edges folded inside (fig. 17, two views).

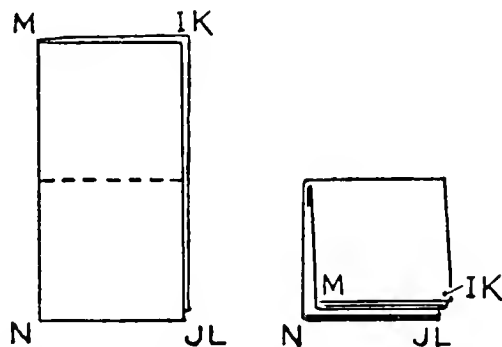

Fig. 17.—MAKING ONE GAUZE SPONGE FOR CORD DRESSING. STEP 4, TWO VIEWS.

Cut one sponge from one corner to the center. The two sponges, the one with the cut laid on top of the one without the cut, make one cord dressing (fig. 18).

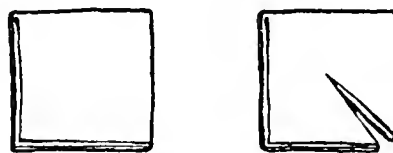

Fig. 18.—COMPLETED CORD DRESSING CONSISTING OF TWO SPONGES.

### Making the Sterile Package.

Make a paper wrapper as follows:

- Take a 16-inch square piece of clean, tough wrapping paper as a cover.
- Fold by bringing C to within 1 inch of A (fig. 19).
- Crease paper well so that the cross line will be well indicated (fig. 20).

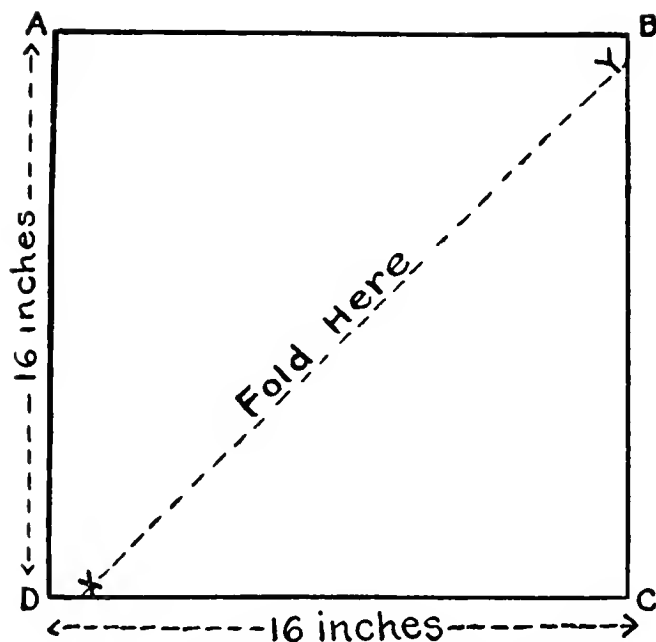

Fig. 19.—MAKING PAPER WRAPPER.

- Open the wrapper (fig. 21, five views) and place on it at the center of the crease—
- Two cotton balls.
  - One cord dressing (two 4-inch sponges, one split and the other not split).
  - Two cord ties, each laid separately on top of the dressing so that it can be picked up without touching the other one.
  - Four cotton balls laid on top of the other supplies.

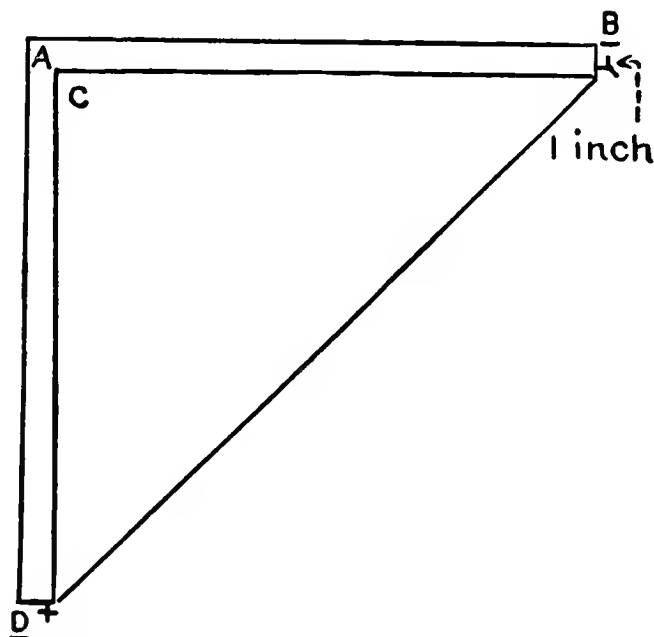

Fig. 20.—MAKING PAPER WRAPPER.

Wrap the package (fig. 22, five views) ready to be sterilized:

Fold on the crease XY.

Fold D toward B with the fold along EH close to the edge of gauze squares inside.

Fold B over beyond EH with the fold along FG close to the edge of the gauze squares inside.



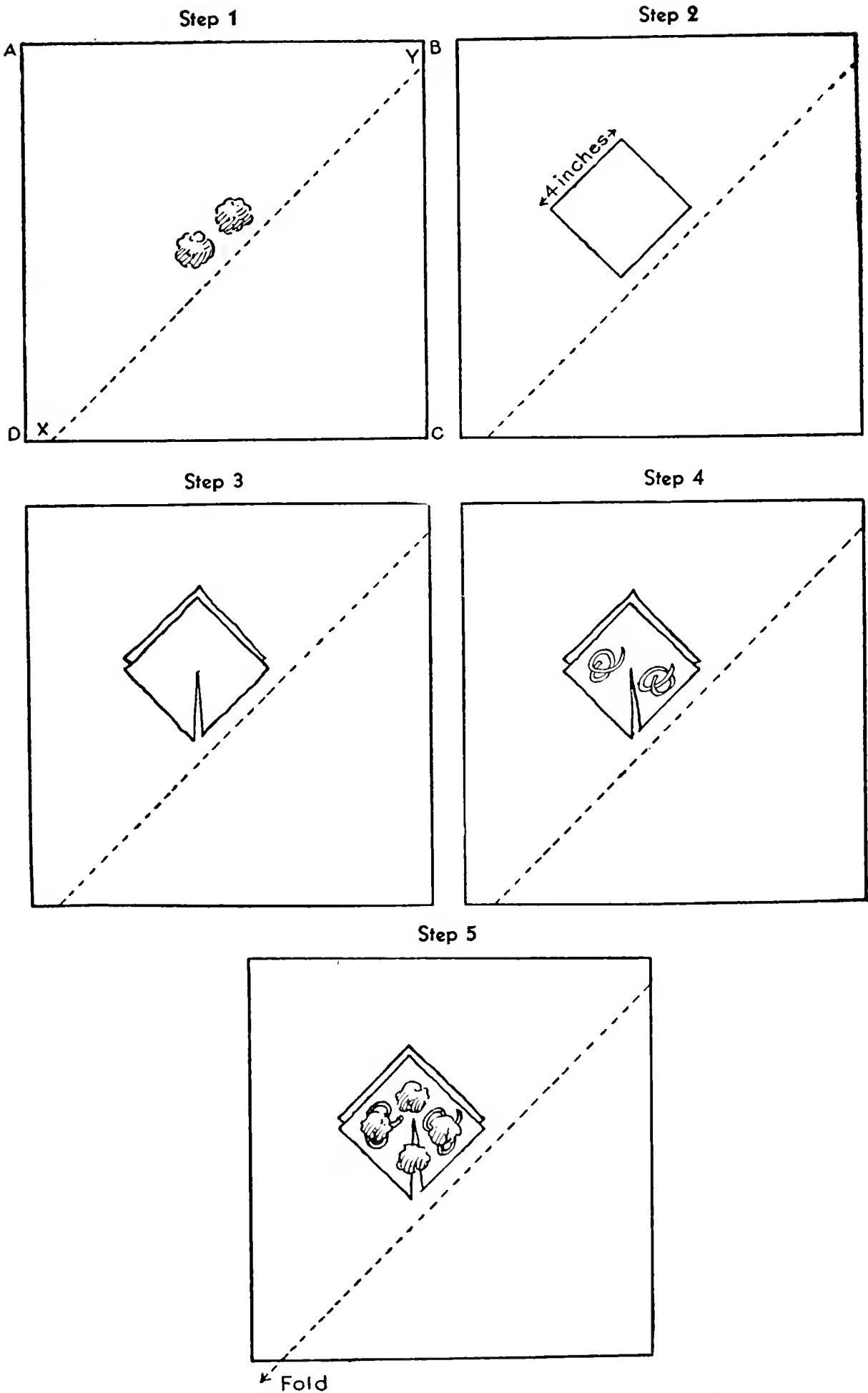

Fig. 21.—PLACING CONTENTS IN WRAPPER. FIVE VIEWS.

Fold B toward G with the fold along EH.

Fold B toward H along FG.

Fold A toward HG on IJ close to the edge of the gauze squares inside.

Fold A toward IJ on EF.

Seal A with a 3-inch strip of 1-inch gummed paper.

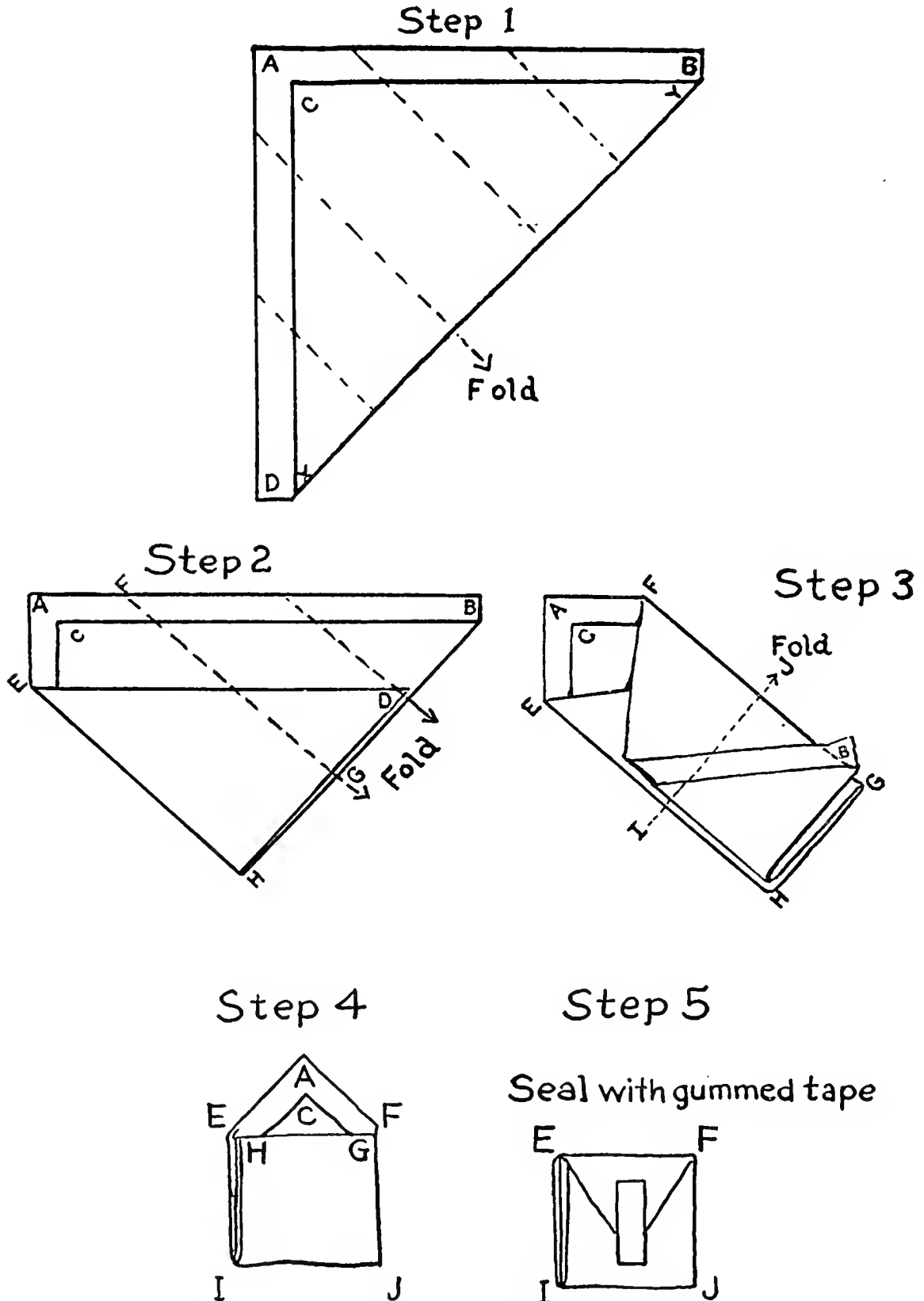

Fig. 22.—PACKAGE COMPLETED FOR STERILIZATION. FIVE VIEWS.

**To sterilize the package.**—Put in a slow oven beside a large raw potato. When the potato is well cooked the package will be sterilized.

### **Packing the Bag.**

The articles in the bag are wrapped or put in cases to keep them clean and arranged in the packages so that they are convenient to use. They are always packed in the bag in the same place and order so that the midwife can put her hand on the thing she wants without fumbling through the bag or handling all its contents.

Before a new bag is packed it should be wiped clean inside and outside with a clean cloth wrung out of hot, soapy water, rinsed with a cloth wrung out of clean, hot water, and then dried with a clean cloth. The new lining, apron, wrapper, cap, towel, mask, and muslin cases should be washed, boiled, dried in the sun, and ironed with a “spitting” hot iron. The sterilizing basin and cover, funnel, glass connecting nozzle, scissors, and safety pin should be scrubbed clean, rinsed with boiling water, and dried thoroughly. The hand scrub brush and the nail stick should be washed with soap and water, rinsed thoroughly, boiled, and set in the sun to dry. The rubber tubing and the rectal tube should be washed clean with soap and water, rinsed, and dropped into boiling water to boil for 3 minutes.

Place the bag, with the lock toward you and the contents on a table covered with clean paper. Open the bag wide so that it will stay open. Insert the lining, open it wide, and draw it over the edge of the bag.

Put the muslin case (I) containing stationery and pencil against the far side of the bag—the side to which the flap fastener is stitched. (See fig. 4, p. 8.)

Pin the scissors (G–H) to the right end of the lining.

Put the muslin case (F) containing the sterile dressings and silver nitrate next to and in front of I.

Put the muslin package (B) containing the apron next to and in front of F.

Put the muslin case (E) containing the enema equipment next to and in front of B.

Put the muslin case (C) containing the cap, towel, mask, and soap next to and in front of E.

Put the sterilizing basin (D) containing the nail stick and hand scrub brush on top of all the packages.

Release the bag lining from the edge of the bag and draw the strings tight (fig. 5, p. 9).

Close and fasten the bag.

## The Midwife and Her Service to Mothers

Most State laws define a midwife as any person other than a licensed physician who shall attend, or who shall bargain, contract, or agree to attend, any woman at or during childbirth. Many States require a midwife to apply for a permit before engaging in practice. The authority to issue midwife permits is usually vested in the State department or board of health.

A midwife when licensed is permitted to deliver only well mothers of full-term babies. Even where licenses are not required she **should** deliver only well mothers of full-term babies.

### The Midwife's Relation to the Mother

In many communities the midwife has special prestige because the service she renders is connected with the mystery associated in the minds of many people with the birth of a baby. Because the mothers are her neighbors and friends she usually knows about all the coming babies almost as soon as the mothers do. Her influence with the mothers throughout pregnancy is therefore a real force that can be used to improve maternity care.

### The Doctor's Examination

It is of first importance to teach the midwife why every pregnant woman should have a complete medical examination early in pregnancy. If she understands that no matter how much training and experience she may have had she can never safely care for a mother who has not had this medical examination, she will use her influence to persuade the mother to go to a doctor in his office or to a clinic early in pregnancy.

Explain that the line between sickness and health—danger and safety—is so very narrow that a doctor can know the condition of a woman only after he has made a complete and thorough examination (fig. 23, 10 views).

The modern midwife does not attempt to deliver a mother if she knows that the mother has any disease. When the doctor finds disease early in pregnancy, his examination will save the midwife from getting into trouble through caring for a sick mother. And the midwife can help the mother tremendously by urging her to follow the doctor's advice and

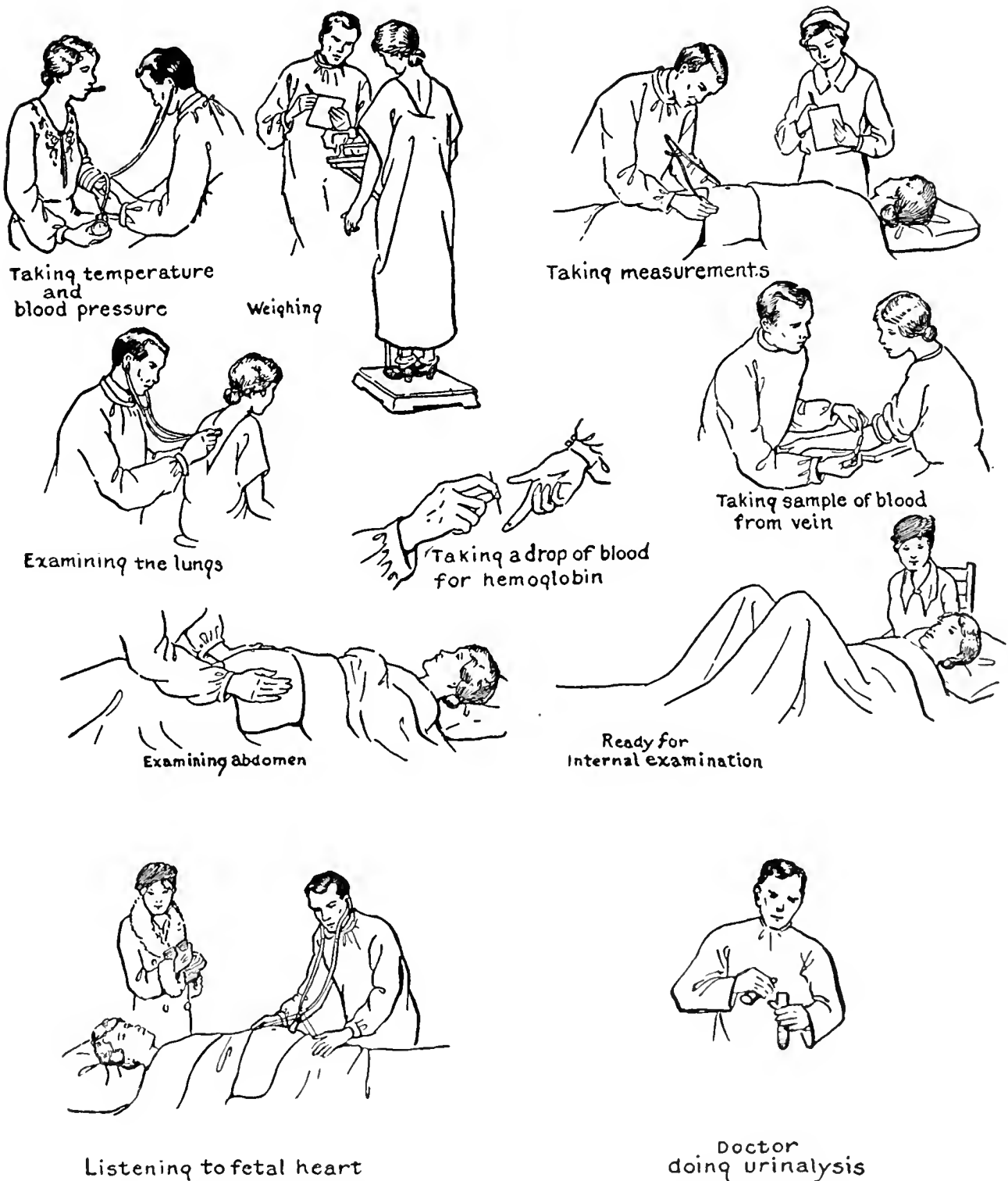

Fig. 23.—DOCTOR'S EXAMINATION. TEN VIEWS.

by explaining to her that it is the sickness we do not know about that is bad. The sickness a doctor finds early he can usually control, even if he cannot make the mother well enough for the midwife to deliver her. When the doctor advises medical care at delivery, the midwife will help by explaining to the mother why she cannot deliver her.

The doctor may find not illness but some weakness that can be entirely overcome by the right care during pregnancy. Then the mother, instead of getting sick as pregnancy progresses, will get well because the doctor found the weakness in time and the midwife helped the mother to follow

his advice. Under these circumstances, if the doctor consents, the midwife may deliver the mother.

It takes skillful measurement by a doctor or an X-ray picture of the bones of the birth canal to learn whether or not there is room in the mother's body for a full-term baby to be born without the help of instruments or surgery. If there is room, the midwife will gain confidence through knowing it. If there is not room, knowing it well ahead of time and planning for good hospital care may save the mother's and baby's lives.

So the intelligent midwife who understands how much she herself, as well as the mother and the baby, can benefit by the doctor's examination of the mother will spare no effort to get every pregnant woman to a good doctor early in pregnancy.

Be sure that the midwife understands how to get in touch with the county or city health unit when there are no private physicians to examine the mothers in her community.

### **Registering or Promising To Care for a Mother**

Before promising to care for a mother at childbirth a midwife should know that it is safe for her to attempt the delivery, should be reasonably sure that the mother is pregnant, and should know about when to expect the baby. The doctor is the only one who can tell whether or not the mother is well and has room for a full-term baby to be born without instruments. The midwife will explain to the mother these reasons why she should go to the doctor for a complete examination before the midwife can make plans to deliver her. The midwife may even take the mother to the doctor to be sure she does not put off going. She should see that the mother goes to the doctor for another examination in the eighth month of pregnancy.

First the midwife can discuss with the mother the **symptoms and signs of pregnancy** so as to be reasonably sure she is pregnant:

- A. Missing monthly periods.
- B. Tenderness and fullness of the breasts; tingling or prickling sensations in the breasts.
- C. Sick stomach, usually in the morning but sometimes in the afternoon or the evening.
- D. The abdomen (belly) getting bigger from week to week.
- E. Feeling the baby move after the fourth or fifth month.

Together they can **figure when to expect the baby** by counting back 3 months from the first day of the last menstruation and adding to

that date 1 year and 7 days. Example: If the last menstruation began January 1, 1934, counting back 3 months would bring us to October 1, 1933. If we add 1 year and 7 days we have October 8, 1934, as the expected date of confinement.

### Symptoms That Should Be Reported to a Doctor

Impress upon the midwife that, when the mother is well to begin with, pregnancy should be a normal, healthy experience but that it sometimes is not, and she must watch for signs of trouble. Pregnancy puts a strain on every structure in a woman's body, and sometimes, even when she was well early in pregnancy, she becomes ill as pregnancy progresses because this strain is too much for her heart or her kidneys or some other organ. Or some disease may develop during pregnancy just as disease develops at any other time.

Illness seldom comes during pregnancy without giving warning signs or symptoms, commonly known as the "danger signals" of pregnancy. Explain to the midwife that most of these symptoms, if "taken in time," can be controlled by a good doctor. That is why it is so important for the midwife to report to a doctor as soon as she discovers any of the danger signals.

The midwife who knows about these danger signals cannot fail to notice or to hear about them if she keeps her eyes and ears open as she goes about among her neighbors and friends. But she cannot leave to chance the discovery of danger signals in the mother she has registered. She is responsible for watching over her life from the day she registers her. She must see her at least once a month during the first 6 months, every 2 weeks or oftener in the next 2 months, and every week in the last month to be sure that a doctor is called if all is not going well with her.

Whenever a midwife thinks a doctor should be called, the first thing for her to do is to urge the family to call the doctor of their choice. If the family does not or cannot get a doctor, the midwife is responsible for reporting the situation to the county health unit or the town department of health. She should not put herself in the false position of seeming to care for a mother who needs medical attention without having called a doctor.

**Toxemia.**—Explain to the midwife the seriousness of the following symptoms, which may mean "kidney trouble" or toxemia:

- A. Spots before the eyes.
- B. Inability to see well, haziness before the eyes, blurring of vision, or dizziness.
- C. Severe or persistent headache.

- D.* Swelling of the ankles, feet, hands, eyelids, or face.
- E.* Cramping pains around the pit of the stomach.
- F.* Scant urine (passing little water, which may have a somewhat dark color) or inability to void (pass water).
- G.* Vomiting.
- H.* Great gain in weight.
- I.* Muscular twitching. (See p. 38.)

If any of these symptoms appear at any time during pregnancy or labor, the mother should see a doctor at once. The midwife can help to prevent serious results by getting the mother to a doctor without delay.

Explain that any of these symptoms means that there is poison in the mother's body which may injure or kill her or the baby, or both; that at the end the mother may have convulsions (fits) and may die. Take time to make it clear to the midwife that death from toxemia is almost always preventable and that every mother who has any of the symptoms of toxemia needs a complete examination by a doctor at once and treatment under his supervision. The symptoms often clear up with very simple treatment; without treatment they usually grow worse.

**Bleeding—Spotting.**—Explain the seriousness of bleeding during pregnancy. Any bleeding from the vagina at any time during pregnancy, no matter how slight, must always be reported to a physician. It may indicate an abortion, extrauterine pregnancy, placenta previa, premature separation of the placenta, or an obstructing growth. (These terms will be explained.)

If the bleeding comes **early** in pregnancy it suggests—

- A.* Abortion.
- B.* Extrauterine pregnancy—in which the fetus, or unborn baby, is outside the uterus, or womb.

In extrauterine pregnancy the irregular vaginal bleeding is sometimes very slight. It is particularly important that the mother have a skilled doctor at this time to find out the cause of the bleeding and to prescribe the care she should have. This slight bleeding may be followed by severe abdominal pain and the faintness and thirst that indicate internal bleeding.

When there is any bleeding, abdominal pain, or faintness the mother should be put quietly to bed and kept flat on her back until the doctor arrives. This timely care may prevent severe hemorrhage or abortion.

An abortion is always serious. Severe complications—spoken of by the mothers themselves as “body trouble”—frequently are caused by or follow abortions. Midwives in good standing do not attend such cases but use their influence to get the patient under medical care at once. If



a mother has had an abortion before she calls the midwife, the midwife can help her most by urging her to call a doctor and by keeping her quiet in bed until the doctor comes. With the right treatment he may be able to prevent or lessen the bad effects of an abortion.

Bleeding in **late** pregnancy suggests—

- A. Placenta previa, in which the placenta, or afterbirth, is over the mouth of the womb.
- B. Premature separation of the placenta, in which the afterbirth has torn loose before the birth of the baby.

**Bleeding in the last 3 months of pregnancy**, if accompanied by sharp abdominal pain, may mean that the afterbirth is loosening from the womb and unless something is done to help the mother at once she may bleed to death. **Painless bleeding** may indicate that the afterbirth is at the mouth of the womb, and the bleeding is caused by the tearing of the blood vessels as the mouth of the womb begins to open.

Any bleeding that occurs during pregnancy or early labor should be considered an alarming symptom. The doctor should be called at once.

**Tuberculosis.**—Tell the midwife about tuberculosis (lung trouble) just as you have told her about toxemia. The symptoms and signs that mean danger are—

- A. Nagging cough—a cough that hangs on.
- B. Pain in the chest that is worse when the mother takes a long deep breath.
- C. Spitting up blood.
- D. Loss of weight—going into a decline.
- E. Loss of appetite—not being hungry when it is eating time.
- F. Fatigue—being more tired than usual when there is nothing to be tired about.
- G. Fever.

Tuberculosis is a real sickness and it is serious, but if treated early it can often be cured. A person may get tuberculosis by kissing someone who has it, by eating from his plate, drinking from his cup, eating with his spoon. Or he may catch it by getting on his hands, face, or clothes the drops of spit that the sick person spreads around when he coughs or sneezes or when he touches things without washing his hands first. A mother is likely to get tuberculosis in one of these ways if she lives a long while with a person who has it. If the person who has it is careless, the mother is almost sure to catch it. She is then very likely to give it to the baby. A mother with tuberculosis should never nurse nor handle her baby.

The midwife should be taught how to explain to the mother that “germs” which cause disease or infection can be transferred (carried) from

one person to another—some of them from one part of the body to another part. Not all diseases are caused by germs. And transferred disease germs do not **always** cause disease, but **the chances are they will** when they are transferred to the moist, warm inner surfaces of our bodies or into scratches, cuts, and wounds. That is why everyone should know how to keep from transferring germs. Fingers, clothes, bedclothes, towels, washcloths, dishes, and so forth, that have touched an inflamed spot or that have been soiled by a discharge in which the disease germs live may be the means of transferring the germs to anyone touching these things unless the germs have first been killed by sterilizing, boiling, sunning, or pressing with a hot iron. Disease germs grow best in moist, warm, dark places away from sunshine, light, and air. Sunshine and soap and water, by means of which we keep our houses, our clothes, and our bodies clean, help to protect us from disease germs and keep us from transferring them to others.

Pregnancy makes tuberculosis more dangerous, and the pregnant woman who shows signs of tuberculosis needs constant care from a doctor. Such a mother may seem to be better during pregnancy; she may gain weight and feel well and then labor may be too much for her. Sometimes she cannot get out of bed after the baby's birth and may die shortly after the baby is born. The baby may be infected by the mother.

Explain how hospital care may prevent such a tragedy. Tell the midwives about a nearby tuberculosis hospital and emphasize that early and adequate care prevents and cures tuberculosis.

**Heart disease.**—Tell the midwives about the symptoms of heart disease. Some of the following symptoms will appear if the heart is not working properly:

- A. Shortness of breath and cold sweat on exertion.
- B. Blue fingernails.
- C. Gray, ashen complexion.
- D. Swelling of the ankles.
- E. Pain in the region of the heart.
- F. Inability to breathe easily or to sleep comfortably without extra pillows.

When any one of these symptoms appears the midwife should report the fact to a doctor at once. Unless his advice is followed, the condition may prove fatal.

If a midwife attempts to deliver a mother who has heart disease, the mother may become exhausted during labor and die before medical help can be secured.

**Gonorrhea.**—Explain to the midwives that this disease (“clap”) is an inflammation in the birth canal caused by a certain germ. The symptoms are—

- A. A more or less constant yellow vaginal discharge which stains the clothing from time to time.
- B. Swelling and soreness of the vulva (lips of the birth canal).
- C. Burning sensation when urine is passed.

If one of these symptoms appears, the midwife should notify the doctor at once and help the mother to make a practical plan for caring for herself, her clothes, her bedclothes, and so forth.

The midwife should be made to understand that the symptoms described are not always caused by gonorrhea germs; but whatever the cause, the inflammation must be treated by a doctor. If the mother does not have the proper treatment, the germs may spread, she may have “body trouble” after the baby is born and be sick for years, and the baby may become blind from having had his eyes infected with these germs while he was being born.

The careful midwife will not continue to care for the mother in whom these symptoms appear until the doctor who is treating her says it is safe.

**Syphilis.**—Discuss with the midwives the importance of learning early whether or not the mother has syphilis—“bad blood,” “the bad disease,” “the bad disorder.” In some parts of the South one of every three mothers has this dangerous disease. Many of them do not know they have syphilis, for the early symptoms cause little discomfort and soon disappear. But the disease persists and attacks their unborn babies, killing or injuring them, and later causes more sickness and suffering for the mothers, too.

All this can be prevented, for syphilis can be discovered by a blood test, and the mother can be given treatments that will protect her baby from infection and save her from the sickness and suffering. The blood test is part of that important medical examination which every mother should have early in pregnancy every time she is pregnant. And the earlier in her pregnancy she has this blood test the better, because a longer period of treatment during pregnancy means a better chance of protecting the baby of a mother with syphilis.

Be sure that each midwife knows how the treatment can be secured in her community from private physicians or clinics or through the department of health or of welfare. She should know, too, that the results of the treatment are good but come slowly, and that treatment must be continued for a long period, in many instances for months or even years.

The intelligent midwife will encourage the mother with syphilis to take **all** the treatment the doctor prescribes, after, as well as before, the baby is born and to follow his advice in every detail. She will not deliver a mother who she knows has syphilis unless the doctor who is treating the mother says she can safely do so (fig. 24, *a* and *b*).



Fig. 24a.—OUTCOME OF PREGNANCY IN UNTREATED SYPHILIS.

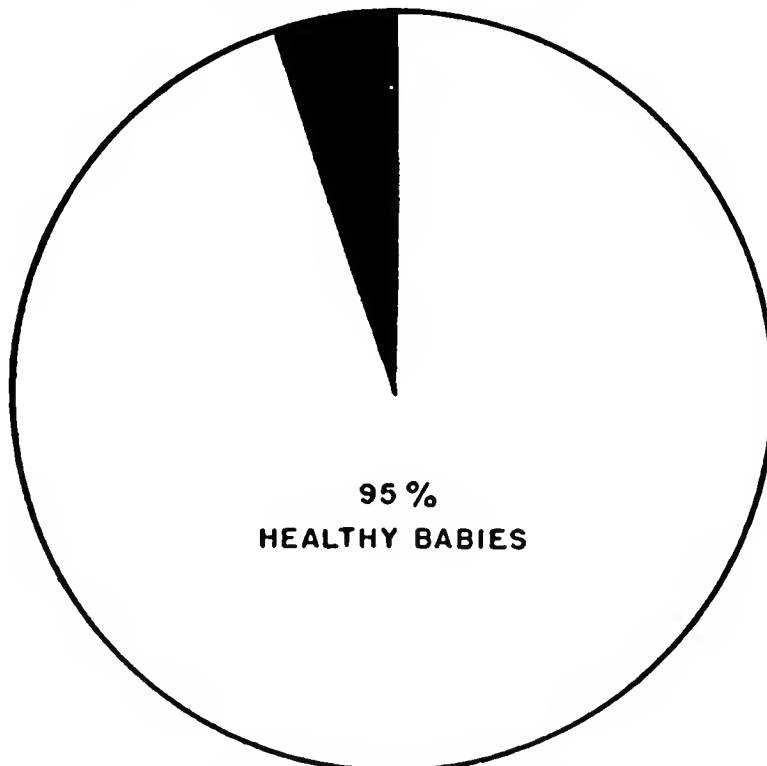

Fig. 24b.—OUTCOME OF PREGNANCY—SYPHILITIC PREGNANT WOMEN RECEIVING TREATMENT FOR 5 MONTHS OR MORE DURING PREGNANCY.

The mother who, either before or since she became pregnant, has had some treatment for syphilis but not enough to control the disease may, like the mother who has undiscovered syphilis, infect her unborn baby. The midwife who cares for the mother may also become infected and may transfer the disease to others if the mother has an abortion, a dead baby, or a live premature or full-term baby with the following symptoms:

- A. Rash on the baby's skin; peeling of the skin on the soles of the feet and palms of the hands.
- B. Sore mouth, discharging nose—snuffles.
- C. Little splits or cracks about the anus (the back passage) and sore buttocks.
- D. Bleeding from the nose, mouth, or rectum or in the skin.

The midwife who is called when a mother has an abortion or who delivers a dead baby or a live one with one of these symptoms should report to a doctor at once and do exactly as he advises. The mother needs more treatment. If the baby lives, he should have adequate treatment for syphilis according to the present standards.

Discuss with the midwives the **signs and symptoms of syphilis that may appear in the mother** during pregnancy or be discovered after she is in labor:

- A. Sores, warts, or hard scar on the vulva.
- B. Rash on the skin.
- C. Sore throat, sore mouth.
- D. Swollen, tender glands—sore lumps—pain in the bones.
- E. Falling out of hair and eyebrows.

When the mother has syphilis she may infect not only her unborn baby but other children in the family and people in the community. The midwife attending a mother who has syphilis may become infected and spread this disease to other mothers or even to her own family. When one of these symptoms is discovered the midwife should report it to a doctor at once. If the trouble is found to be syphilis, the midwife should explain to the mother that she cannot continue to care for her because special medical treatment is needed.

Emphasize that it is the syphilis which is not discovered in time or for some other reason is inadequately treated that injures or kills unborn babies and is transferred to other people. Even though it takes a long time, syphilis can be controlled, unborn babies can be protected from it, and those who have the disease can learn how to keep from giving it to anyone else.

Sores anywhere on the body that do not heal may seriously infect the mother at the time of delivery. Such sores should be shown to the doctor so that they may be adequately treated before the time of delivery.

**General symptoms.**—The symptoms already talked about point toward definite diseases but sometimes pregnant women have symptoms which may suggest any one of a number of diseases.

Fever, chills, diarrhea, sores which do not heal readily are such symptoms. They should be reported to a doctor because in some cases they may mean that a serious condition is developing.

### Calling the Midwife

Discuss with the midwives how, when a midwife registers a mother, she can tell her, without scaring her, about the importance of calling her midwife at once if she is nervous or worried about anything and if she has any unusual symptoms. Emphasize the midwife's duty to see the mother as soon as she can after she is called and to report any serious symptom to a doctor at once.

See that each midwife knows what she can do to get medical care for the mother if there is no private doctor available. Make it easy for her to get in touch with a local or county nurse whenever she needs help or advice and cannot get in touch with a doctor. The nurse may know of a doctor who is unknown to the midwife.

### SUMMARY

Make it clear to the midwives how much more they can do for mothers today than did the old-fashioned midwife. Years ago midwives did not know anything about watching during pregnancy for the danger signals; their care of mothers began with labor. Today the intelligent midwife will make every possible effort to secure for the mother the protection afforded by a complete physical examination by a good doctor and to help her to follow his advice. Even after the complete examination by the doctor, the midwife, like the public-health nurse, needs to be on the lookout for danger signals constantly all during pregnancy, so that she can call a doctor if all is not going well.

Symptoms that should be reported to a doctor are—

- A. Spots before the eyes.
- B. Inability to see well, haziness before the eyes, blurring of vision, or dizziness.
- C. Severe or persistent headache.
- D. Swelling of the ankles, feet, hands, eyelids, or face.

- E.* Cramping pains around the pit of the stomach.
- F.* Scant urine (passing little water, which may have a somewhat dark color) or inability to void (pass water).
- G.* Vomiting.
- H.* Great gain in weight.
- I.* Muscular twitching.
- J.* Any bleeding or spotting, no matter how slight.
- K.* Sharp abdominal pain.
- L.* Nagging cough—a cough that hangs on.
- M.* Pain in the chest that is worse when the mother takes a long breath.
- N.* Spitting up blood.
- O.* Loss of weight—going into a decline.
- P.* Loss of appetite—not being hungry when it is eating time.
- Q.* Fatigue—being more tired than usual when there is nothing to be tired about.
- R.* Fever.
- S.* Shortness of breath and cold sweat on exertion.
- T.* Blue fingernails.
- U.* Gray, ashen complexion.
- V.* Pain in the region of the heart.
- W.* Inability to breathe easily or sleep comfortably without extra pillows.
- X.* Any vaginal discharge.
- Y.* Swelling or soreness of the vulva.
- Z.* Burning or smarting when passing urine.
- AA.* Sores, warts, or hard scar on the vulva.
- BB.* Rash on the skin.
- CC.* Sore throat, sore mouth.
- DD.* Swollen tender glands—sore lumps—pain in the bones.
- EE.* Fever, headache, or chills.
- FF.* Falling out of hair and eyebrows.
- GG.* Sores that do not heal.

## Inspection of the Midwife's Standard Equipment

### A DEMONSTRATION AND PRACTICE PERIOD

#### Purpose

To teach the midwife about the contents and orderly arrangement of the standard bag.

To give her an appreciation of what is observed in the inspection of a bag.

#### Equipment

A bag containing the midwife's standard equipment. (See p. 6.)

Table with a clean paper cover.

Hand basin, bucket of water, dipper, soap in a dish, paper towels.

#### Procedure

Place on the table your closed bag, which is in perfect condition and perfectly packed. Speak of the appearance of the outside of the bag—clean, water repellent, tightly closed, all seams tight, fastening and handles good so that the bag will protect the contents from dirt and weather and will not break when in use.

Wash your hands. Open the bag. Show how it will stay open. Call attention to the **clean** lining, show that it fits, that it is of the right size to protect the edges of the bag, that the tapes are strong enough and long enough to tie securely.

Lift out the packages one at a time. Speak of the condition of the bag—clean and in repair. Show how the size and shape are correct for holding and protecting its contents; nothing sticks out or falls out when a package is taken from the bag. Tell why each package is packed in the bag as it is.

Open each package in turn as it is lifted out. Comment on the arrangement or folding of the contents. Show how the size is correct. Note that washable things are freshly laundered. Test the other things to see that they are in good condition.

Open the sterilizing basin. Show the dry brush and stick and explain why they and the basin must be dry before the basin is covered.



Examine the sterile packages. Explain why they must be tight and correctly folded. Break the seal and open one to show the arrangement of the contents. Examine the contents and explain why they are made as they are. Be sure to point out that this opened package is no longer sterile. It must be sealed and sterilized again before it can be used at a delivery

Examine the scissors to show that the screw is tight and they are sharp and clean. Tell why they have blunt points and must be tight.

Emphasize the importance of the record forms that the midwife must keep. Show a sample of each form properly filled in and explain each item.

Explain about the inspection of the midwife's bag and how much it shows about her and her way of working.

Repack the bag, explaining again about the arrangement.

Give each midwife an opportunity to take part in packing and unpacking the bag and in explaining its arrangement and contents.

Be sure that each midwife knows where she can get or how she can make each article in the standard equipment, and ask her to bring her bag with her to the last session when all bags will be inspected.

## The Prenatal Period

### TEN-MINUTE REVIEW

What is a midwife?

Where does she get her legal right to practice?

What type of mother does she care for?

How would a midwife figure the date of delivery?

What should a midwife do if called on an abortion case?

Why is a complete examination by a doctor and following his advice important to the expectant mother?

Why is a complete medical examination of the expectant mother a special protection to the midwife's reputation?

What danger signals appearing during pregnancy need immediate attention from a physician?

Why should a woman's blood be tested early in pregnancy?

What should be done if the blood test shows that a mother has syphilis?

Who gives treatment for syphilis?

What responsibility has the midwife for a patient who has syphilis?

Of what importance is this to the baby and to the midwife?

### Everyday Living

Discuss with the midwife, so that her influence with the mothers can be used to good purpose, the simple, homely, day-to-day needs of all pregnant women. The 40 weeks, or 280 days, of pregnancy while the baby is living and growing in his mother's uterus (womb) are spoken of as the prenatal period of his life. *Pre* means before and *natal* means birth; so prenatal means before birth.

This prenatal period of the baby's life is a time of preparation for the mother. She should live so as to gain all the strength she can for the hard work of carrying, delivering, and nursing the baby. Everything that is good for her will help the baby that is within her body to grow strong.

**Food.**—Tell the midwife what to teach the mothers about the food they should have. Every mother should know the importance of her diet

during pregnancy. Before the baby is born he gets all his nourishment from his mother. It is her food that is used to make his body. During at least the first 6 months after his birth, too, it is best that his mother's breast milk should supply most of his nourishment.

By eating properly the mother can help to prepare for the delivery and improve the chances of being able to nurse her baby. Her strength at delivery is largely dependent on the food that she has eaten all during pregnancy. Every muscle, bone, and blood vessel, the blood, and the nervous system are improved by good food. Tell the midwife why the mother should eat simple, adequate meals and not eat anything that she knows may give her indigestion. Too much food at one meal is not good. All food should be eaten slowly and chewed well.

Explain the value of including the following foods in the diet during pregnancy and the nursing period. This kind of adequate diet is also good for each member of the family.

**Milk.**—Milk is good to drink or to use in soups, cocoa, vegetables, and puddings. One quart of milk a day will provide calcium (lime), which is necessary for building bones and teeth. Evaporated milk is easier to keep in warm weather and usually costs less than fresh milk. When mixed with an equal amount of water, evaporated milk has the same food value that the same amount of fresh milk has. Buttermilk or skim milk (fresh or dried) may be used as part of the required amount of milk.

**Other liquids.**—Everyone who is well needs at least eight glasses of liquids each day. By liquids are meant milk, water, lemonade, orangeade, tea, and coffee. Moderate use of tea or coffee is not harmful to most women.

**Vegetables** are rich in minerals and important vitamins that help to build bones, teeth, muscles, and good red blood. At least two vegetables in addition to potatoes should be eaten every day.

Tender vegetables are good to eat raw. Other vegetables should be cooked only until they are tender; overcooking destroys part of their value. The least possible amount of water should be used, and all juice that remains when the vegetables are done should be used in making soup or gravy. This "pot liquor" is full of valuable mineral salts and should not be thrown away.

**Fruit.**—Two fruits should be eaten daily if possible. Tomatoes (raw, cooked, or canned) may be eaten in place of fruit.

**Cereal.**—A serving of whole-grain (dark) cereal or whole-grain bread should be part of every day's food. Water-ground corn meal is a whole-grain cereal.

**Egg and meat.**—An egg and one serving of meat, fish, or poultry should be eaten daily if possible. Cheese and dried beans or peas may take the place of meat now and then.

**Other foods.**—Once the important foods already listed have been included in the diet, other simple, easily digested foods can be added to satisfy the appetite and give the mother energy to do her work.

**Sleep.**—At least 8 hours of every night should be spent asleep in bed with the windows open if the pregnant mother is to get sufficient rest.

**Rest and exercise.**—Some regular housework is good exercise, but every pregnant mother needs to lie down several times a day if only for 5 minutes at a time. At least an hour's rest during each day is necessary. A walk or some rest out of doors each day is excellent; fresh air is good for the mother and the baby. If the mother cannot spend any time out of doors, she should keep the windows open while she does her indoor work. Warn her about the danger of unusual or heavy work. It might hurt the baby.

**Bathing.**—If possible, an expectant mother should have a complete bath with warm water and soap every day. After the seventh month she should not get into a tub but should take a sponge or shower bath instead.

**Clothing.**—The expectant mother should wear loose, comfortable clothing hung from the shoulders. She should not wear garters around her legs nor any tight bands. She should not roll her stockings, for if they are rolled tight enough to hold them in place above or below the knee they will impede the circulation. A well-fitting maternity corset or abdominal binder may add to her comfort. A brassiere should be chosen that supports the breasts but does not bind them tightly. The breasts should be allowed plenty of room to develop. Shoes with low, broad heels are best.

**Elimination.**—If the pregnant mother is drinking enough fluid she should void from 1 to 2 quarts of urine—pass from 1 to 2 quarts of water—every day. Voiding too little urine, dark in color, is one of the danger signals of pregnancy. (See lesson I, p. 26.)

The bowels should move regularly. Constipation is usually caused by lack of exercise, incorrect diet, too little or too concentrated food, insufficient fluids, or irregular toilet habits.

To correct constipation the mother should drink one or two glasses of hot or cold water before breakfast; go to the toilet at the same time every day, preferably after breakfast; eat whole-grain (dark) bread, green vegetables, raw or cooked fruit, especially prunes and figs; and drink water between meals.

**Preparation for nursing.**—The ideal food for the baby is his mother's milk. It is the easiest and cheapest baby food to be had. Flies cannot spoil it and it will not sour. The mother's general health, her food, and her rest affect the quality and the quantity of her supply of milk for the baby.

**Supporting the breasts.**—Show the midwives how to teach the mother to support her breasts. Breasts should not be compressed by a tight binder nor allowed to sag of their own weight.

A well-fitted brassiere with broad straps over the shoulders will support the breasts correctly. This type of brassiere should be worn every day after the breasts begin to enlarge. The brassiere should be made of thin, porous material that washes easily and allows good ventilation. Brassieres should be washed every day. (Fig. 25.)

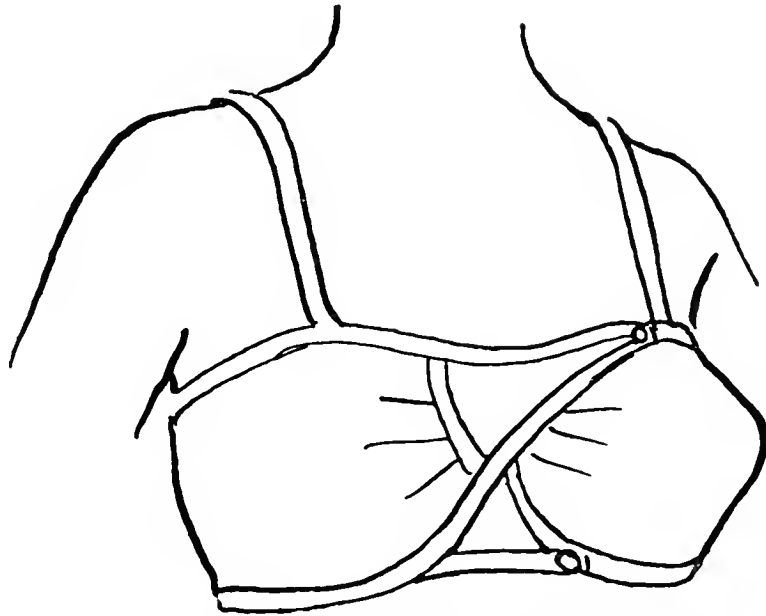

Fig. 25.—MODEL OF BRASSIERE SUPPORTING BREASTS.

**Care of the birth canal.**—Be sure that the midwife knows about telling the mother why she should not take a douche during pregnancy unless a doctor has said she needs one; why she should not permit any one except a doctor to examine her internally at any time during pregnancy or labor; why she should have no sexual intercourse after the seventh month of pregnancy until 6 weeks after delivery.

### Labor

Be sure the midwife knows that it is important to tell the mother how she will know when labor begins, why she must notify the midwife at once, and what she is to do while waiting for the midwife. If the midwife is notified at once, she can get there in time to make all the necessary preparations for the clean delivery technique that protects the mother and

baby from infection. The woman who has had several children and thinks she should wait to notify the midwife until pains become regular and close together runs an unnecessary risk for herself and her baby. The midwife should have a fair chance to prepare the mother, herself, and her equipment and to be on hand to conserve the mother's strength during labor.

Labor usually begins with pain that starts in the lower part of the back and works around to the abdomen or starts in the abdomen and works around to the back. During the pain the uterus becomes hard and contracted but softens or relaxes as the pain passes off. Labor pains recur at shortening intervals and last longer and become stronger.

A discharge of mucus slightly stained with blood is called the "show" and should also be considered a sign of beginning labor. The midwife should be called as soon as the show appears or pains begin.

After the midwife has been called, two large covered kettles of water should be put on the stove to boil, and one may be set aside to cool after it has boiled for 10 minutes. The mother's bed should be prepared for labor. (See lesson VI, p. 55.) The mother should take a warm sponge bath and comb her hair; and if it is long, she should fasten it in braids so that it cannot come undone. The mother's supplies should be set out where they are easy to reach. The baby's bed should be put out with a set of baby clothes, blankets, and receiving blanket in it, as well as a hot brick, iron, or water bottle to warm the bed and everything in it. The mother should then "take it easy" until the midwife arrives.

Sometimes the membranes may rupture—the bag of waters break—before the mother has felt any labor pains, though usually this happens after the mother has been in labor for some time. Whenever the membranes rupture the mother should go to bed, and, if she has not already done so, she should send for her midwife.

Be sure that the midwife understands that she should tell every mother she registers about going to bed and **calling a doctor at once if there is any bleeding**, because bleeding is a serious danger signal and not one moment should be lost in getting a doctor.

### Premature Labor

Explain to the midwife how she can tell the mother about premature labor—labor that begins any time after the mother has felt life and more than 2 weeks before the date the baby is expected. If the mother has any cramplike pain, she should go to bed and send for her midwife. If the midwife is "suspicious" that the mother is in labor she should notify a doctor immediately. Premature birth can often be prevented by keeping the mother quiet in bed and getting a doctor at once. The midwife must

not deliver such a mother because a premature delivery is not normal; the mother and baby need the best of medical care.

If the mother is not in labor but is having persistent abdominal pain, the midwife should notify the doctor so that he can find the cause of the pain and give the mother the care she needs.

### SUMMARY

The good midwife who knows the day-to-day needs of the pregnant mother will use her influence to encourage her to eat the food that is good for her—plenty of milk, vegetables, and fruit and small amounts of meat and cereals or breads every day; to drink the eight glasses of fluid a day; to get enough sleep, rest, and exercise; to be careful about her bathing, clothing, and elimination every day; to do all that she should to be ready to give birth to her baby and to nurse him.

The midwife will be very sure the mother knows when to call her and what to do when labor begins, when there is bleeding, or when the membranes rupture before the midwife arrives.

## Making the Supplies

### A DEMONSTRATION AND PRACTICE PERIOD

#### Purpose

To show the midwife about making the supplies that will serve well when the mother cannot buy everything she needs. When nothing else is available newspapers can be used to protect beds and to make pans and bags that will take the place of basins and buckets.

#### Equipment

A table; iron on the stove; iron holder; several pieces of fresh, clean wrapping paper; a generous supply of clean newspapers; grade-A and grade-B absorbent cotton; 24 pieces of unbleached muslin (46 inches long and 36 inches wide) and a bag of clean white rags of various sizes for making sanitary pads, lining for newspaper pans, wipes, and so forth; hand basin; bucket of water; dipper; soap in dish; and paper towels.

#### Procedure

Show the midwife how to make the various articles and explain their many uses. Wash your hands before beginning and explain why washing is necessary.

**Newspaper bag.**—Spread on the table before you two full-size double sheets of newspaper folded to the size of a newspaper page, one sheet inside the other with the edges even, so that there are four thicknesses of paper. Fold the two upper thicknesses in half lengthwise of the columns of printing (fig. 26, step 1). Turn the paper over, fold it in thirds crosswise of the columns of printing (step 2), and tuck E and F between A and B (step 3) to complete the bag. The pocket that is to be used as a bag is now on the under side, and therefore the paper should be turned over. C becomes the flap that slips under the edge of the tray, or it can help to reinforce the side so that the bag can be opened up wide and stand on a table. Explain that three of these newspaper bags will be needed (see p. 56).

**Newspaper pan.**—Lay newspapers opened wide at angles one with the other and roll in the edges (fig. 27, three views). Six thicknesses of paper will make a thin pan that can be used to catch soiled cotton, rags,



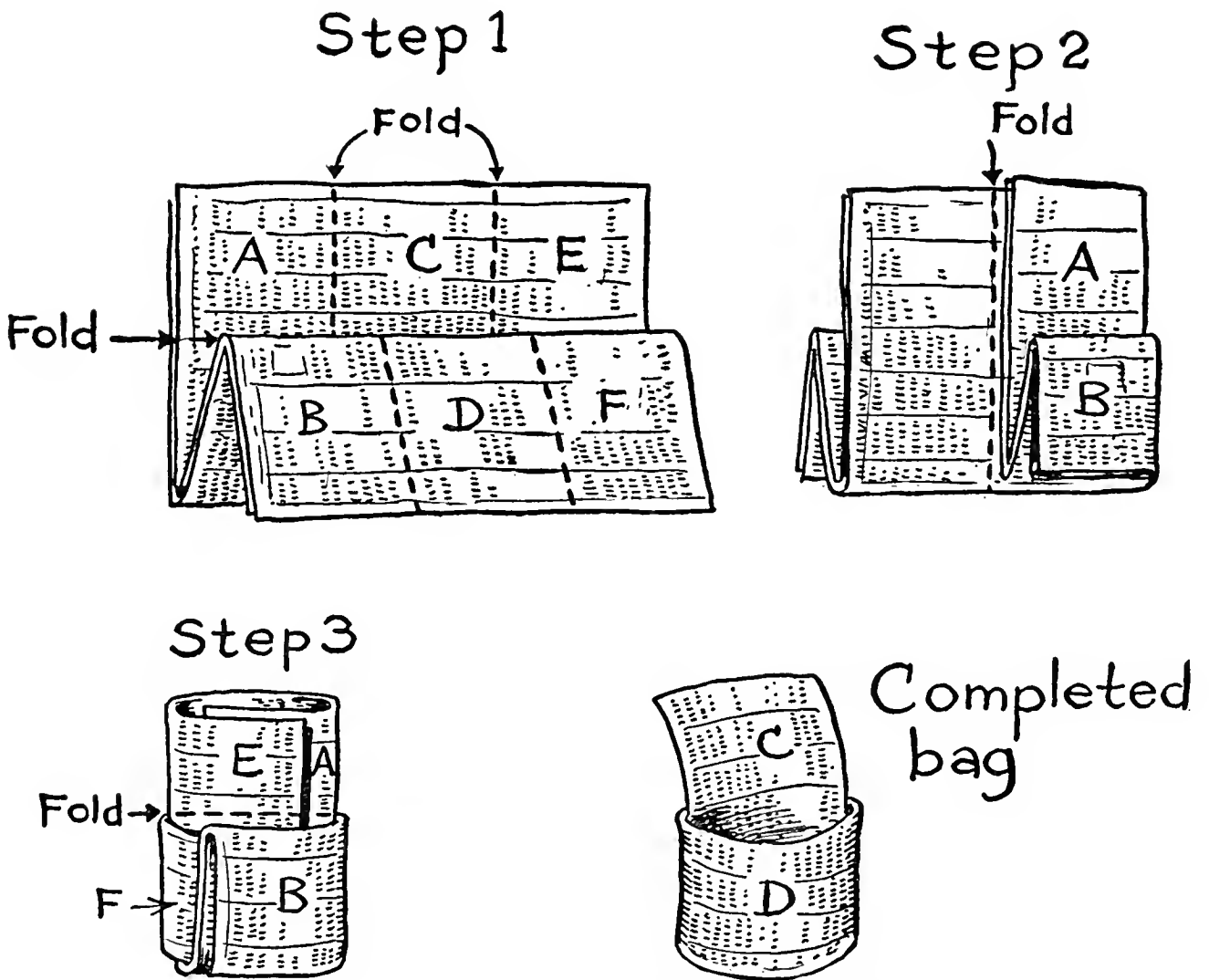

Fig. 26.—MAKING NEWSPAPER BAG. FOUR VIEWS.

and so forth. Explain that three of these thin newspaper pans will be needed.

A thick pan can be made of 16 to 20 thicknesses of newspaper. Explain that three of these thick newspaper pans will be needed. One of these thick newspaper pans should be lined with a clean rag (see pp. 56, 98).

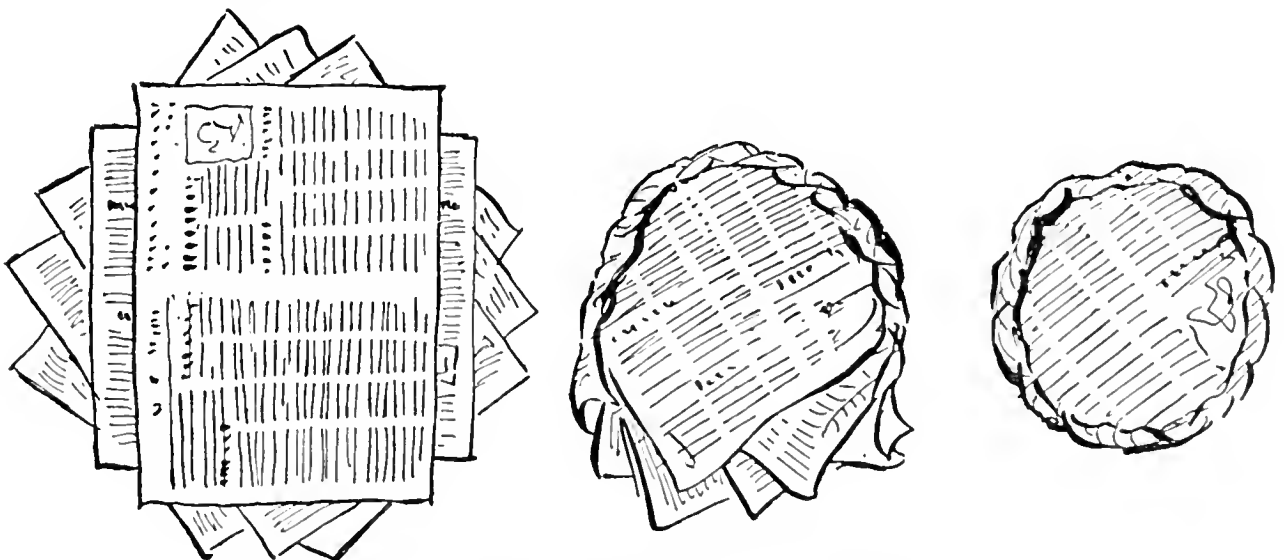

Fig. 27.—MAKING NEWSPAPER PAN. THREE VIEWS.

A thick newspaper pan can be used as a bedpan if it is not possible to get a regular bedpan or to improvise one from a bakepan and a smooth board covered with a newspaper and placed across one end of the pan. The three thick newspaper pans will be needed in addition to the bedpan.

**Newspaper pad.**—Spread on the table one of the large pieces of unbleached muslin. Explain that the midwife can teach the mother to use freshly laundered old white rags instead of the unbleached muslin you are using. On this lay one sheet of newspaper opened to full size to serve as a pattern for making the pad cover the right size. Fold the muslin over the edge of the newspaper on all four sides, remove the newspaper, and tack the corners of the muslin securely to make the pad cover. Explain that the mother should make six of these covers.

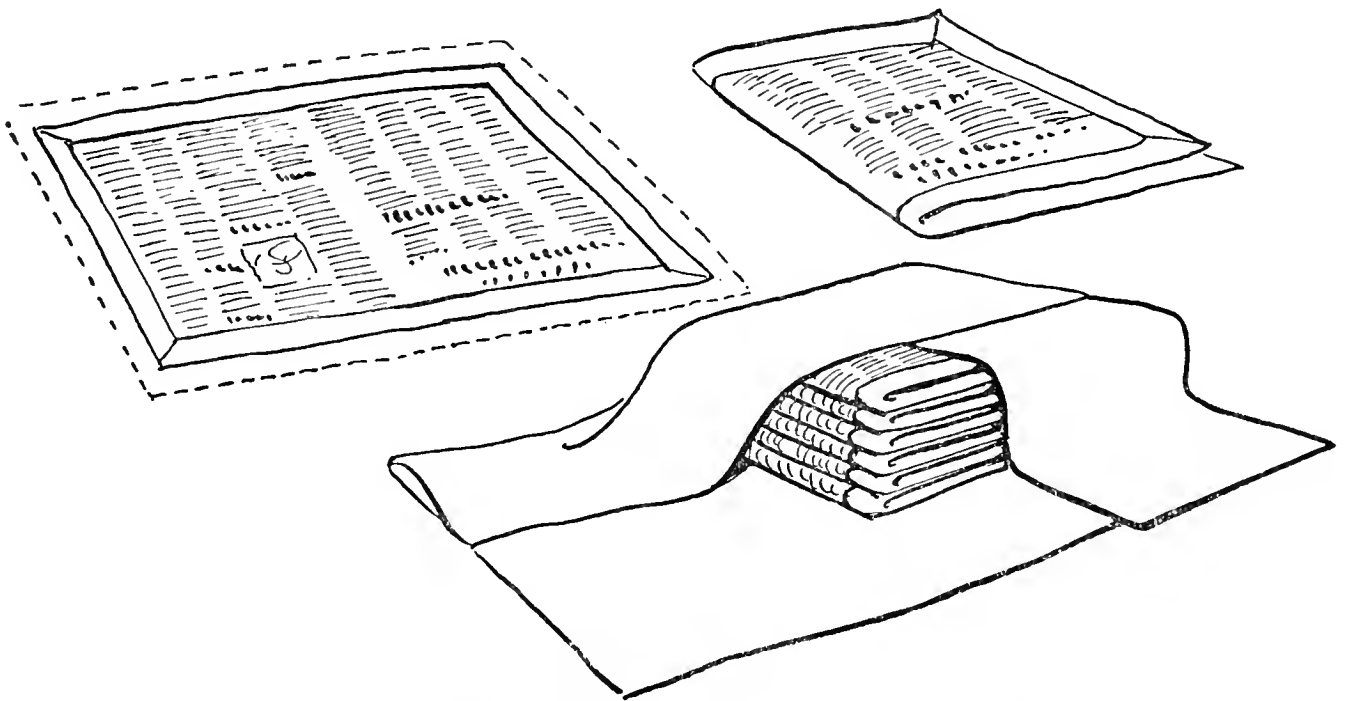

Fig. 28.—MAKING NEWSPAPER PADS. THREE VIEWS.

Open 12 sheets of newspaper wide and stack them with the edges even and insert them in the cover. Turn the cloth side up. Wash your hands. With a very hot iron, press the cloth from side to side until the whole surface has been ironed. Do not touch the cloth side with the hands after ironing it. Fold the pad with the cloth side in and explain that the mother's six pads, each one ironed and folded this same way, should be wrapped in paper or two thicknesses of newspaper and the package put away with the mother's supplies (fig. 28, three views).

At delivery or during the postpartum period, as the pads are used and become soiled, the newspapers can be taken out and burned and the muslin covers washed and boiled to use again.

**Sanitary pads.**—If sanitary pads can be bought, show the midwives how they should be kept covered and not handled before they are used.

Sanitary pads can be made of freshly laundered old muslin about 18 to 24 inches square. Fold, and iron each fold as shown in fig. 29. These home-made sanitary pads should be wrapped individually in clean wrap-

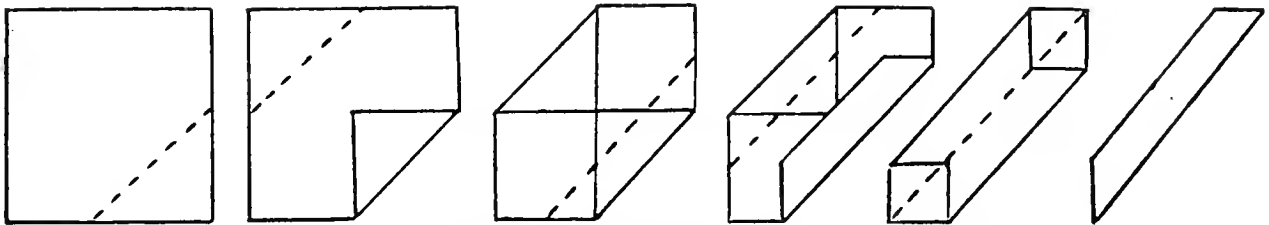

Fig. 29.—MAKING SANITARY PADS. SIX VIEWS.

ping paper and put away in a convenient drawer until it is time to sterilize them. (For directions for sterilizing the pads see p. 21.)

**Cotton balls.**—Demonstrate how to make large and small cotton balls for the baby's tray, using the grade-A absorbent cotton, and explain their use (fig. 30, three views). Explain that when the midwife prepares

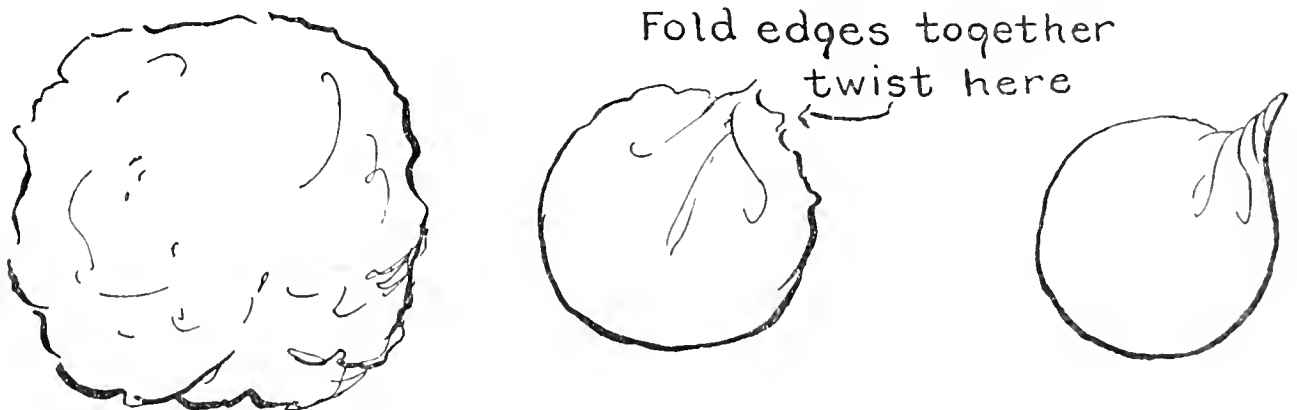

Fig. 30.—MAKING COTTON BALLS. THREE VIEWS.

the baby's tray she should make enough large balls to fill one jar and enough small balls to fill another jar. (See pp. 50, 53.)

**Cotton swabs.**—Demonstrate also how to make cotton swabs of the grade-B cotton and explain that rag wipes can be used if the mother cannot get cotton for making these swabs.

---

Have the midwives practice making each item, first in groups, then under individual supervision until they can make everything correctly.

## The Mother's Preparation for Delivery

### TEN-MINUTE REVIEW

- What type of mother does a midwife care for? How can a midwife best serve an ailing mother?
- Why is a complete physical examination by a doctor important to the expectant mother?
- Name some of the danger signals of pregnancy.
- What do we mean by the prenatal period?
- What should a pregnant woman who is well eat, and why?
- How much liquid should she drink?
- How many hours should she sleep? Why is rest important?
- What kind of exercise should she take?
- What kind of bath should she take the month the baby is expected?
- What kind of clothing should she wear?
- What should be done for constipation?
- What are the signs of beginning labor?
- When should the mother call the midwife?
- What should a mother do when labor begins?

### When To Prepare

Explain why it is important to have things ready early. As we do not know what brings about the onset of labor and cannot predict the exact day on which it will occur, it is important that everything be prepared well in advance of the day the baby is expected.

The expectant mother should begin her preparations early in pregnancy so that she will not be forced to hurry at the end. Rush and hurry are very tiring. Explain that everything should be in readiness by the beginning of the eighth month—8 weeks before the baby is expected.

Go over each item on the list of supplies, explaining possible substitutes and the use which will be made of each article. The midwife should help the mother with a plan for getting the supplies early. The mother should first get two boxes or clean out two bureau drawers, one for her supplies and one for the baby's, in which to put the things when she prepares them so that they will be clean and in order.

### Supplies for the Mother (fig. 31)

These she **must** have:

- A. Four basins or pans (two of them the same size).
- B. Two large covered kettles for boiling water (teakettle and large stew pan or boiler with cover).

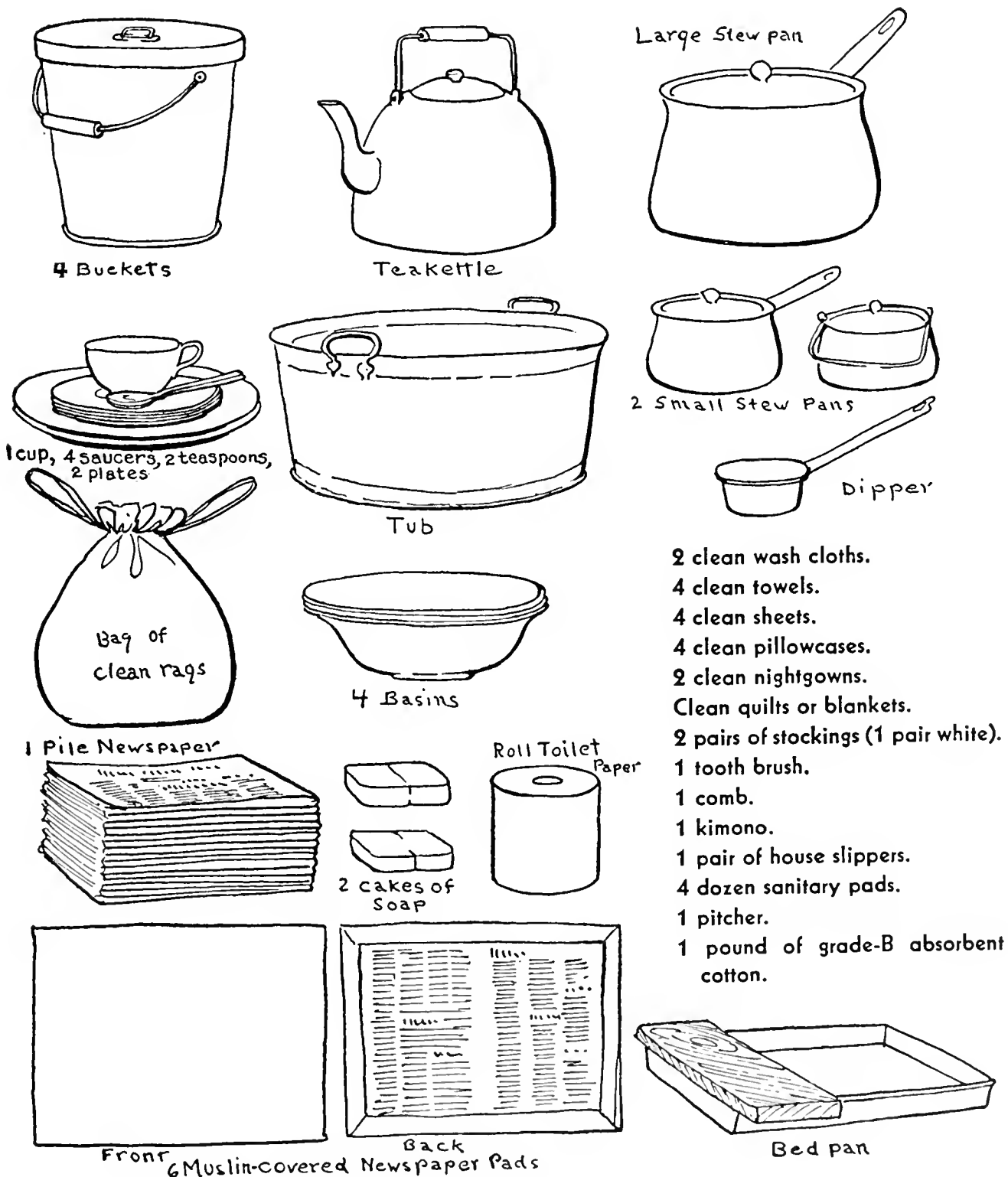

Fig. 31.—SUPPLIES FOR DELIVERY.

- C. One long-handled dipper.
- D. Two stew pans with lids such as are used for cooking vegetables.
- E. One quart pitcher or mason jar.
- F. One cup, four saucers, two teaspoons, and two plates.

- G. One toilet bucket with a cover and three uncovered buckets (one for clean water and two for dirty water).
- H. Laundry tub ready—empty and clean.
- I. Two cakes of white soap. Saucers can be used as soap dishes.
- J. Two clean washcloths.
- K. Four clean towels.
- L. Four clean sheets.
- M. Four clean pillowcases.
- N. Clean quilts or blankets.
- O. Two clean nightgowns.
- P. One kimono or smock.
- Q. Two pairs of clean stockings (white preferred).
- R. One pair of house slippers.
- S. One toothbrush.
- T. One comb.
- U. One pair of ordinary household scissors.
- V. Six newspaper pads. (See lesson IV, p. 44.)
- W. Four dozen machine-made sanitary pads bought packed in boxes, or 12 home-made pads of clean old muslin. (See lesson IV, p. 45.)
- X. One bag of clean white rags of various sizes for making wipes, sanitary pads, covers for the newspaper pads, and so forth.
- Y. A large bundle of newspapers, about 200 sheets.

These she **should** have:

- A. One roll of toilet paper (kept wrapped).
- B. One pound of grade-B absorbent cotton to use instead of rags for making wipes.
- C. One bedpan (tin, zinc, or enamel) or a bakepan and a smooth board covered with a newspaper and placed across one end of the pan for a bedpan.

The midwife should make it her business to know that every mother whom she registers for delivery has her supplies ready in good time. She can help the mother who cannot buy things to make the best use of those she has in the house.

### Supplies for the Baby (fig. 32)

Explain to the midwife all about the supplies which the mother should have to make it easier to give good care to the baby.

These she **must** have:

- A. Three shirts, size 2, open down the front.
- B. Three bands—made of outing flannel. Half a yard torn into three equal strips will make three bands 6 inches wide and 27 inches long.
- C. Two dozen diapers 27 inches square.
- D. Three baby blankets 36 inches square.

- E. Two flannelette squares 36 inches on each side.
- F. Two small, soft washcloths.
- G. Two towels—old, soft, clean ones are best.
- H. One bed for the baby—a paper carton, a wooden box, a basket, or a home-made crib. It should be at least 30 inches long, 18 inches wide, and 12 inches deep.

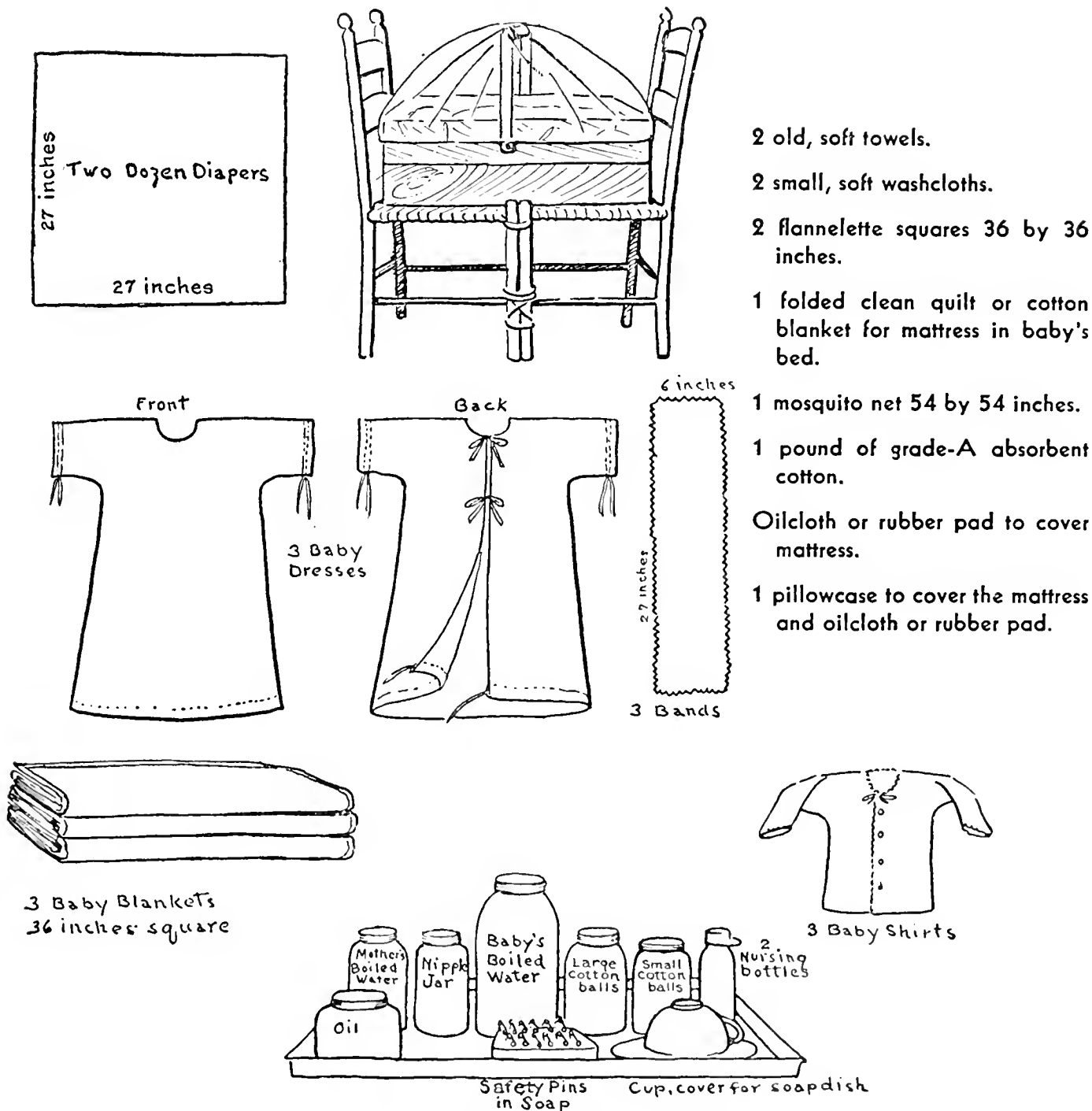

- 2 old, soft towels.
- 2 small, soft washcloths.
- 2 flannelette squares 36 by 36 inches.
- 1 folded clean quilt or cotton blanket for mattress in baby's bed.
- 1 mosquito net 54 by 54 inches.
- 1 pound of grade-A absorbent cotton.
- Oilcloth or rubber pad to cover mattress.
- 1 pillowcase to cover the mattress and oilcloth or rubber pad.

Fig. 32.—SUPPLIES FOR THE BABY.

- I. One crib mattress. A hair pillow is best, but a folded, clean cotton blanket or quilt makes a good substitute.
- J. One rubber pad or piece of oilcloth to cover the mattress.
- K. One pillowcase for covering the mattress and the mattress pad.
- L. One mosquito net to cover the baby's bed. A piece of mosquito netting 54 inches square, rounded at the corners, hemmed all around

the edge with elastic run in the hem. This size will fit the ordinary baby bed of the size given above.

*M.* Baby tray 12 inches by 15 inches or larger.

*N.* Five covered glass jars for—

1. Oil.
2. Mother's boiled water.
3. Nipples and rubber bottle caps.
4. Large cotton balls.
5. Small cotton balls.

*O.* One pint bottle or jar with top, for baby's boiled water.

*P.* Two nursing bottles—4-ounce size.

*Q.* Four nipples.

*R.* Two rubber caps for nursing bottles.

*S.* One dozen large safety pins.

*T.* One dozen small safety pins.

*U.* Two cakes of white unscented soap.

*V.* One pint of mineral or cottonseed oil.

*W.* One soap dish. A saucer with a cup turned upside down over the soap will serve.

*X.* One pound of grade-A absorbent cotton.

These she **should** have:

Three dresses—made with kimono sleeves and open all the way down the back. (But blankets are more important.)

### **Choosing the Room for the Delivery**

Teach the midwife what to look for in advising the mother which room to use for the confinement room. If a choice of rooms is possible, choose the room that best meets the requirements of cleanliness, comfort, and convenience. These are things to consider in the selection of the room:

- A.* Size. It should be large enough to allow for free working space.
- B.* Nearness to bathroom or kitchen to make easier the preparation for delivery and care in the postpartum period.
- C.* Ventilation. It should be easily aired without draft.
- D.* Sunshine. It should be cheerful for convalescence.
- E.* Quietness and privacy. It is helpful if the room can be shut off from the rest of the house
- F.* Good light, day and night.

### **Advance Preparation of the Room**

Teach the midwife how to give the mother detailed directions about preparing the room for confinement and the family's responsibility for getting this done.



About 1 month before the expected date of confinement all the furniture, ornaments, and clothing which are not needed in that room should be put somewhere else in the house in order to give more space for quick action and to do away with the danger of spoiling things. Then the husband or other strong person should help to give the room a thorough cleaning. Go over with the midwife the directions for cleaning a room thoroughly. The mother should not do any of the lifting or heavy work.

**To "house clean" a room.**—Clean the dresser drawers, dust and wash all the furniture, and move each piece except the bed into an adjoining room. Strip the bed and put the soiled linen to soak and the clean comfortables or blankets to air in the sun.

Examine the mattress carefully for vermin, looking well into the seams and folds; brush it thoroughly around the buttons and bindings, sweeping from the center toward the edge. Turn the mattress over and repeat the process. Stand the mattress on its side at the head of the bed on newspapers. Put a clean newspaper on the spring or slats, and brush the pillows on both sides.

Carry the mattress and pillows into the open air, hang them on a clothesline or fence or lay them on clean chairs or on the grass, and leave them exposed to the sunshine, if possible, all day. Bring them in before night to keep them from getting damp from dew.

If the weather or the housing situation prevents taking the bedding into the open, air it all as long as possible in front of an open window in another room.

Take down all the curtains and have them washed or cleaned. Remove any rugs or carpets, have them cleaned if possible, or sweep both sides, shake, beat, and air them. If they must be swept in the house, put wet paper on them first to keep the dust from rising.

If there is much dust under the rugs, sprinkle the floor lightly to lay the dust before sweeping.

Examine the bed for vermin. Dust the springs, wash the slats and bed frame.

Wash the windows, inside and outside. Wash the woodwork and door knobs, giving particular attention to any accumulation of dust in cracks or ledges of the moldings.

After everything else is thoroughly cleaned, scrub the floor. When it is dry, lay the rugs and rearrange the furniture as it will be most convenient for the delivery.

**To rearrange the room after house cleaning.**—Make sure that the bed and mattress are free from vermin and that the bed is put to-

gether securely. Place the bed so that it is out from the wall with both sides easily accessible and the right side toward the center of the room. The best light should fall across the foot of the bed.

If the spring or mattress has sagged and there is a hollow in the bed, a table leaf or a strong, wide board should be used to reinforce it at the time of delivery (fig. 33 and pp. 4, 55).

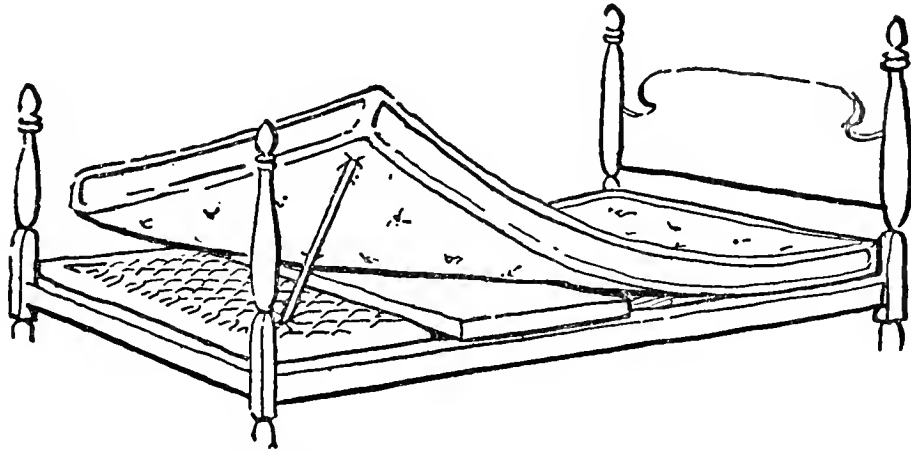

Fig. 33.—BOARD PLACED UNDER MATTRESS IN PREPARATION FOR DELIVERY.

There should be a good bright light that can be used day or night. Such a light should be adjustable and portable.

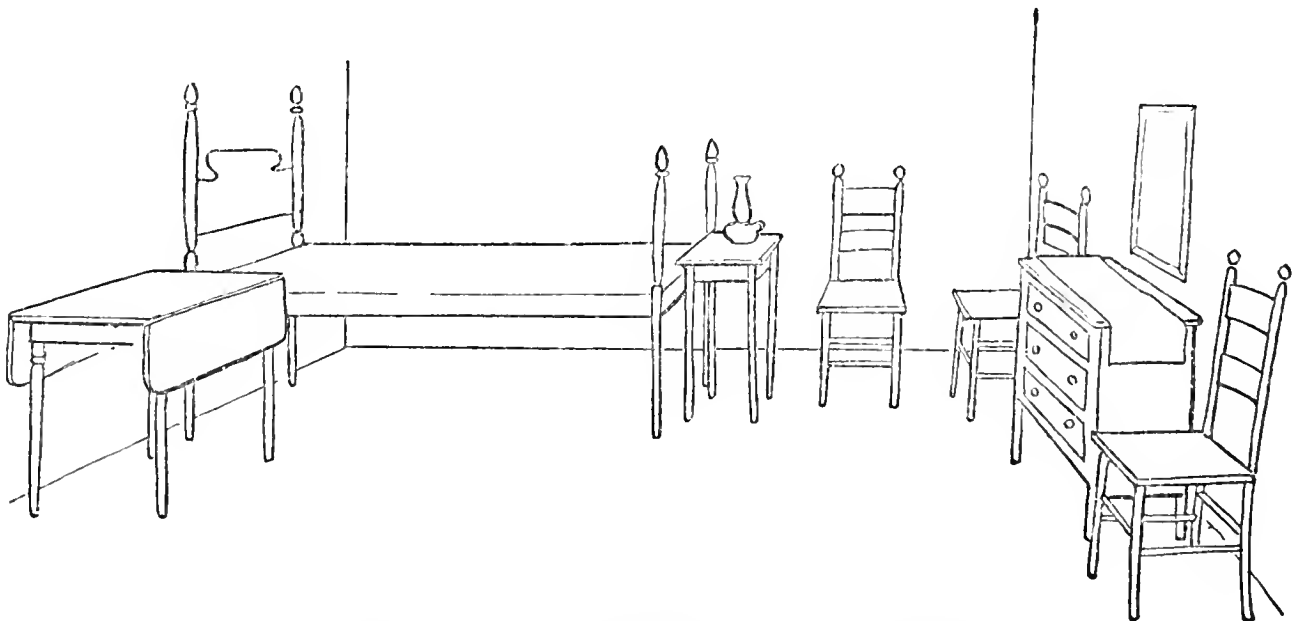

Fig. 34.—ROOM ARRANGED FOR DELIVERY.

### Arranging the Supplies

When the room has been cleaned, the mother's and baby's supplies should be arranged so that there will be no unnecessary delay in the preparations when labor begins. The midwife should tell the mother to put the cotton or the bag of clean rags to be used as wipes and the four basins away last, as they will be used first.

At this time the packages of sanitary pads should be sterilized. (See pp. 21, 45.)

The midwife should show the mother how, from the box or drawer of baby's supplies, to make up the baby's bed and a bundle for the baby's first oil bath containing—

- A. Flannelette square.
- B. Dress or nightgown.
- C. Six diapers.
- D. Shirt.
- E. Two soft, old, clean towels.
- F. Two small, soft cloths.

**To prepare the baby's tray.**—This can be done a day or so after the room is "house cleaned." The midwife should show the mother how to—

- A. Wash the tray, all the jars and bottles, the caps, and the new nipples in warm, soapy water. Rinse them thoroughly in clean water. Put the jars, bottles, caps, and lids in a kettle of cool water on the stove so that they are covered with the water. After the water is boiling, drop in the nipples and the rubber caps for the nursing bottles. Allow them to boil for 5 minutes.
- B. Remove the kettle from the fire, drain off the water, and allow the jars to cool.
- C. Make a supply of large and of small cotton balls.
- D. Remove the boiled jars from the kettle with a clean teaspoon without touching the inside of the jars. Turn them upside down on a clean dish towel. Put the boiled nipples and the rubber bottle caps into one sterilized jar and put on the cover. Put the large cotton balls in one jar and put on that cover. Put the small cotton balls into another jar and put on the cover. Cover and leave to be filled later the pint bottle or jar for the day's supply of boiled water, one jar for oil, and one for boiled water for washing the mother's nipples before and after she nurses the baby.
- E. Take one cake of white soap and stick the safety pins—six large and six small ones—into it ready for use. Put the other cake of white soap in the soap dish and cover it. Arrange the jars, nursing bottles, pint bottle for baby's boiled water, soap dish, and soap pincushion on the baby's tray.
- F. Cover the whole tray with the clean towel and put it in the confinement room out of reach of small children.

After the room and supplies are so organized, there is pleasure and security in knowing that things are ready for use at a moment's notice.

**SUMMARY**

The good midwife will help the mother make a plan for getting early all the supplies she needs for her delivery and the care of the baby. She will explain how each article is used so that the mother will understand why it must be "just so." She will check up with her from time to time to see that the mother is following the plan and will be ready in plenty of time. She will help her to have the best possible arrangement for the confinement room. She will make sure that it is "house cleaned" and that the supplies are conveniently sorted and easy to get at when labor begins.

## **Making a Delivery Bed**

### **A DEMONSTRATION AND PRACTICE PERIOD**

#### **Purpose**

To teach the midwife how to prepare a clean delivery bed and how to protect the mattress.

#### **Equipment**

One table, dresser, three chairs, one bed—made up as if slept in but with clean quilts or blankets—a table leaf or board, three clean sheets, one clean pillowcase, one clean blanket, newspaper pads with cloth covers, a generous supply of fresh newspapers, some large pieces of clean old muslin, hand basin, bucket of water, dipper, soap in dish, and paper towels.

#### **Procedure**

Wash your hands. Carry the clean sheets and pillowcase, one clean blanket, and a generous supply of newspapers to the bedside and put them over the head board or a chair back or on a table.

Strip the bed. Take off the upper clean quilt or bedspread and lay it over a chair to air. Take off the blankets likewise.

Strip the pillowcase from the pillow, put the pillow on the chair, and put the case on top of the soiled sheets that are still on the bed. Loosen the sheets from under the mattress and fold the ends toward the center. Roll up the soiled linen in a newspaper. Fix the mattress straight and firm on the bed. Put the table leaf or board under the mattress crosswise about where the mother's hips will rest.

Wash your hands.

Protect the mattress well with newspapers. Begin at the head of the bed on the far side and cover that side from the head to the foot. Use three thicknesses of papers at a time and place each three so they overlap the last three about 4 inches. Have the papers extend well over the mattress at the top and at the edge. After the far side has been protected begin at the head of the bed on the near side and cover that side with five thicknesses of paper overlapping the paper on the other side. Have each five thicknesses of paper overlap the last papers put in place.

This overlapping is important to insure good protection for the mattress (fig. 35).

Unfold a clean sheet and spread it on the papers. Tuck it well under the mattress at the top, sides, and foot. Show the midwife how she can favor the right side of the bed where the mother will lie if the sheet is a bit narrow.

Spread on the bed the top sheet and blanket or quilt. Turn them down at the top as you would in making any bed, and turn them up at the bottom instead of tucking them in. Tuck them in on the far side

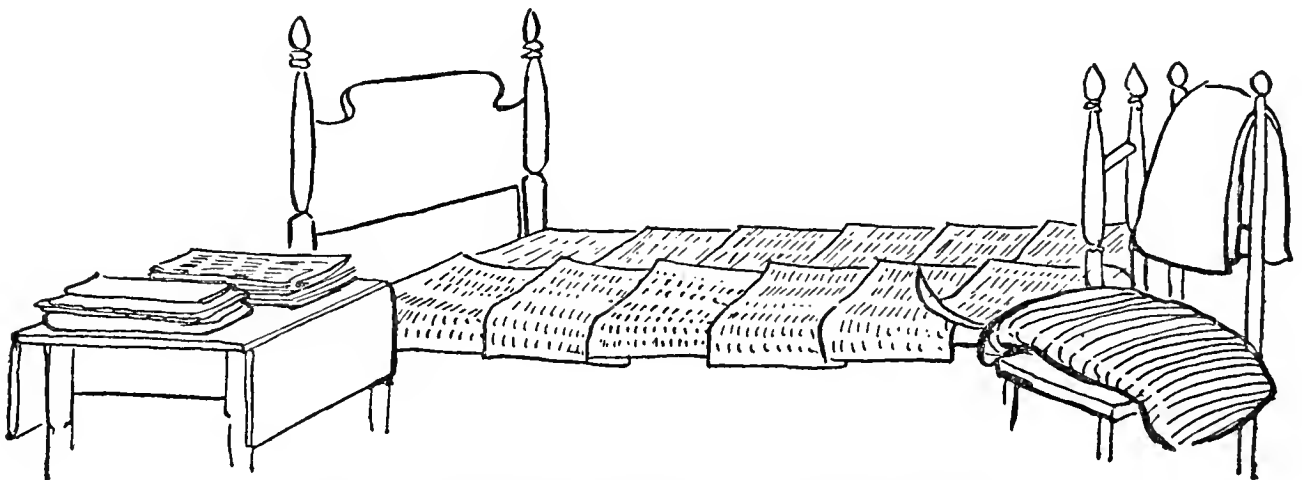

Fig. 35.—MATTRESS PROTECTED BY NEWSPAPERS.

and then fold this bedding to the far side of the bed so that it will be out of the way. Put the clean pillowcase on the pillow and adjust it on the bed.

Place a folded blanket and draping sheet over the foot of the bed.

Make three thick and three thin newspaper pans at this time on the bed so that the midwife can see what to do if there is no large table on which to work. Line one of the thick newspaper pans with a clean white rag tucked into the rolled edges and put it on the bedside table for the moment. Put the others on the dresser.

Place the first bed pad across the bed about where the mother's buttocks will be at delivery but extending over the mattress edge. Place the second bed pad lengthwise of the bed (fig. 36).

Then put the lined newspaper pan in place.

Make three large newspaper bags. Place one near the pillow on the bed to be used by the mother if she needs to spit. Place the second paper bag on the foot of the bed out of the way, to be used for soiled wipes. Place the third paper bag on the kitchen table to use for soiled wipes as you cleanse the baby.

Tidy the room and carry out the newspaper bundle of soiled linen.

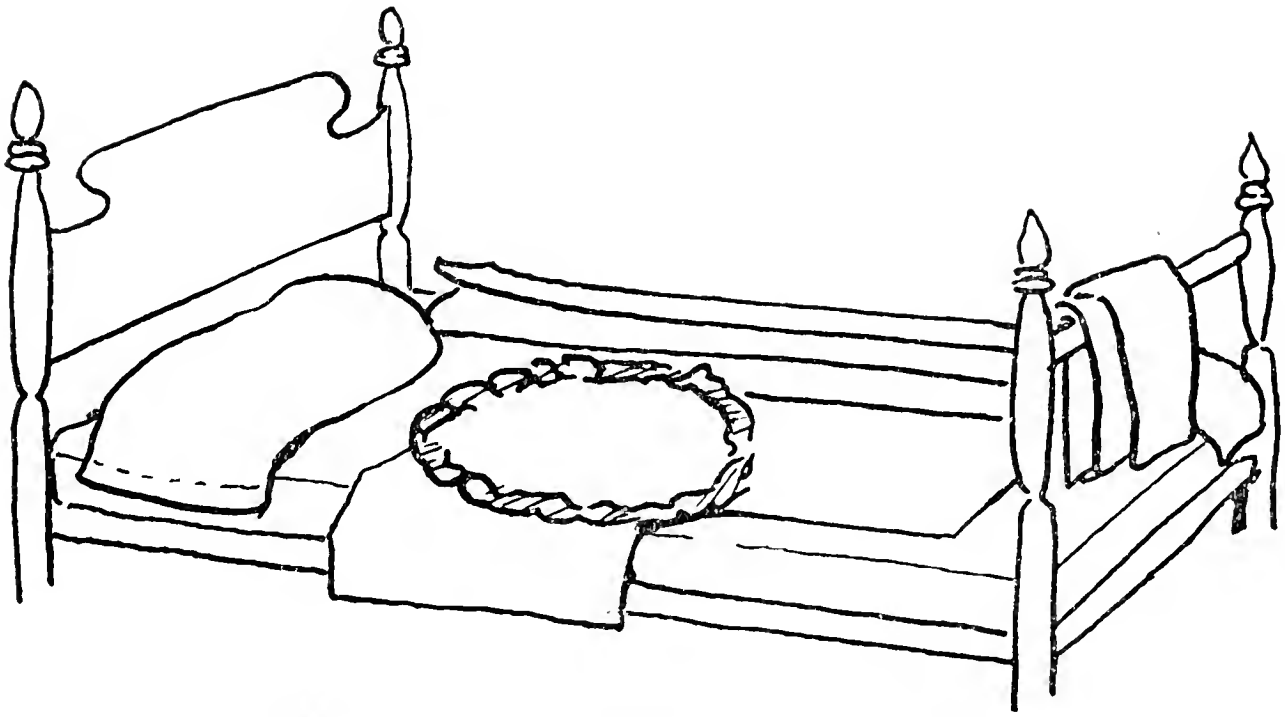

Fig. 36.—BED MADE WITH NEWSPAPER PADS AND NEWSPAPER PAN.

---

Be sure to emphasize the care that is necessary—

- A.* Not to stir up dust while preparing the bed during labor.
- B.* To make sure the mattress is well protected.
- C.* To see to it that the bed can be made ready for the delivery quickly, if labor should be short.
- D.* To keep the mother comfortably warm if it is at all possible. Use a hot stone or brick if the mother's feet should get cold.

---

After your demonstration watch each midwife strip the bed and make it.

## The Midwife's Preparation of Herself

### TEN-MINUTE REVIEW

When should all preparation of the supplies for delivery be complete?

What items of the baby's layette are most important?

What could you get for 10 cents which could be made to serve as a bed pan by adding a board?

Why should the room be prepared for delivery before labor begins?

If white rags are scarce, what might the mother prepare instead for the delivery?

Why should the midwife be notified as soon as labor begins?

What dangers may come to mother and baby if the midwife is late?

Give three signs of beginning labor.

If labor begins with painless bleeding, what should the mother do?

What may painless bleeding mean?

### The Maternity Situation

Explain the dangers of maternity. In the United States in 1939 about 9,000 mothers died from causes assigned to pregnancy and childbirth. Childbirth is a greater risk of death to women between 15 and 45 years old than is any disease or class of diseases except tuberculosis and diseases of the heart. Of the 9,000 women who died in childbirth in 1939, probably 4,500 could have been saved by proper care.

Forty-five hundred mothers' lives are not the only price we pay for poor maternity care. Many mothers are made invalids. Many babies are born dead and many others die after birth as the result of improper or insufficient care. In 1939 about 73,000 babies were born dead in this country and 66,000 babies that were born alive died before they were a month old.

**The midwife can help** to save the lives and health of mothers and babies—



- A. If she prepares herself for her work—
- a. By getting as much public-school education as she can.
  - b. By getting as much experience under supervision as she can to help her to develop good technique and skill.
  - c. By attending the classes for midwives that are given in her county or State.
- B. If she keeps herself in good condition—
- a. By being examined by a competent doctor to make sure she has no disease and carries no germs in her nose or throat that might be carried to the mother or the baby. She should not attend a birth if she has a head cold, sore throat, cough, or infection of the skin, particularly of the hands.
  - b. By keeping herself, her family, and her house clean and neat. Cleanliness helps to prevent disease. It will help her to keep well and to keep her mothers well. It will also set a good example for the mothers.
  - c. By calling a doctor if she or any of her family should become ill, to learn how to care for the ill person and to prevent the spread of disease from her house to any one else in the community. She should not attend a birth if there is illness in her own home.
- C. If she keeps her standard equipment in perfect order, clean, and ready to use at a moment's notice.
- D. If she uses her influence in the community to persuade every expectant mother to have a medical examination early in pregnancy and then registers only those mothers whom the doctor says it is safe for her to deliver.
- E. If she practices good midwifery—
- a. By keeping in touch during their pregnancy with the mothers she registers and reporting immediately to a doctor if all is not going well.
  - b. By helping the mother to conserve her strength during pregnancy and labor so that she will protect her baby, and to prepare the supplies that she will need to care for him.
  - c. By protecting the mother and baby from infection during and after labor (*a*) by being clean and using good technique, (*b*) by seeing that the mother prepares early the supplies she needs, (*c*) by seeing that the mother knows that she must call the midwife **as soon as labor begins** so that the midwife will have time to do everything in the best way, and (*d*) by not attending a birth if she has just attended a woman with an infection or with fever or if she herself or any member of her family is not well.
  - d. By following every rule and regulation of the town, county, or State department of health for the practice of midwifery and every detail of the teachings and advice of her supervisor.

Go over each of these points, explaining its importance. The midwife who promises to care for a mother in labor and at delivery is responsible for the life and health of two human beings. Good intentions alone will not save those lives. If the midwife is to deliver mothers safely, she must add to the best intentions in the world the good technique, wise judgment, and skill that come only when good teaching is followed by continuous effort to improve every detail of her work. When a real desire to be helpful leads to such careful preparation we can expect some reduction in the hazards to mothers and babies.

Midwifery is hard work. It takes a well, strong, intelligent woman to be a good midwife.

If the midwife delivers more than four mothers a year, she should have two sets of the standard equipment, so that she can be sure there will always be a clean one ready to use. A good midwife should have her bag ready for inspection at all times, and it should be absolutely clean with each article in good repair and in its proper place. The midwife should consider all the equipment soiled if the bag has been opened at all. Nothing but the standard equipment should ever be put into the bag. Nothing that belongs to the standard equipment should ever be used for any other purpose.

**To clean the equipment.**—Tell the midwife how to clean her equipment:

- A. Take everything out of the bag. Wash, boil, and dry outdoors in the sun, well out of reach of children and of animals, the lining, cap, midwife apron, wrapping for the apron, mask, towel, four muslin cases, hand scrub brush, and nail stick.
- B. Wash off the inside and the outside of the bag, using a clean cloth, soap, and water. Let the bag dry, out of reach of children and animals.
- C. Wash the hands just before touching the clean, dry goods, which should be ironed with a "spitting" hot iron on a clean ironing board.
- D. Wash, boil, and dry the scissors and safety pin.
- E. Inspect the silver nitrate (eye drops) for freshness and wash the outside of the box with a clean soapy cloth, rinse and dry it with a clean cloth. Replace the box if it is empty. Make sure a needle is in the box.
- F. Put glass connecting-tube into cold water and heat. When water is boiling drop into it the rectal tube, funnel, and rubber tubing and boil for 3 minutes.
- G. With careful use the pencil, birth-record book, and other stationery will not become soiled. They should be aired in the sun.

*H.* When everything is thoroughly dry, repack and close the bag tight. (See figs. 3, 4, and p. 21.) Before putting it away out of the reach of children or animals, wrap it carefully in wrapping paper to protect it from dust.

### **When the Call Comes**

The good midwife is always ready to answer a labor call. She keeps a freshly laundered dress and a set of clean underclothes wrapped in a drawer or a box where she can get them on a minute's notice. She keeps her nails short and smooth. She washes her hair every week and she bathes every day. She keeps her mouth clean by scrubbing her teeth and rinsing her mouth with salt water or some other mouth wash.

Explain that every call should be answered at once, as there is no way of knowing until the midwife sees the mother whether she is in labor and how much time there will be for the preparation for delivery.

Without losing one minute the midwife should bathe quickly, put on the clean clothes, take the clean bag that is always ready, and go to the mother by the quickest route.

## The Hand Scrub

### A DEMONSTRATION AND PRACTICE PERIOD

#### Purpose

To teach the midwife how and why she should scrub her hands and arms—to get rid of germs that might give the mother childbed fever and the baby blood poisoning or lockjaw.

#### Equipment

A clean basin, a soap dish or saucer containing a new cake of soap, a wooden nail stick, and a hand scrub brush on a chair protected with newspaper; a teakettle of hot boiled water on newspapers on the floor, and beside them on a newspaper on the floor the toilet bucket with a cuff of folded newspaper (fig. 37).

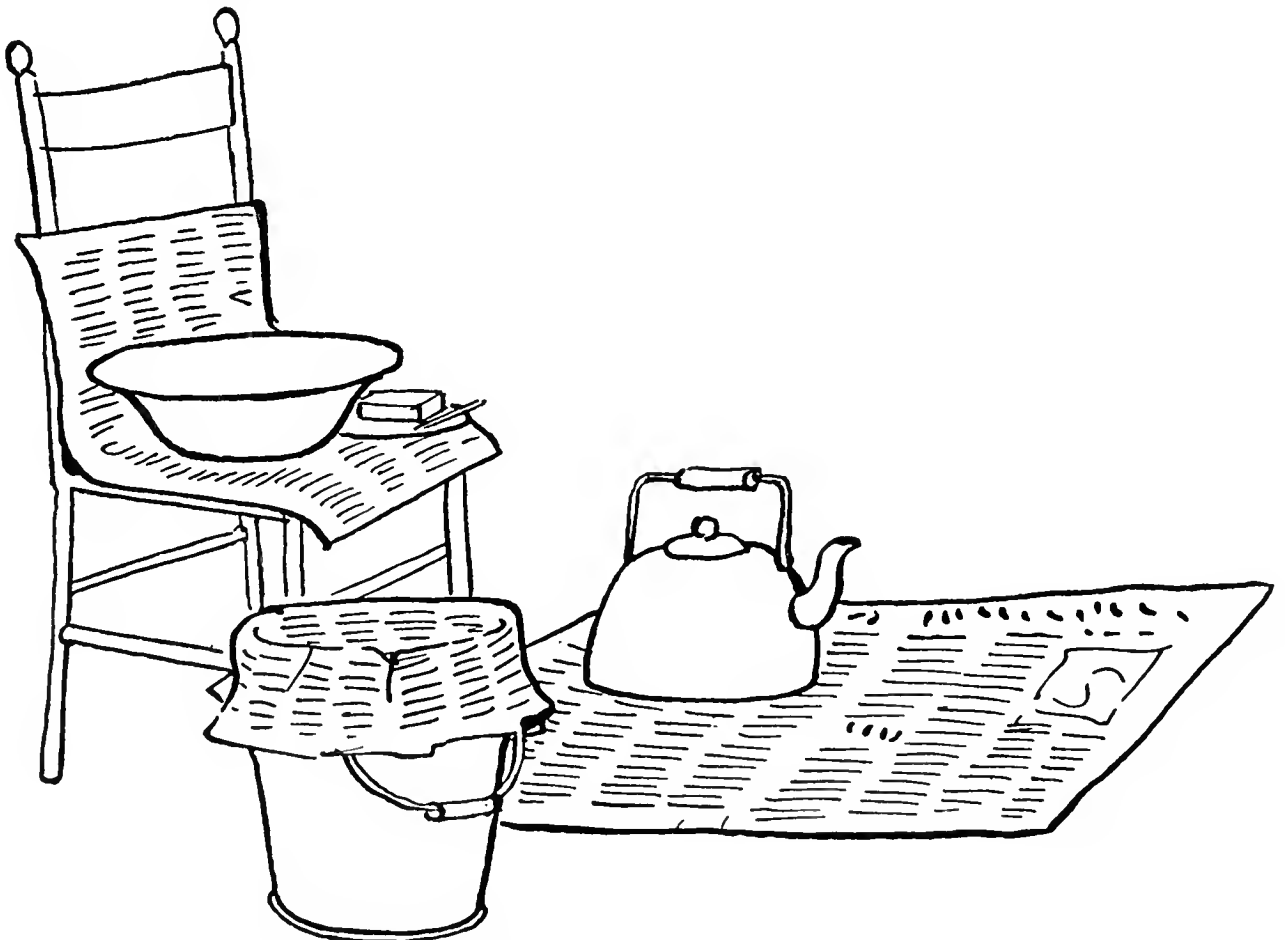

Fig. 37.—EQUIPMENT FOR SCRUBBING HANDS.

### Procedure

Explain the reasons for scrubbing the hands and arms thoroughly. Explain why the basin should be clean. Stress the importance of using only clean soap and a brush and a nail stick that have been boiled. A brush that has been used and not boiled is dangerous because it may have germs on it from some other mother.

Roll the sleeves above the elbow so that they cannot come down. Point out that you are not wearing rings or bracelets and tell why. Point out that your nails are cut short and rounded. Explain the danger of long nails picking up dirt and scratching the mother and baby or tearing the tender membranes of the baby's mouth if it should be necessary to wipe out mucus.

Pour warm boiled water from the teakettle into the basin. Explain why the water should be as warm as can be borne. Dip the brush in the water and rub the soap well into the brush. Using this brush and beginning at the elbow, systematically scrub each forearm and hand with quick vigorous action for 2 minutes. In scrubbing go all around the arm from the elbow to the wrists, then scrub the back of the hand and between and around each finger, and finish with the palm and the fingernails, on which the most time is spent. Rinse the suds off the hands and arms. Clean the nails with the nail stick and scrub the hands again with the brush, dipping the brush frequently into the water during the process.

Empty the basin into the bucket, rinse the soap dish and the basin thoroughly, and fill the basin again with warm water from the teakettle so that it will be ready for the next midwife to use.

Have each midwife practice scrubbing until she can do it perfectly. Watch her closely so as not to miss any errors of technique that might develop into habits.

## Labor

### TEN-MINUTE REVIEW

What is the midwife's responsibility in helping to prevent deaths in childbirth?

How can the midwife help to prevent early infant deaths?

Where does the midwife get her permit to practice midwifery?

Why should the midwife's bag be clean?

What do we mean by "clean"?

Why is it important that her equipment be complete?

### The Birth Canal

Tell the midwives briefly about the birth canal.

During the prenatal period the baby is in the uterus (womb) inside the mother's abdomen (belly). The uterus is a muscular bag with an opening at the bottom that is closed tight during pregnancy by two rings of muscles and a plug of mucus. Before the baby can be born these rings of muscles must be stretched open so that he can be pushed out of the uterus.

On the way out of the uterus and through the vagina (the last part of the birth canal) the baby must pass through the bony broad funnel that is formed by the hipbones, the lower part of the backbone, and the pubic bones in front. The normal passageway inside these bones is something like that in a curved stovepipe elbow (fig. 38, two views).

Any deformity of the bones might spoil the shape of the inside passageway so that there would not be room for a 9-month baby to pass through. That is why the doctor's examination early in pregnancy includes the measurement or X-ray picture of this bony passageway. (See p. 24.)

### Definition of Labor

The midwife must understand what happens in the mother's body during labor if she is to be intelligent in her care of the mother. Explain to her just what the processes of labor are. Labor is the name given to the process of nature by which the waters, the baby, and the afterbirth are expelled, or pushed out, from the mother's body by way of the birth canal. It is divided into three stages.

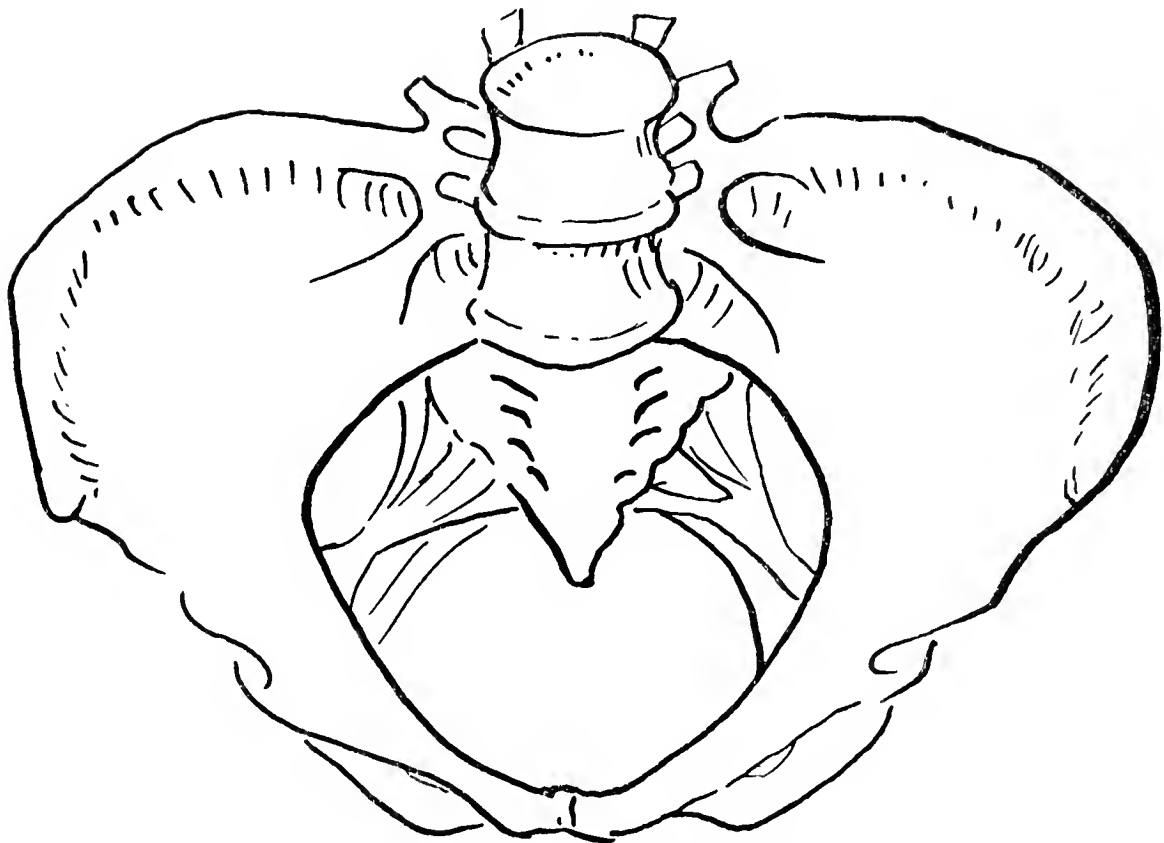

THE BONY RING THROUGH WHICH THE BABY MUST PASS.  
Front view of pelvic bones.

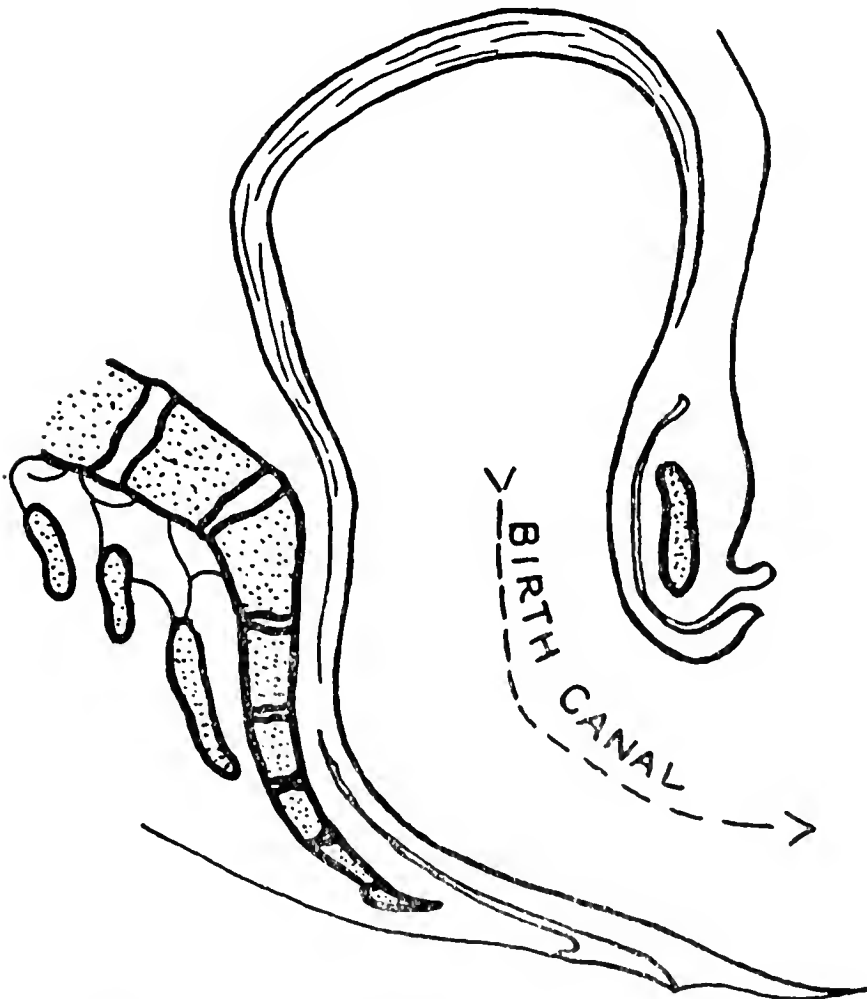

THE BIRTH PASSAGE IS SHAPED SOMEWHAT LIKE AN ELBOW OF A STOVEPIPE.  
Side view of birth canal (cross section).

Fig. 38.—TWO VIEWS OF BONY RING.

**The first stage**—the stage of opening the mouth of the uterus—lasts from the beginning of labor pains until the mouth of the uterus is stretched wide open. It may last from 12 to 18 hours when the mother is giving birth to her first baby and from 4 to 12 hours or even less when she has already had one or more babies.

**The second stage**—the stage of expelling, or pushing out, the baby—begins as soon as the mouth of the womb is completely open and ends when the baby is born. It may last from 15 minutes to 2 hours or more.

**The third stage**—the afterbirth stage—begins as soon as the baby is born and ends when the afterbirth is pushed out. It may last from 15 minutes to an hour or more.

Point out that normally it is always a force from behind the baby and afterbirth that pushes them out. The midwife should never pull or try to twist or turn the baby or the afterbirth. If they do not come naturally, she must call a doctor, for she is supposed to attend only normal, term deliveries.

### **The Muscles Used in Labor**

It is the muscles of the uterus and the abdomen that work during labor. When a muscle works it contracts (shortens) and pulls on whatever it is attached to. Sometimes a muscle's contraction moves some part of the body; sometimes it holds the part steady. Sometimes it stretches another muscle that is attached to it. A powerful workingman boasting of his strength will show how big and hard the muscle is in his arm. He lifts a heavy weight to his shoulder. The muscle on the upper arm bulges under the skin, and if it is felt with the fingers, it will be hard and firm. That is a contracted muscle—a working muscle. If a muscle gets overtired, it may stop working. If it becomes irritated, it may contract so tight that it cannot work normally for some time.

When labor begins the mother can feel the contractions of the muscles of the uterus. The midwife can feel them, too, by laying her hand on the mother's abdomen, just above the navel. During labor the muscles of the uterus work and then rest and then work again. While they work the mother has a labor contraction; while they rest she has no contraction. These contractions of the uterus usually cause the mother to feel pain. At first the contractions are short and the rests are long. Gradually the contractions last longer and are stronger as the muscles work harder, and the rests between contractions grow shorter and shorter.



Neither the mother nor the midwife can control the contractions of the uterus, but when the midwife understands what muscles are working during each stage of labor she can help the mother to help herself. By wise and careful management, enabling the mother to rest during each stage of labor, the midwife may keep the muscles from becoming overtired or irritated and so keep the labor progressing normally.

During the first stage of labor the muscle at work is solely that of the uterus. The contractions of the upper part of the uterus slowly but gradually stretch wide the muscular rings on the inner surface, then the ring on the outer surface.

**Demonstrating the first stage of labor with a bag and a doll.**—To show the midwife how the muscles of the uterus work to stretch the cervix (mouth of the uterus) so that the baby can be pushed through the opening, use a muslin bag having a double drawstring and containing a baldheaded doll whose legs and arms will fold up like those of an unborn baby. The folded doll must just fit the bag so that with the drawstrings pulled tight the bag will close over the doll's head.

Hold the closed bag containing the doll in both hands with the doll's head down, and the back of the doll's head forward. Explain that when labor begins the uterus is closed tight just as the bag is. Place both hands tightly against the bag and draw the hands closed, as the uterine muscle shortens during a labor pain. Explain how the uterine contractions pull on the muscular ring at the cervix until it is stretched open just as the bag is opened by the pull of your closing hands. Show how the opening is gradually stretched a little more and a little more with each pain (fig. 39, two views).

Explain how the bag of waters, when it does not break too soon, makes a smooth bumper in front of the baby's head that protects the soft lips of the uterus against bruising and also acts as a wedge inside the muscle ring to help stretch it open.

Point out that the stretching must be completed before the baby can be pushed out of the uterus into the vagina—the last section of the birth canal. Explain that during all this slow stretching the muscle work of the uterus is using the mother's strength and energy. The midwife who knows how to "manage" during labor will see that the mother's strength is kept up by having her rest between pains and by giving her some light nourishment with plenty of liquids every 2 hours.

The mother may have an idea that she should keep up and about and should try to help push out her baby as soon as labor begins. That

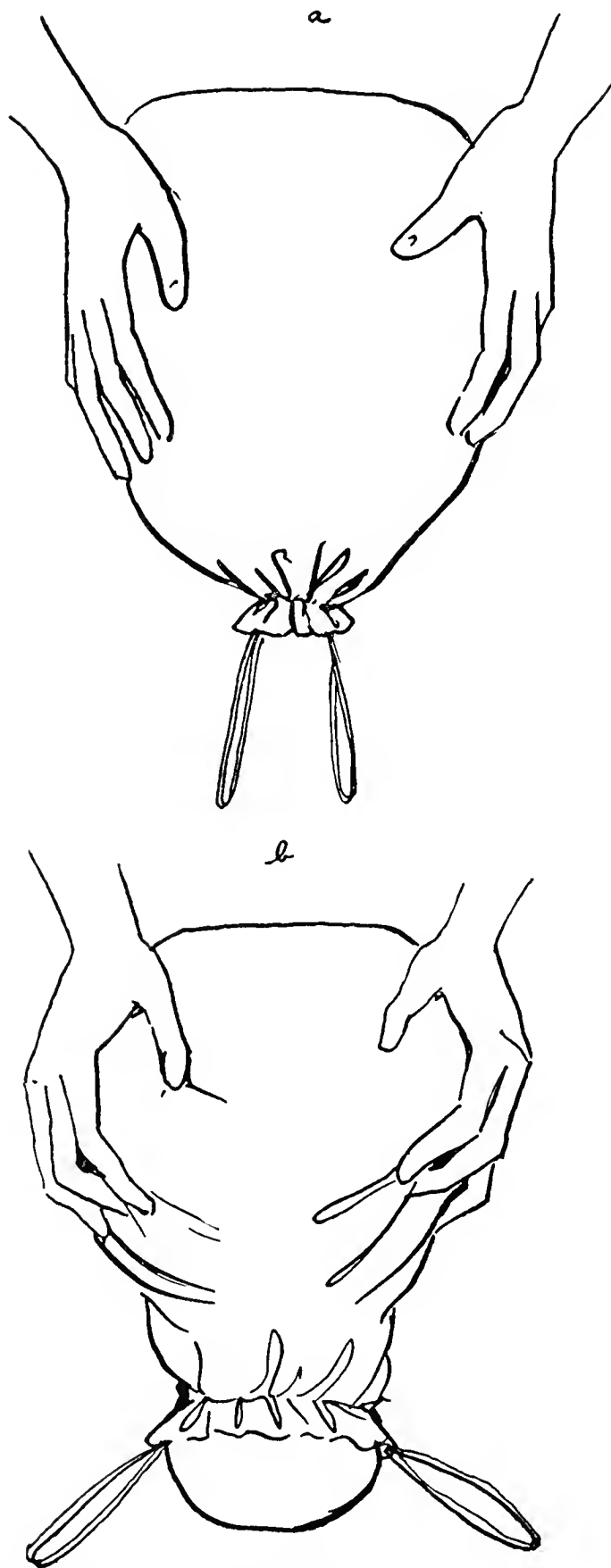

Fig. 39.—DEMONSTRATING FIRST STAGE OF LABOR WITH BAG AND DOLL—HOW UTERINE CONTRACTIONS OPEN THE CERVIX. TWO VIEWS.

idea is all wrong. The midwife should know how to explain **at the beginning of labor** the following:

That nature must stretch the opening of the womb before the mother can push out the baby.

That the mother must not begin to “push,” or “bear down,” until the midwife tells her to.

That she can help herself most by walking about the room a little, by resting often, by taking light nourishment, and by drinking water.

That she will be more comfortable and that labor will progress faster if her bowels are empty and she passes water often.

Then with the bag partly open show the midwife what happens when the doll is pushed down by pressing on its buttocks (fig. 40).

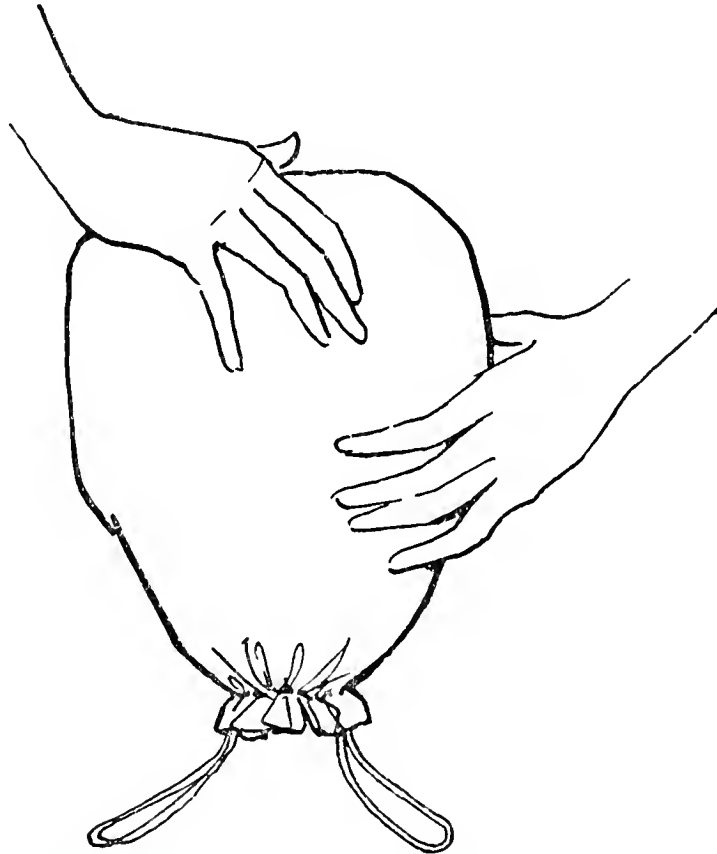

Fig.40.—DEMONSTRATING FIRST STAGE OF LABOR WITH BAG AND DOLL—WHY “BEARING DOWN” DURING FIRST STAGE DOES NOT HELP.

Explain how that is like the push on a baby when the mother “bears down” before the mouth of the uterus is stretched. Show that bearing down at this time does not stretch the opening because that can only be done normally by the even pull of the contracting muscles of the uterus all the way around the ring of muscles at its mouth. Explain how the waters are pushed to the side by each pressure on the baby’s buttocks and how the baby’s head forced against the soft lips of the uterus will bruise them. If repeated, this will irritate the ring of muscle and might cause it to contract so tight that it could not be stretched open until a doctor could give the mother an anesthetic. Explain that this is why the mother should not be allowed to bear down during the first stage of labor. Bearing down at this time does not shorten labor. It may even lengthen it and cause unnecessary injury and use the mother’s strength for nothing.

There should be no real bleeding during this first stage of labor. There may be some blood-stained mucus discharge. Tiny glands at the mouth of the uterus throw out a slippery watery secretion (mucus) which keeps the passage moist. Sometimes this discharge is blood-streaked because of the stretching of the mouth of the uterus and the separation of the membranes, but real bleeding is abnormal. If it occurs, a doctor should be called at once.

The waters should break when the stretching is complete. When they break earlier the mother has a "dry birth." When this happens the first stage of labor may be longer and the pains may be sharper because there is no bag of waters to act as a bumper or a wedge.

**The time to "bear down."**—Explain to the midwife the importance of watching the mother constantly for signs which will suggest that the stretching (the first stage of labor) is over and that the time to bear down has arrived.

Signs of the second stage of labor:

- A. Pains become more regular, more frequent, are harder, and they last longer.
- B. Mother may complain of nausea—sick stomach—may feel she must vomit; she may vomit.
- C. Mother feels her bowels should move or complains of a pain in the rectum. (The baby's head pressing on the rectum gives the mother a false idea that she is about to have a stool.)
- D. A small amount of mucus mixed with blood, the so-called "bloody show," comes from the birth canal.
- E. If the bag of waters has not broken earlier, it may do so now.

This is the time for the mother to begin to push out the baby. If she takes a deep breath as soon as she feels a pain coming, then holds her breath and "pushes" as long as the pain lasts, just as if she were trying to move her bowels, she can add a great deal to the force behind the baby, and every pain will bring the baby a little farther on his way out. She should rest between pains so that she can "use every pain." This is the way she can help herself most and really shorten labor. With each contraction the vulva will bulge and open, and the baby's scalp can be seen.

When the baby begins to move down through the birth canal the mother may have pain in her back and legs. It will be a relief for her to straighten her legs and stretch her toes as far down as she can between pains. It will also help for the midwife to rub her back if it aches.

If her rectum is not empty, the mother may move her bowels as she bears down and the stool will soil everything that has been so carefully cleansed to prevent infection. That is why an enema is given early in

labor (see p. 76), so that there will be no material left in the rectum to be pushed out during the second stage.

**The time to “pant.”**—The baby’s head can be born more easily if the mother does not bear down with the pains just as it is coming out. Too much force behind the head at that time would push it out too fast and might tear the edges of the birth canal. When the head is coming out it is better for her to “pant like a dog.” The midwife should teach her how to do this when she teaches her how to “hold her breath and push.” The midwife should be sure that the mother understands and then have her promise to stop pushing and begin to pant the minute the midwife says, “Pant.”

Then, when the contraction is over, the midwife can let the mother push again but she should push just a little, so that the head and shoulders will come through slowly and not tear the edges of the birth canal. If the edges should be torn, the midwife must call a doctor to mend the tear to prevent the mother from having “body trouble” later.

**The afterbirth.**—After the baby is born, the mother will have a few minutes’ rest. Then there will be a few more contractions so that she can push out the afterbirth. As soon as the uterus is empty its muscles contract in still another way to lessen the bleeding from the area on its inner surface where the afterbirth was attached. If more than one cup of blood comes with the afterbirth, the uterus is not contracting properly and the midwife should send for a doctor at once, in the meantime massaging the wall of the abdomen to make the uterus contract.

### **Duration of Labor**

Usually the labor at the birth of a first baby is the longest, for the first stretching of the mouth of the uterus is a long, slow process. The succeeding labors may be much shorter. The mother who has had many babies or who is overtired or poorly nourished may have longer labors because her muscles do not work so well. The mother whose abdomen is very large during pregnancy may have a long labor because her muscles have been stretched till they have lost some of their power to contract. The mother with the very large abdomen should be watched with great care for bleeding after the baby is born, because her stretched muscles may not contract as much as they should when the afterbirth has separated from the wall of the uterus. The midwife who understands the mother’s need of care during the first stage of labor can so manage the mother’s “work” (bearing down), rest, nutrition, and elimination as to help prevent many complications in the second and third stages of labor.

## Preventing Infection

Point out to the midwife why the whole birth canal must be protected from infection. The large area where the afterbirth was attached to the inside of the uterus is just like an open wound—warm, moist, dark—a place for disease germs to grow and cause childbed fever, milk leg, a whole train of other ills, or even death.

In the uterus there will be a raw surface and in the birth canal tiny tears that would allow germs to get in and grow. If disease germs get into the birth canal it is almost impossible to keep them from growing and spreading up into the uterus. So disease germs must be kept away from the birth canal before, during, and after labor and delivery.

### What the mother should do :

- A. Keep her body, clothes, and house clean all during pregnancy so that there will be fewer germs around.
- B. Take sponge baths instead of tub baths during the latter part of pregnancy so that germs from the bath water cannot get into the vagina.
- C. Take no douches during pregnancy, keep her fingers away from the vulva, allow no one except a doctor to examine her internally with instruments or fingers, and have no sexual intercourse after the seventh month of pregnancy until 6 weeks after delivery.
- D. Have the room, bed, bedclothes, and supplies that the midwife will need clean and ready in time, and call the midwife as soon as labor begins so that she will have the time and the things she needs to do everything in the right way.

### What the midwife should do :

- A. Teach and help the mother to do her part and be sure the husband understands, too.
- B. Keep her own house, her clothes, and her body clean at all times so that there will be fewer germs around.
- C. Come to the mother's house with her equipment clean and herself bathed and dressed in freshly laundered clothes so that she cannot transfer germs from another mother.
- D. Wash her hands and put on her cap and mask before she does anything for a mother in labor; prepare the supplies and scrub her hands and put on the midwife apron before the delivery.
- E. Prepare the mother in every detail according to instructions—without fail, every time—to remove any germs that may be near the birth canal.
- F. See that nothing—water, oil, fingers, or instruments—is put into the birth canal during or after labor.

Be sure the midwife understands that it is childbed fever that kills many mothers every year and that most of them die because someone—

the mother, the father, the midwife, or the doctor—was not clean and careful.

### **The Baby**

Many babies die a few hours or days after they are born because they are not cared for properly at birth. The care of the baby comes in another lesson, but his immediate needs must be mentioned here, too, because the midwife must understand **why** he needs special care as soon as he is born. He must be separated from the afterbirth, watched to be sure he can breathe properly, and protected from infection, injury, and chilling. If he does not have good color, if he does not cry and breathe naturally, or if anything else is wrong, a doctor must be called at once.

As the baby's eyes may be infected by discharges from the birth canal, his face should be wiped clean and his hands kept away from his eyes until the drops can be put in them. (See p. 85.)

The cord should be tied securely in two places with sterile tape because blood vessels that go into the baby's belly are cut and they must be kept from bleeding. The cord should be cut with sharp, sterile scissors because germs must be kept away from the cord stump so that they do not get into the open blood vessels. (See p. 105.)

The baby has come from a warm place, and special care must be taken to keep him warm until he can get used to the cooler air outside his mother's body. He should be wrapped in the warmed blanket which has been placed ready to receive him and which is fastened snugly to keep his hands and arms inside. He should be laid in his bed with his head lower than his feet so that mucus can drain out of his mouth and nose. The bed should be so placed that the baby can be watched to see that he does not choke, that his color is good, that he does not bleed from the cord, and that he does not get uncovered.

### **The Midwife's Responsibility**

When the processes of labor have been thoroughly discussed so that the midwife really knows what the muscles are doing and how labor should progress in each stage, emphasize her great responsibility for protecting the mother and the baby from fatigue, chilling, injury, and infection. Emphasize that when everything is normal nature, working through the mother, delivers the baby. The good midwife manages the whole situation so that nature will not be interfered with when everything is normal, and calls a doctor at once if labor is not progressing or if anything goes wrong.

**Managing** means:

Answering a labor call immediately so as to make the necessary preparations in the best way to prevent infection.

Seeing that the mother has rest, nourishment, and fluid and keeps her bowels and bladder empty.

Encouraging her as labor progresses.

Helping her to "push" and to "pant" at the proper times during the second stage of labor.

Watching her every minute all during labor so as to be sure to get a doctor in time if all is not going well.

Giving the baby proper care as soon as he is born.

The midwife who manages well is a great power in the community. Every time she attends a woman in labor she stands guard over the life of a mother and a baby and works with God and nature to keep alive the precious spark of life from generation to generation. It is no wonder the people "rise up and call her blessed."

The midwife who tries to hurry nature, who does not call a doctor in time, who is careless about protecting the mother from infection, who neglects a baby, is a menace not only to that mother and baby but to the whole community.

It might be a good idea to close this lesson or the whole institute with an impressive ceremony when each midwife would be asked to sign a solemn pledge promising to guard the life of every mother she attends during pregnancy, at delivery, and after delivery and to cherish every baby as if it were her own, by being clean and careful all day and every day, by following to the least detail the instructions for the care of mother and baby, by urging all pregnant mothers to go to good doctors for examination early in pregnancy, by helping them to follow the doctor's advice, and by calling a doctor whenever she is not sure that everything is going well.

**SUMMARY**

The midwife who would give intelligent care to a mother must manage the whole situation during each stage of labor with three things in mind: The birth canal or **passage** through which the baby comes into the world, the "**powers**" that push him out of the mother's body, and the **passenger**, the baby himself.

The **passage**, if the mother is to have a normal delivery, must be large enough for a full-term baby to come through and must be free from deformities so that there will be nothing sticking out to catch the baby's chin or shoulder. It is important for the midwife to know about this early in the pregnancy—one more reason why the doctor's examination



of the mother should be made before the midwife promises to care for her. The doctor will take measurements of the pelvis. If there is any doubt that the passage is normal the doctor may want X-ray pictures. If the passage is not normal, he will want the mother to be in a hospital for the labor.

When the midwife is caring for a mother with a doctor's assurance that the passage is normal, she should never forget for one second that she must keep disease germs from getting in or near the passage. She should remember that if the mother is torn during delivery, the tear must be repaired by a doctor.

The "**powers**"—the muscle contractions—must be strong enough to push out the baby or the mother cannot have a normal delivery even when the passage is normal. The strength of these powers cannot be tested during pregnancy. No one can tell how a muscle will work at a given time. No one can be sure that a big, strong woman will have strong powers during labor or that a little, frail woman will not have. The woman who has lived wisely during pregnancy (see lesson III, p. 36) will be more likely to have enough power to deliver her baby normally than the mother who has been overtired and underfed. The mother who has had many babies or has had the muscles of her uterus stretched by much fluid or by big babies may not have muscles strong enough to push out the baby normally.

The midwife must be on her guard every minute to save the mother's strength by seeing that she rests between pains, that she takes some nourishing fluid every 2 hours, that she does not waste her strength and slow up the progress of labor by "bearing down" before the signs appear that the stretching of the mouth of the uterus has been completed, by teaching her when and how to "push" and "pant," and by keeping her encouraged as labor progresses. If the mother seems to be tired, if the pains grow weak or stop, or if the baby does not seem to be coming along normally after the mother has had an hour of second-stage pains, the midwife should call a doctor.

The **passenger**—the baby—must be kept in mind during labor. Everything must be put in readiness for him. His clothing, his bed, the receiving blanket must be warm to receive him so that he will not be chilled. The sterile cord scissors, ties, and dressing and the eyedrops must be at hand, and the toilet tray ready in a warm place for his first oiling and drink. He must be watched so that a doctor can be called at once if all is not as it should be.

## **The Soapsuds Enema**

### **A DEMONSTRATION AND PRACTICE PERIOD**

#### **Purpose**

To teach the midwife why, how, and when to give an enema to a woman in labor. To warn her when she should not give an enema.

#### **Equipment**

As the enema is usually given during the first stage of labor, the room should be arranged as described in lesson XII (p. 88), the bed made for delivery, the midwife's hand-scrub equipment ready to use, and her other things and the mother's supplies conveniently arranged in the mother's room and the kitchen. There will be newspapers, toilet paper, grade-B absorbent cotton or clean dry rags for wipes, a bedpan, thick newspaper pans, newspaper bags, and a toilet bucket in the mother's room. The mother's soap in a saucer and the basin she uses for a sponge bath and a clean pitcher or jar will be at hand. The mother will be up and about wearing a nightgown, kimono, stockings, and slippers. The midwife will be dressed in a wash dress and wearing her cap and mask. The doll and the supervisor who is demonstrating to the class should be dressed accordingly.

#### **Procedure**

Tell the midwives that an enema for a woman in labor means warm, soapy water poured into the rectum (back passage) through a rubber tube to stimulate the lower bowel to empty itself so that the rectum will be empty during labor and delivery. The heat and pressure on the uterus from the rectum filled with the warm soapy water usually will also stimulate the uterus to contract and the bladder to empty itself.

Explain that an empty lower bowel and bladder leave more room for the lower birth canal to stretch as the baby passes along it. Their being empty also helps to prevent injury to the bowel and bladder walls from the pressure of the baby (fig. 41, two views).

If the rectum is not emptied early in labor, the bowels may move during delivery, and some of the feces may get into the birth canal and cause infection. So an enema not only helps delivery by emptying the

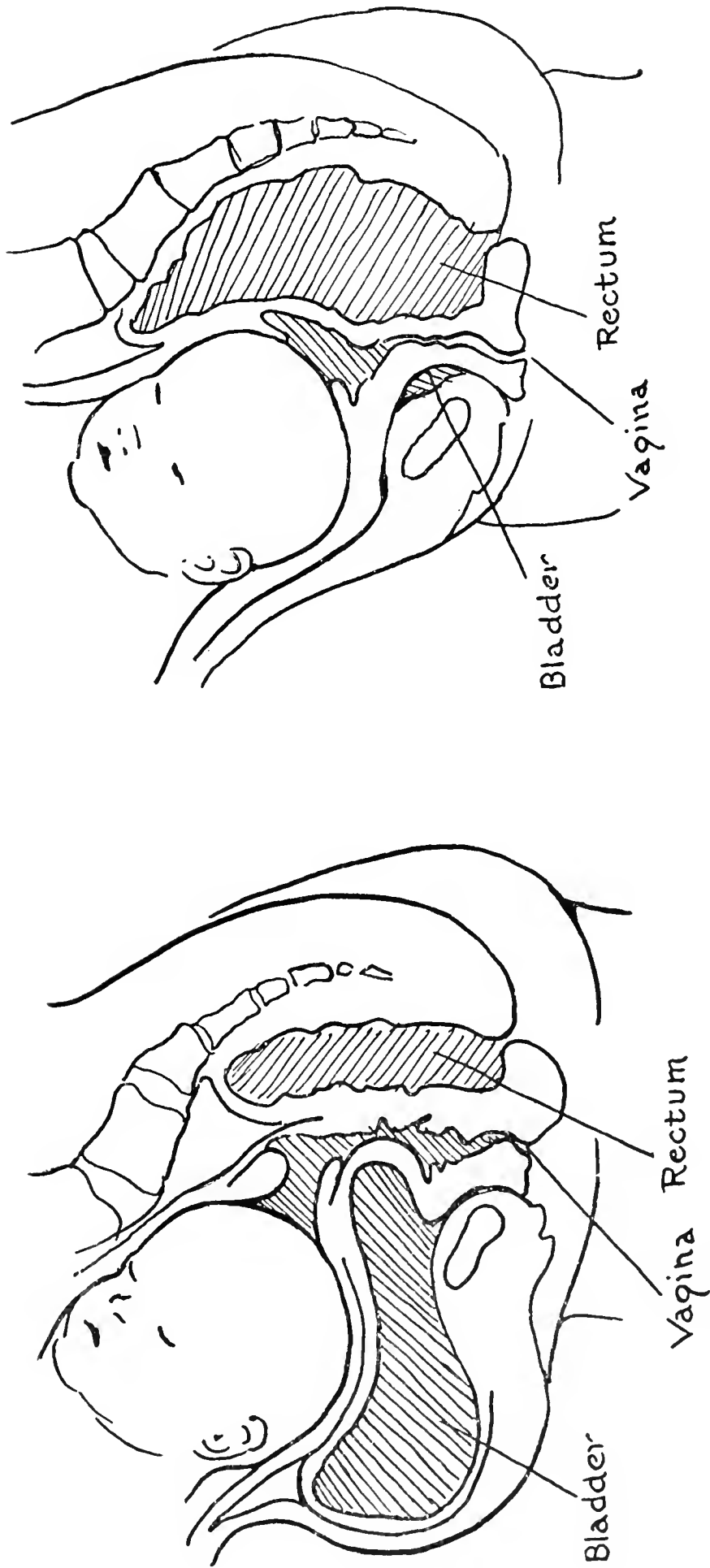

Fig. 41.—RELATION OF FULL BLADDER AND FULL BOWEL TO POSITION OF BABY'S HEAD.

rectum and bladder and stimulating the uterus to contract but prevents soiling and possible infection.

Tell the midwife of the importance of learning before giving an enema when the mother passed water last and how much fluid she had had to drink in the last few hours. If she had had little to drink and had not passed water recently, she should have two glasses of hot water, weak tea, or coffee to drink while the midwife is preparing the enema, so that she can pass water easily when she expels the enema.

Warn the midwife not to give an enema without advice from a doctor if the bag of waters has broken, if the pains are coming hard and close together, if the baby's scalp is in sight, if the baby's cord, his hand, foot, or buttocks can be seen coming down in the birth canal, if there is bleeding, or if there is any other danger signal. Emphasize why danger signals mean sending for a doctor at once.

When you are sure the midwife understands when and why to give an enema and when and why not to give one, show her just how to prepare and give one to a mother in labor.

**Preparing the enema.**—Into a pitcher or a jar pour a little hot water on the white soap in the mother's supplies. While it stands for a few minutes see that the rim of the toilet bucket is protected with folded newspaper. Then shake the soap and water well and add enough warm water to fill the pitcher or jar. Take out the soap and skim off the soap bubbles. The soapy water should feel warm to your hand. Place the pitcher of soapy water in a hand basin. Connect the funnel, rubber tubing, glass connecting nozzle, and rectal tube and put them in the basin beside the pitcher. Fit a piece of toilet paper or clean wipe over your index finger and put some unsalted lard on it and wrap it around the end of the rectal tube. Carry the basin and its contents to the bedside.

**Preparation at the bedside.**—Explain the purpose of the enema to the mother (demonstrate with the doll) and tell her just what you are going to do. Urge her to help by breathing through her mouth if she has a labor pain while you are giving the enema and to let you run in as much soapy water as she can hold to allow the enema to help her as much as it should.

Arrange the equipment on a bedside chair well protected with newspapers. See that the toilet bucket is on newspapers on the floor beside the bed, and the roll of toilet paper within reach.

**Preparation of the mother.**—Ask the mother to take off her kimono and lie on the bed. Cover her with the draping sheet. Place the small blanket from the foot of the bed over her upper body to prevent chilling and exposure. See that a thick newspaper pan is under her

hips and turn her on her left side with her hips even with the edge of the bed and with the right knee well drawn up. Turn her nightgown up out of the way.

**Giving the enema.**—Place the basin and its contents on the bed beside the mother's knees (fig. 42). Hold the funnel in your left hand and

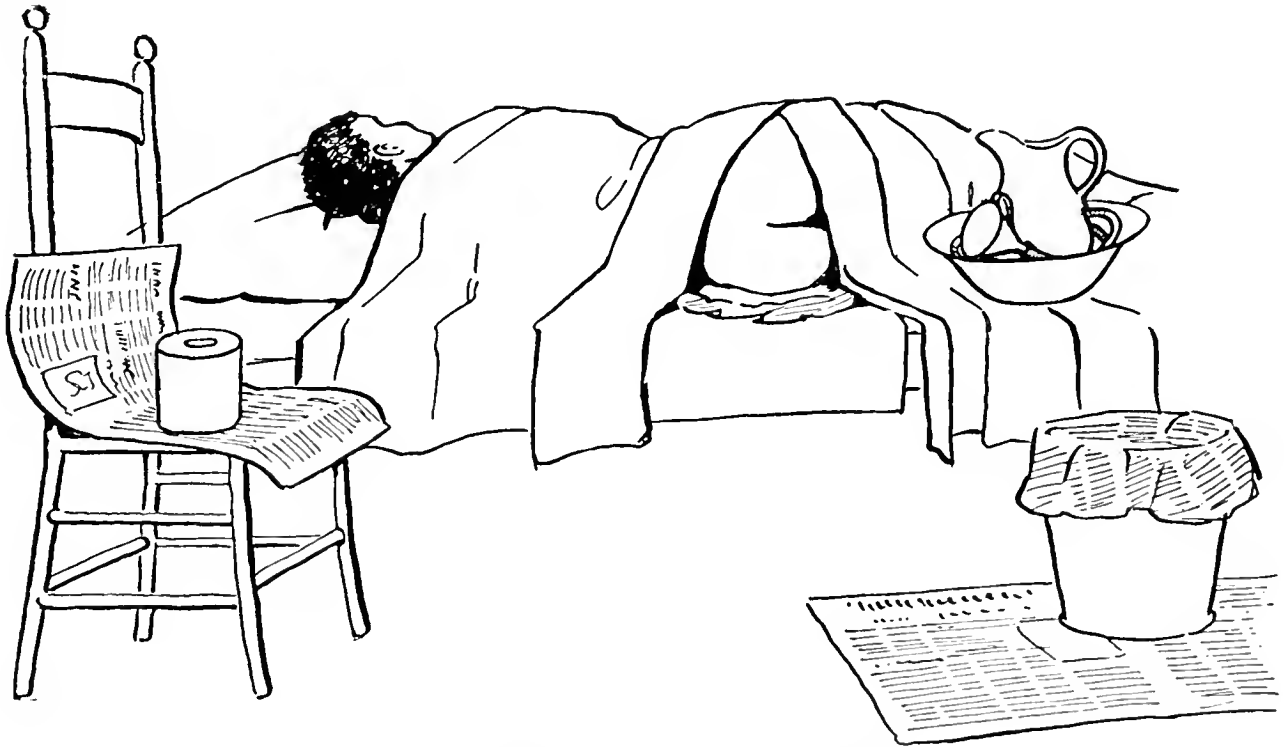

Fig. 42.—PREPARATION FOR ENEMA.

form a loop in the tubing by pinching it in two places with the same hand (fig. 43). Then pour some of the soapy water into the funnel. Put the pitcher down in the basin and let go of the tubing. Let the soapy water run through the rectal tube into the bucket to warm the tube and expel the air. Pinch off the flow again before the funnel is empty.

Look carefully to see if there are varicose veins or hemorrhoids (piles) around the mother's anus. Take great care to avoid hurting the mother as you insert the tube into the rectum. A well-greased tube will go in easily. If it has a tendency to slip out, ask the mother to hold it in place (fig. 44).

Pour some more soapy water into the funnel and set the pitcher in the basin again. Allow some of the water to run slowly into the bowel and put the rectal tube in gradually as far as 6 to 8 inches. Hold the funnel just high enough above the anus to keep the water flowing slowly. Six to twelve inches is usually high enough. The rectum will be emptied more completely if the soapy water runs in very slowly.

Refill the funnel each time just before it becomes empty so that no air can get into the rectum.

Explain about lowering the funnel a little to slow down the flow if the mother has a pain or complains of cramps and about pinching the tube to stop the flow for a few seconds. Show how when the mother is sure she can hold no more you would pinch the tube while there is water in the funnel and withdraw it slowly, with one hand pressing a wad of toilet paper or wipes against the anus. This will help to prevent the escape of fluid when or immediately after the tube is withdrawn.

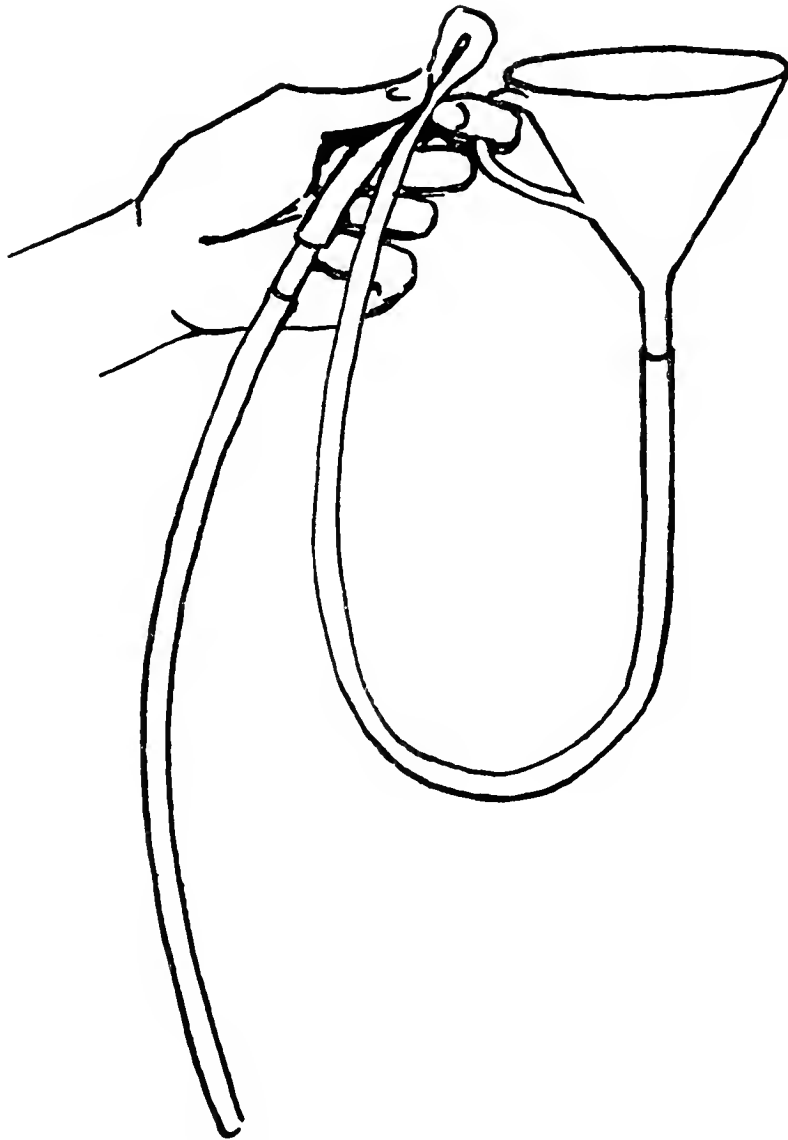

Fig. 43.—FUNNEL AND PINCHED TUBE USED FOR ENEMA.

Hold the funnel up and let the water from the funnel run through the tube into the bucket. This will rinse the inside of the tube. Wipe the end of the rectal tube with toilet paper. Disconnect the rectal tube from the glass connecting nozzle and wrap the rectal tube in newspaper. Then put it and the pitcher, funnel, rubber tubing, and glass connecting nozzle in the basin and set them aside to be cleansed later when the mother can be left.

Dry the mother with toilet paper and help her to turn on her back. Describe how when she thinks she can hold the water no longer you would

help her to get up to expel the enema in the toilet bucket. While the mother is on the bucket the bed should be straightened, any moist or soiled articles should be replaced by clean dry ones, and the draping sheet and small blanket should be folded at the foot of the bed if she does not need either around her shoulders.

Explain why the mother should never be allowed to go any distance away or to an outside privy but should be watched carefully because the



Fig. 44.—GIVING ENEMA.

enema may be followed immediately by severe second-stage pains. She should not be left alone in the room. If, while the mother is using the bucket, the pains should suddenly become very severe or if she should complain of a desire to bear down or if there should be any bright red show, she should be helped at once into bed, where she can be watched and controlled more easily, and should finish the expulsion of the enema on a bedpan.

Explain that after the mother has finished emptying her bowels and has passed water if that is possible, you would look at the contents of the toilet bucket to judge whether the enema had all been returned and to see if the mother had had a good bowel movement; use toilet paper to

wipe the surface from the birth canal back over the anus; help her into bed when she is clean; cover her; cover the bucket with a lid or with newspapers; ask a member of the family to empty the toilet bucket, wash and scald it, and bring it back to the delivery room.

While the mother is resting a few minutes lay the enema equipment on a fresh newspaper out of the way so that you can wash the pitcher, the basin, and your hands thoroughly. Fill the basin with warm water for washing the mother. Explain that when there is time and a basin that will not be needed, the rectal tube will be washed in soapy water and rinsed; the funnel and nozzle will be put in the basin with some warm water and put on the stove to boil. As soon as the water boils hard the rectal tube and connecting tube will be dropped into the boiling water and boiled for 3 minutes. When the equipment is dried it is ready to be put in its muslin case.

Bring the basin of warm water and the mother's soap in a saucer to the bedside. See that you have 18 or 20 clean dry wipes ready. Have the mother lying on her back. Put a thick newspaper pan under her hips. Turn back the covers and put the draping sheet over her. Put the blanket from the foot of the bed across her upper body. With one of the clean wipes moistened and well soaped wash her abdomen thoroughly from the ribs to the vulval-hair margin. Do not let any water run or drip on the vulva. Throw this wipe away in the newspaper bag, moisten a clean one, and rinse the abdomen. Throw this wipe away and dry with another clean wipe. Wash, rinse, and dry first one thigh and then the other from the knee to the groin, throwing away each wipe as before. Turn the mother on her left side and, using more wipes, wash, rinse, and dry the buttocks and the anus. Be careful to keep water from running or dripping on the vulva. With a clean wipe and plenty of soap wash thoroughly about the vulva, explaining why you do not open the lips nor allow any soapy water to enter the birth canal. Throw away the soapy wipe in the paper bag. Rinse off the soap with a second wipe and dry carefully with another one.

Straighten the bed and leave the mother to rest a few minutes while you wash the soap, soap dish, and basin and scrub your hands.

Explain that if second-stage pains had begun you would have washed the mother with boiled water and wipes as shown in lesson XIII (p. 101) and would have kept her in bed. If there are no second-stage pains and no leaking, it is well for the mother to walk about a bit again after a few minutes' rest.

Have the midwives practice (with the doll) how to handle the enema equipment—hold the funnel, pinch the tubing, fill the funnel, and so forth—and wash the vulva and buttocks.



## The Care of the Baby's Eyes

### A DEMONSTRATION AND PRACTICE PERIOD

#### Purpose

To show the midwife how and to help her understand why she should protect the eyes of the newborn baby against infection.

#### Equipment

A table in a good light with a clean wrapping-paper cover. On it or on a chair near it a newspaper bag; paper wrapper of the sterile cord dressing containing two cotton balls; a box containing two new wax ampules of silver-nitrate solution and a needle; a baby doll with a binder on, wrapped in a receiving blanket and lying in the baby bed well covered; hand basin; bucket of water; dipper; soap in dish; and hand scrub brush (fig. 45).

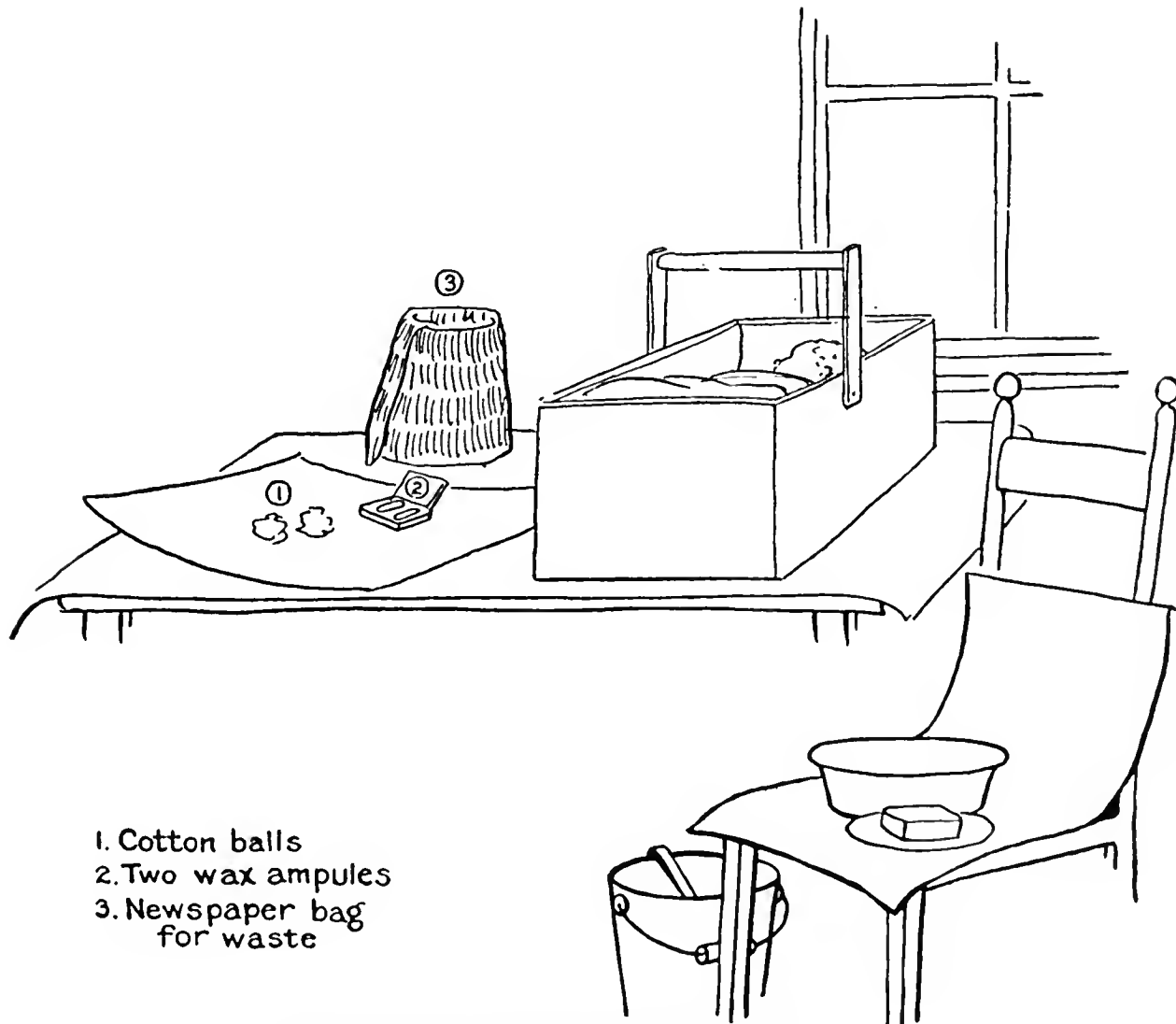

1. Cotton balls
2. Two wax ampules
3. Newspaper bag  
for waste

Fig. 45.—CARE OF THE BABY'S EYES.

## Procedure

Explain that **every baby's eyes need special care** because germs from the birth canal may get into them as he is being born. After the baby is born there is still danger of infecting his eyes if the discharges from the birth canal are carried to his eyes by his own hands or by the fingers of the doctor, nurse, or midwife, or, later, of the mother. Because germs which cause the mother no symptoms or discomfort may irritate the baby's eyes enough to cause blindness, the eyes of the baby whose mother has had no discharge from the vagina during pregnancy need just as much care as the eyes of the baby whose mother has had such a discharge.

In most States there is a law which requires the doctor, midwife, nurse, or other person in attendance on a confinement case to put two drops of a silver-nitrate solution in each of the baby's eyes soon after birth. And most State departments of health will supply the silver-nitrate solution in wax ampules free to doctors and midwives. Even if there is no State law about using the eyedrops, the conscientious midwife is morally responsible for using them to protect the eyes of the babies she delivers.

Be sure that the midwife knows where to get the eyedrops. Be sure that she can explain what she must do to comply with the law or with the practice approved by the department of health in her own State. She should also be able to explain to the family why the eyedrops are used. Some parents object to them because they think "babies' sore eyes" are caused only by the gonorrhoea germ and that the drops are not necessary when the mother has had no discharge during pregnancy.

Both ideas are wrong. The gonorrhoea germ causes only about half the eye infections at birth. The other germs from the birth canal that may infect babies' eyes during or after birth may or may not cause the mother to have discharges from the vagina during pregnancy.

The midwife's responsibility for the care of the baby's eyes does not end when she has put the drops in them. In the daily care of the baby she must make sure that nothing (her hands or the mother's hands, bedclothes, or nightgown) which is soiled with the discharge from the vagina after a baby is born touches the baby's clothes, hands, or eyes. Everyone who touches the baby should wash the hands first, and no one should touch the baby's eyes except the person who wipes his eyelids gently with a clean washcloth and towel when giving him his bath. The mother's hands, bedclothes, and nightgown must be kept clean, and the clothes must be boiled every time they are washed.

For at least 2 weeks after birth the baby's eyes should be watched daily for any signs of irritation. If there is a discharge or a collection of

“matter” in the corner of one eye or on the lid or eyelashes, the town, county, or State department of health must be notified at once. This, too, is usually required by law. In most States the presence of any discharge from the eye of the newborn must be reported immediately to the board of health, and every effort possible be made to get a doctor at once. “At once” means without losing one minute.

While waiting for the doctor the midwife should keep the baby from touching his eyes with his hands, and she should not touch anything but the baby until she has scrubbed her hands. Otherwise she might transfer the germs from the baby's eyes to her own or to another's eyes. She might send someone for the town or county nurse to help in making the plans for caring for the mother and the baby so as to protect the rest of the family.

Because good doctors and midwives give all this careful attention to babies' eyes, fewer children now are blind because they had “babies' sore eyes.”

After the midwives have had a chance to ask questions about this general explanation, show them exactly how to care for the baby's eyes, as follows:

- A.* Arrange the things on the table so that they are convenient to use.
- B.* Put the baby bed with the head toward the light so that the doll is looking away from the light. This will give the midwife light to see what she is doing and at the same time keep the baby from screwing his eyes tight shut as he would if he were looking toward the light.
- C.* Turn the doll on its back.
- D.* Scrub the hands thoroughly. Emphasize the importance of clean hands, which can carry no infection to the baby's eyes.
- E.* Warm one ampule of silver-nitrate solution by holding it in the hand for a few moments.
- F.* Open the ampule by sticking the needle in the top.
- G.* With the ampule held between the thumb and the first two fingers of the right hand, squeeze out one drop of the solution over the newspaper bag.
- H.* Then, standing so that you face the doll, go through the motions of opening the doll's right eye by laying the thumb of the left hand on the cheekbone and the first finger on the eyebrow and separating the thumb and the finger. This will open the eyelids of a baby without pressing on the eyeball and without digging the fingers into the flesh or letting them slip on the skin (fig. 46).
- I.* With the ampule in the right hand, squeeze two drops of solution into the eye.
- J.* Remove the finger and thumb to let the baby's eye close and then catch the overflow with a clean cotton ball so that it will not run onto the blanket and stain it.

- K.* Wait a few minutes and shade the doll's eyes. You would wait for the baby to open his eyes of his own accord. If you did not do this, he might keep his left eye shut so tight that it would be difficult to open it.
- L.* In the same way put two drops in the left eye.

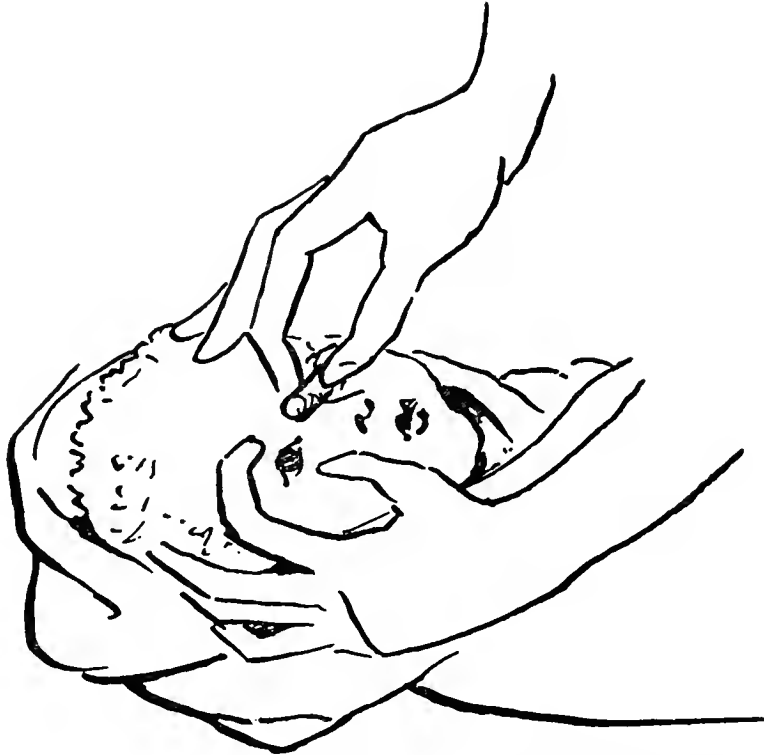

Fig. 46.—PUTTING DROPS IN THE BABY'S EYES.

Let each midwife practice doing this, using the doll so that she can learn to use her hands correctly. Try the opening of the eyelids on the midwife herself to let her see how it is done gently and without pressure. Scrub your hands after demonstration to each midwife in order to emphasize how important it is to protect every eye from the possibility of transferring a germ to another even when there is no inflammation. Have the midwife scrub her hands and open your eye to be sure she has learned to do it gently. Be on the watch for the midwife who "digs in" with her fingertips instead of just laying them on the surface and separating the fingers without letting them slip on the skin. Be sure that every midwife before she leaves learns to put the drops in the baby's eyes properly.

## Lesson XII.

# The Midwife's Management During the First Stage of Labor

## A DEMONSTRATION

### TEN-MINUTE REVIEW

What happens during the first stage of labor?

What happens during the second stage of labor?

What happens during the third stage of labor?

What three things must we keep especially in mind during labor?

What are the "powers" during the first stage of labor?

Why is it harmful to bear down during the first stage of labor?

Give two reasons.

How can we keep up the mother's power and strength to assist in her delivery? Give two ways.

What do we mean by "the passage"?

Why do we need a doctor to determine its size and shape?

What is a germ?

Who are responsible for keeping disease germs away from the birth canal?

What must each one do?

Why is it dangerous for a midwife to put fingers or anything else into the birth canal?

How does she prepare her hands for the delivery of the baby?

Why does the midwife wear a mask?

How long can we expect the first stage of labor to last?

How long can we expect the second stage of labor to last?

How long can we expect the third stage of labor to last?

### Foreword

When the midwife understands the **processes** of labor, the most practical way to teach her the **management** of labor is to present it as a 3-act play or demonstration. The supervisor takes the part of a midwife and makes the whole performance as realistic as possible with dolls to represent the mother and the baby. She describes in detail any procedures that cannot be acted.

## Purpose

To show the midwife how she should manage during the first stage of labor—

- A. To prepare for a safe and clean delivery in order to protect the mother and the baby from injury or infection.
- B. To watch for signs of danger in order to get medical assistance if there is the slightest sign that all is not going well.
- C. To guide the mother's activity in order to conserve her strength.
- D. To keep up the mother's nutrition and fluid intake in order to provide energy, keep up morale, and make for ready elimination.

## Equipment

A bedroom and a kitchen arranged as for a delivery with the following furniture and supplies:

### In the kitchen (fig. 47, p. 94) :

Stove or makeshift to represent a stove with a large teakettle with a lid, two cooking kettles with handles and lids, a long-handled dipper in the larger kettle, and irons, bricks, or bags of sand for warming the beds.

Three chairs.

Large kitchen table with four basins (two of them the same size), a 1-quart water pitcher, one cup, four saucers, two teaspoons, two plates, a can of milk, a jar of sugar, a can of cocoa, a pair of ordinary household scissors, a jar of lard. Nearby is a bucket of clean water.

Baby tray with five covered glass jars, one pint bottle (with top) for baby's boiled water, one nursing bottle, two nipples, one cap for the nursing bottle, six large and six small safety pins, two cakes of soap, 1 pint of mineral oil, one soap dish (a saucer with a cup turned upside down), one new box of grade-A absorbent cotton. (See pp. 50, 53, 94 and fig. 32, p. 49.)

On the floor under the table a laundry tub clean and empty and an uncovered bucket for dirty water.

### In the bedroom (fig. 48, p. 95) :

One bedstead with springs, mattress, and a table leaf or board (see p. 4) to use for reinforcing the mattress. The bed should be made up for sleeping with a clean blanket and a quilt on it.

Two bedside tables.

Dresser.

Three bedroom chairs.

Lamp.

Toilet bucket or slop jar with cover.

In one dresser drawer a bag of clean white rags of various sizes, two cakes of soap, two clean washcloths, four clean towels, four clean sheets, four clean pillowcases, two clean nightgowns, two pairs of clean stockings, one blanket, one toothbrush, one comb, a large bundle of newspapers, six newspaper pads, four sanitary pads, one new roll of toilet paper, a

bedpan or a bakepan and a smooth board covered with a newspaper and placed across one end of the pan.

In another dresser drawer, one baby shirt, one band with three small safety pins attached, six diapers, one dress, one flannelette square, two washcloths, two towels, and one baby doll with string to serve as a cord attached to its abdomen with adhesive.

Baby bed with mattress and mattress pad, pillowcase, three baby blankets, and mosquito netting.

Adult-size doll dressed in nightgown, kimono, stockings, and house slippers and sitting on a chair.

Midwife's standard equipment in perfect condition with the apron and cap to fit the nurse who is demonstrating.

### Procedure

Explain that you are going to act the part of a midwife attending a woman in labor. Leave the room and enter with your hat and coat on and carrying your bag and a newspaper.

Greet the mother cheerfully, put your hat and coat on the back of a nearby chair and your bag on the newspaper spread on the seat of the chair. Wash your hands, using the family soap and basin. Watch the mother's expression, feel her abdomen during two or three pains, and inquire about her condition with some such questions as these:

When did your pains begin?

Have you had any rest?

Where are the pains, in your back or in your abdomen?

How often do they come?

How long do they last?

Have you any pain or soreness in your abdomen between the labor pains?

Is there any watery or bloody discharge from the birth canal?

Is there any bleeding?

Has the bag of waters broken?

Do you feel like bearing down?

Do you feel the baby moving?

When did your bowels move?

Are you constipated?

When did you pass water?

When did you eat last?

What did you eat?

Have you vomited?

Have you a cold, sore throat, bad headache, cough, chills, fever, shortness of breath, any swelling, fits, or any other discomfort or misery?

Explain that the answers to these questions and the mother's expression and behavior during a pain or two if she has any would give the midwife an idea whether or not the mother is in labor and whether she

has had any of the danger signals. If there is the slightest suggestion of a danger signal or if the baby is not yet due and the mother is having real pains, the midwife should call a doctor.

Suppose that there are no signals of danger and that there are labor contractions which you can feel when you put your hand on the mother's abdomen, so that there is no time to lose in getting ready.

**First things to do:**

- A. See that the fire in the kitchen stove is burning well. Put plenty of water on to boil in the large teakettle and the large covered cook kettle with a dipper in it. Put irons on stove. Explain to the family the need of a fire for warmth, for a good supply of hot boiled water, and for keeping the irons hot.
- B. Cover the kitchen table with clean newspapers.
- C. Wash your hands again.
- D. Open your bag and take out the equipment.
- E. Put on the cap, tucking your hair well inside.
- F. Put on the mask, making certain that it covers your mouth and your nose.
- G. Wash your hands again.
- H. Arrange the rest of the equipment on the table so that you can get it easily.
- I. Close your bag and put it out of the way.
- J. Put in one of the basins 30 to 35 wipes (large swabs of grade-B absorbent cotton or pieces of clean white rags about 4 inches square), cover them with boiling water, invert a second basin over it to use as a cover, and put them on to boil. Let them boil for 10 minutes after the water begins to bubble.
- K. Place the cord scissors in the sterilizing pan from your bag, cover them with boiling water, put on the lid, and let them boil for 10 minutes.
- L. Place the mother's household scissors in a stewpan, cover them with boiling water, put on the lid, and let them boil for 10 minutes.

**The mother's bath.**—Assume that the mother has not bathed and prepare a basin of warm water, a cake of soap on a saucer, a clean towel, a washcloth, stockings, and a nightdress. Explain that the mother can take an all-over sponge bath, put on the clean clothes, and comb her hair (fastening the braids if her hair is long) while the midwife is making the delivery bed. Show how the midwife can help the mother wash her feet and her back because they are hard for her to reach, and can put newspapers on the floor for her to step on if she has no bedroom slippers. Empty, wash, rinse, and scald the basin. Rinse the soap and soap dish and put them away with the mother's washcloth and towel for her use later.

**Making the delivery bed.**—Make a delivery bed and the newspaper pans and bags as directed in lessons IV and VI (pp. 42 and 55).



**Arranging the supplies at the bedside.**

- A. Cover two chairs, one table, and the dresser top with several thicknesses of newspaper and arrange those things from the dresser drawer that you will need during labor and delivery where they can be easily reached as you need them.
- B. Place on newspapers on the floor near the bed the toilet bucket with the rim protected with folded newspapers and the lid or a newspaper cover near it.
- C. After the water has boiled for 10 minutes, set everything off the stove to cool except the big kettle of boiling water.
- D. Drain the water off the cord scissors, taking care not to remove the lid nor drop the scissors. If anything should touch the scissors, boil them again. Place on the bedside table the covered pan with the boiled untouched scissors in it. Explain why the scissors must be kept sterile.
- E. Drain the water off the household scissors and let them dry.
- F. Place the basin of boiled wipes, still covered, on the bedside table and a clean cake of soap in a saucer beside it.
- G. Place nearby the packages of cord dressing and clean apron, all unopened.
- H. Prepare a receiving blanket for the baby by putting one large piece of the clean old muslin inside a clean baby blanket and wrapping them around a warm flatiron. Put it within easy reach on the bedside table.
- I. Beside it in the following order put a large piece of the clean old muslin, a baby binder with three safety pins attached, and two sanitary pads in their covers.

**Making a hand-scrub table** to use for the final hand scrub just before the baby is born.—Use a chair covered with newspapers for a table and place it where you can watch the mother while scrubbing. Place on it a clean empty basin and a saucer with your soap, hand brush, and nail stick on it. Nearby on the floor put several newspapers and on them the tea-kettle of boiled water.

**Preparing the vulva for the delivery.**—Explain that the vulva should always be prepared before an enema is given because if the enema should stimulate hard pains there might not be enough time to do it thoroughly afterward. Wash your hands thoroughly so that you will not run any risk of transferring germs to the mother. While you are arranging, on a newspaper-covered chair near the bed, a clean basin of warm water, the mother's soap in a dish, the family scissors, boiled and dried, and 18 or 20 clean dry wipes, explain that you would have the mother pass water and empty the bowels if possible before lying down on the bed. If she is unable to pass water easily, she should drink two glasses of water or of some sweet sugary drink.

The mother (the doll) is lying on her back with the newspaper pan under her buttocks and is covered with the draping sheet and blankets. Show how to clip the vulval hair as close as possible, using the family scissors and throwing away the waste in the newspaper bag. Then wash, rinse, and dry the abdomen, thighs, vulva, buttocks, and the anus as described in lesson X (p. 82) after the enema. Explain that while you are preparing the vulva you have an excellent opportunity to watch the mother during pains and decide how fast the labor is progressing.

**The enema.**—This is the time to decide about the enema. Go over the reasons for deciding whether or not to give an enema. Give an enema as described in lesson X (p. 79). Explain why the washing must be repeated after the enema and again if the bowels move again before the final washing with the boiled wipes that is demonstrated in lesson XIII. After that the area is kept clean with the boiled wipes. Explain that after the mother has rested a few minutes she could put on shoes or house slippers and walk about a while in her bedroom unless the second stage seems to have begun or the bag of waters has broken and there is some leaking.

**Watching the progress of labor.**—Explain that all this time and during the whole of labor you keep careful watch of the mother, note the frequency of the pains, their duration, their character, do not let the mother bear down during the first stage of labor, look for bulging during a pain every few pains so that you will know as soon as the second stage of labor begins. Watch for bleeding, discharge, odor, sores about the vulva. Explain how each of these is dangerous for the midwife, the mother, and the baby.

If the midwife notices anything abnormal, if the mother cannot obtain relief although she complains of a full bladder, or if she passes water only infrequently although she has taken plenty of fluid, the midwife should send for a doctor at once. If the mother has had six glasses of fluid since she passed water last, she should have no more until the doctor prescribes for her.

Explain to the mother about "bearing down" and later "panting like a dog." Tell her why she cannot help herself by bearing down in the first stage of labor. Tell her how much she can help when you give her the signal if she will do it just as you show her how to and stop when you say "Pant."

**Nourishment.**—Explain that mothers often refuse nourishment during labor because of nausea—feeling sick at the stomach—but that the mother in labor will surely find her spirits sinking when her stomach is empty. Prepare a cup of cocoa so that the midwife can see it as

part of her care of the mother and urge the mother to keep up her strength by drinking nourishing fluids. Explain that the midwife might substitute for the cocoa, lemonade, orangeade, fruit juice, hot milk or coffee. Explain that the midwife should see that the mother takes some nourishing fluid every 2 hours. Loss of blood at the time of delivery and afterward is more serious and harder to control if the mother is weakened by lack of nourishment.

**Rest.**—Explain why periods of rest are necessary, especially if the mother is having a long first stage of labor with little or no sleep. Alternate periods of rest and activity divert the mother's attention from herself, help the time to pass more quickly, and allow a freedom that is satisfying. Mothers are more content when allowed to walk about the room if there is nothing in their condition to make this a risk.

Describe the mother who complains of pains in the small of her back and rub her back with each pain. While the mother is resting or walking about, the midwife can see that everything is ready for the second stage of labor, looking and listening constantly in order to notice anything abnormal about the mother's condition and to know just when the second stage of labor begins.

**Encouraging the mother.**—Tell how encouragement, reassurance, and a quiet attitude on the part of the midwife and the family help to relieve the mother's mind of fear and anxiety and how that is an important factor in her care. Labor progresses better if the mother keeps up her courage and her spirits. A pat of the hand and a bit of praise after a hard pain will help. Telling the mother about the progress she is making will also help, and keeping up her strength with nourishing drink will do a great deal for her courage, too.

**The baby's things.**—Make the baby's bed between times, protecting the mattress with an oilcloth or rubber pad and slipping the mattress and pad into a pillowcase. Raise the foot by putting a roll of newspapers under that end of the mattress. Put a folded newspaper covered with one of the clean white rags at the head of the baby's bed for his head to rest against. Wrap the baby blankets about a warm flatiron and place them in the baby's bed to warm it. Tie together with a strong rope the two chairs in the bedroom and put the baby bed on these chairs near the delivery bed. Explain everything you do as you work.

Assume that there is time, before the second stage begins, to prepare the baby tray and that the mother has not already done this. (See lesson V, p. 53.) Put the box of silver nitrate on the tray.

Get everything ready to put the drops in the baby's eyes where the light is good (see lesson XI, p. 83) and to oil the baby near the kitchen stove (fig. 47).

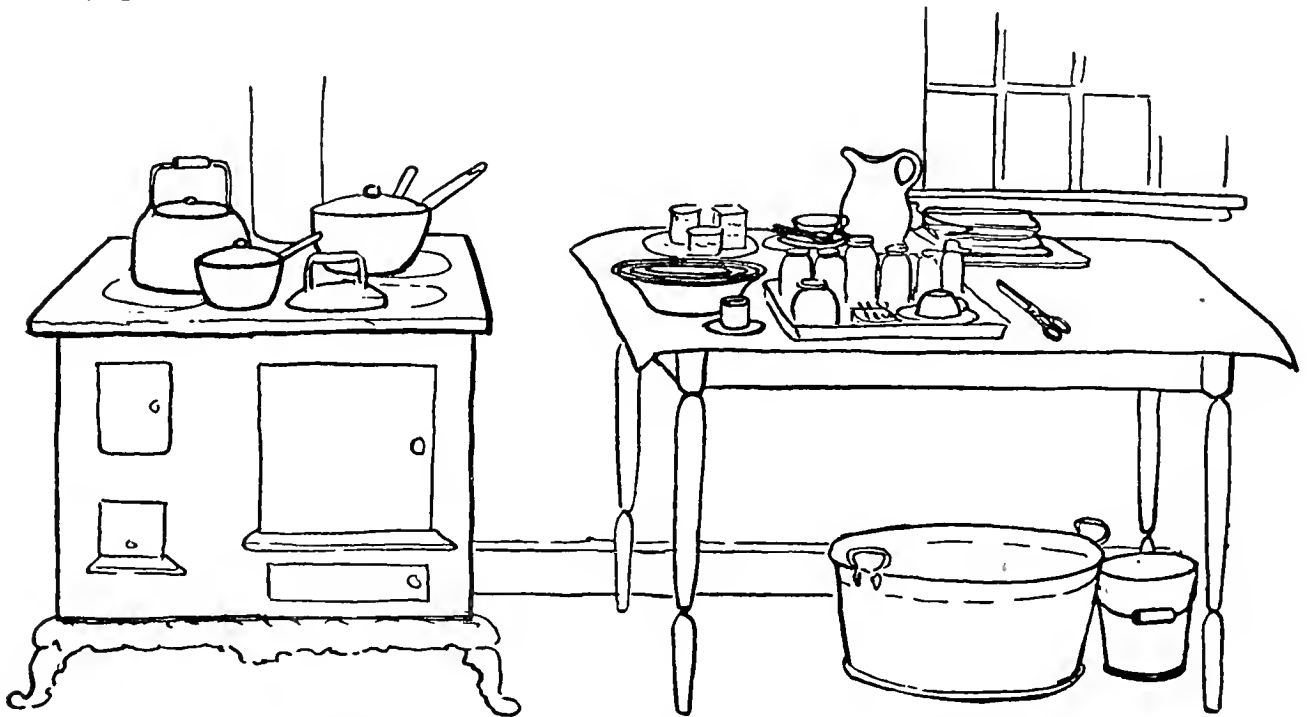
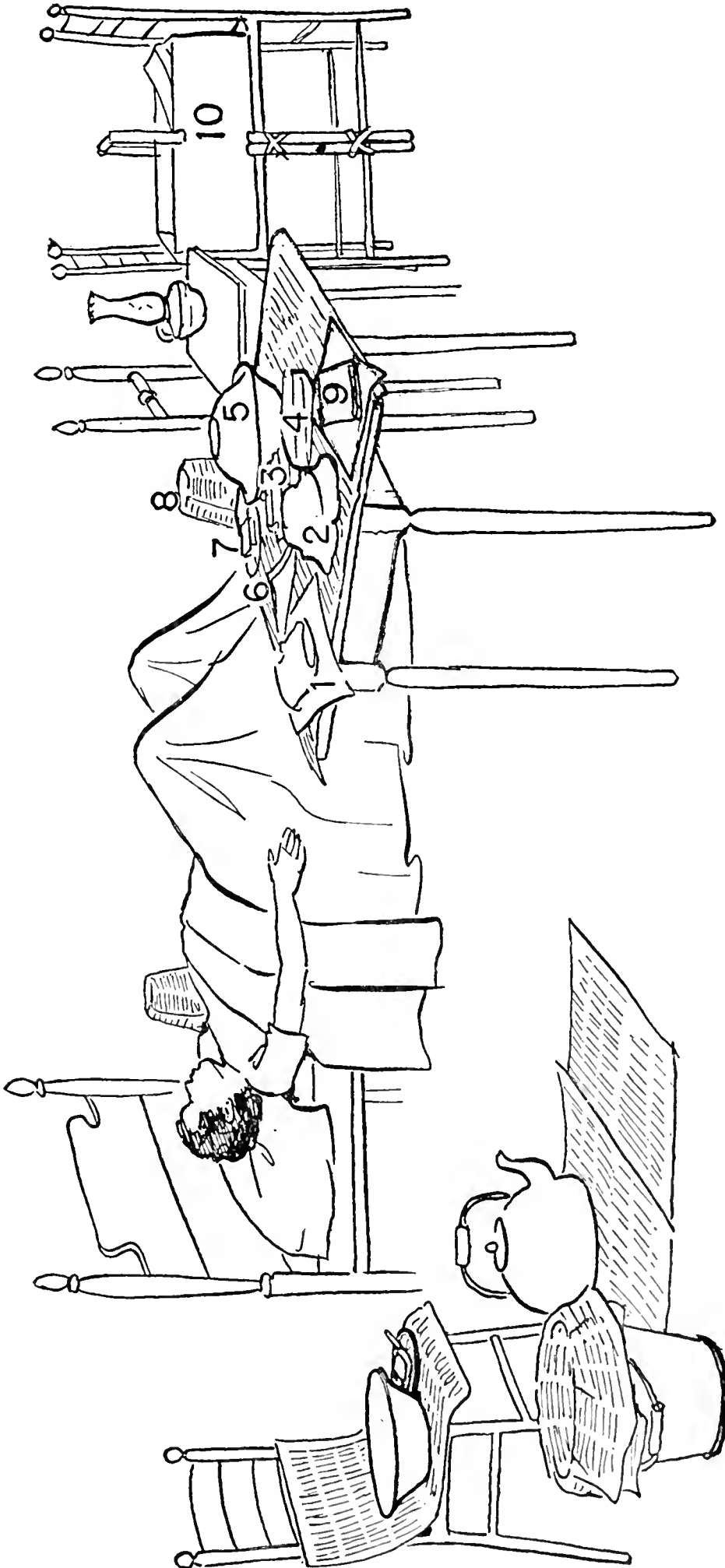

Fig. 47.—EQUIPMENT IN KITCHEN FOR SECOND STAGE OF LABOR.

- A. Arrange the kitchen table (see p. 88), leaving a place on the table for the baby bed.
- B. Set the baby tray where you can reach it, but leave the covers on the jars until you are ready to oil the baby.
- C. Put nearby the baby clothes, washcloth, and towel rolled in a flannelette square with a warm iron.
- D. Measure out about half a cup of the oil and set the cup in the pan of hot water on the back of the stove to keep warm. Assume that the supply of oil is not in a new unopened bottle, and put all the oil in a clean saucepan and boil it in order to kill any germs that might be in it. Be sure to warn the midwives about using it too warm. It must be cooled to blood heat before it can be used. Explain that the oil should be neither hot nor cold but warm enough not to chill the baby.
- E. From the teakettle fill the jar on the baby's tray for the boiled water for washing the mother's nipples and the pint bottle or jar for the day's supply of boiled water for the baby.

**Symptoms of approaching second stage of labor.**—After everything is ready, watch and wait for the signs of the second stage of labor:

- A. The pains will become more regular and more frequent, will be harder, and will last longer.
- B. The mother will complain more of discomfort; her voice will become high pitched.



1. Baby binder and 3 safetypins.
2. Clean receiving blanket wrapped around a warm flatiron, and large piece of clean, old muslin.
3. Covered sterilizing pan (has boiled cord scissors in it).
4. Sanitary pads.

5. Boiled absorbent-cotton or rag wipes in basin.
6. Card dressing.
7. Saucer and soap.
8. Newspaper bag.
9. Midwife's apron.
10. Baby's bed.

Fig. 48.—EQUIPMENT IN BEDROOM FOR SECOND STAGE OF LABOR.

- C.* The mother will vomit or feel as if she were going to.
- D.* The mother will involuntarily push or bear down or grunt when she has a pain, and say she can't help it.
- E.* The mother will feel that her bowels are about to move or will complain of pain in her rectum.
- F.* The anus will open with each pain.
- G.* A small amount of bright red "show" will appear at the vulva—a trickle of blood.
- H.* The bag of waters may break.
- I.* The vulva will bulge and open with each contraction.

Explain that the mother should go to bed when these signs appear if it is a first baby. If she has had a baby before, she should go to bed when the pains are hard and coming every 2 or 3 minutes. The midwife sees that the bed is dry and clean and that a dry clean newspaper pad and the lined thick newspaper pan are in place. Help the mother to take off her kimono, house slippers, and stockings, and put on the clean stockings. Help her into bed, see that the paper pan and pad are under her buttocks, and cover her with the draping sheet and blanket (fig. 48). Then the midwife must hasten to scrub her hands and arms and get ready for the baby's birth. Another lesson will go on from here through the second stage of labor.

### SUMMARY

Remember that a properly managed first stage of labor usually means less trouble and less complication in the second and third stages. Do the first things first: learn the mother's condition, make sure about having a good fire, plenty of hot and cool boiled water, your things where you can get them, the sterile wipes and scissors in the mother's room, the mother, her room, her bed, and the supplies clean and ready, and the baby's things ready to keep him warm and to protect him from infection. Make it your constant care to watch the mother, encourage her, keep her warm, clean, protected from infection, fed, and rested. Do not let the baby arrive before you are ready for him because you failed to recognize the signs of the second stage of labor in time. And, above all, keep your eyes and ears open for danger signals and get a doctor if you have the slightest reason to think all is not as it should be.

## The Midwife's Management During the Second Stage of Labor

### A DEMONSTRATION

### TEN-MINUTE REVIEW

What happens during the first stage of labor?

What three things must we keep in mind as we prepare for the delivery?

What should we ask about, as soon as we arrive in a home where a mother is in labor?

What will you do to protect the mother from infection?

What danger signals should we look for in the first stage of labor?

What would you do if you found bleeding, fits, exhaustion?

What would you do if the mother had strong labor pains for 12 hours and you could see no signs of the second stage of labor?

How will you know when the second stage of labor is about to begin?

### Purpose

To show the midwife how to manage during the second stage of labor so that—

*A.* She can help the mother—

1. To use each pain to advantage.
2. To rest between pains.

*B.* She can protect the mother—

1. From infection.
2. From injury.
3. From chilling.
4. From unnecessary fatigue.

*C.* She can call a doctor if there are signals of danger.

*D.* She can care for the baby when he is being born and immediately afterward—

1. To make sure he is coming normally; or, if not, to call a doctor.
2. To protect the cord and eyes from infection.
3. To tie and cut the cord properly.
4. To keep him warm.
5. To watch his color and his breathing.
6. To watch the binder for any sign of bleeding from the cord.

*E.* She can watch the mother while she cares for the baby.

### Equipment

Everything is as it was at the close of lesson XI (p. 86), the supervisor wearing a mask and a cap.

### Procedure

Explain that we left the mother in bed lying on her back, covered with a clean sheet and a blanket. Turn down this sheet to slightly below the waist. Fold the blanket in two crosswise and place it on the mother's chest and turn it up to about the hip line. See that the newspaper pads and a thick newspaper pan lined with a piece of clean old muslin are under the buttocks and that the pads extend well down toward the feet. The bag of waters may break at any time now if it has not done so before.

**"Pushing" and "panting."**—Explain to the mother that the time has now come when she must use her abdominal muscles to help push out

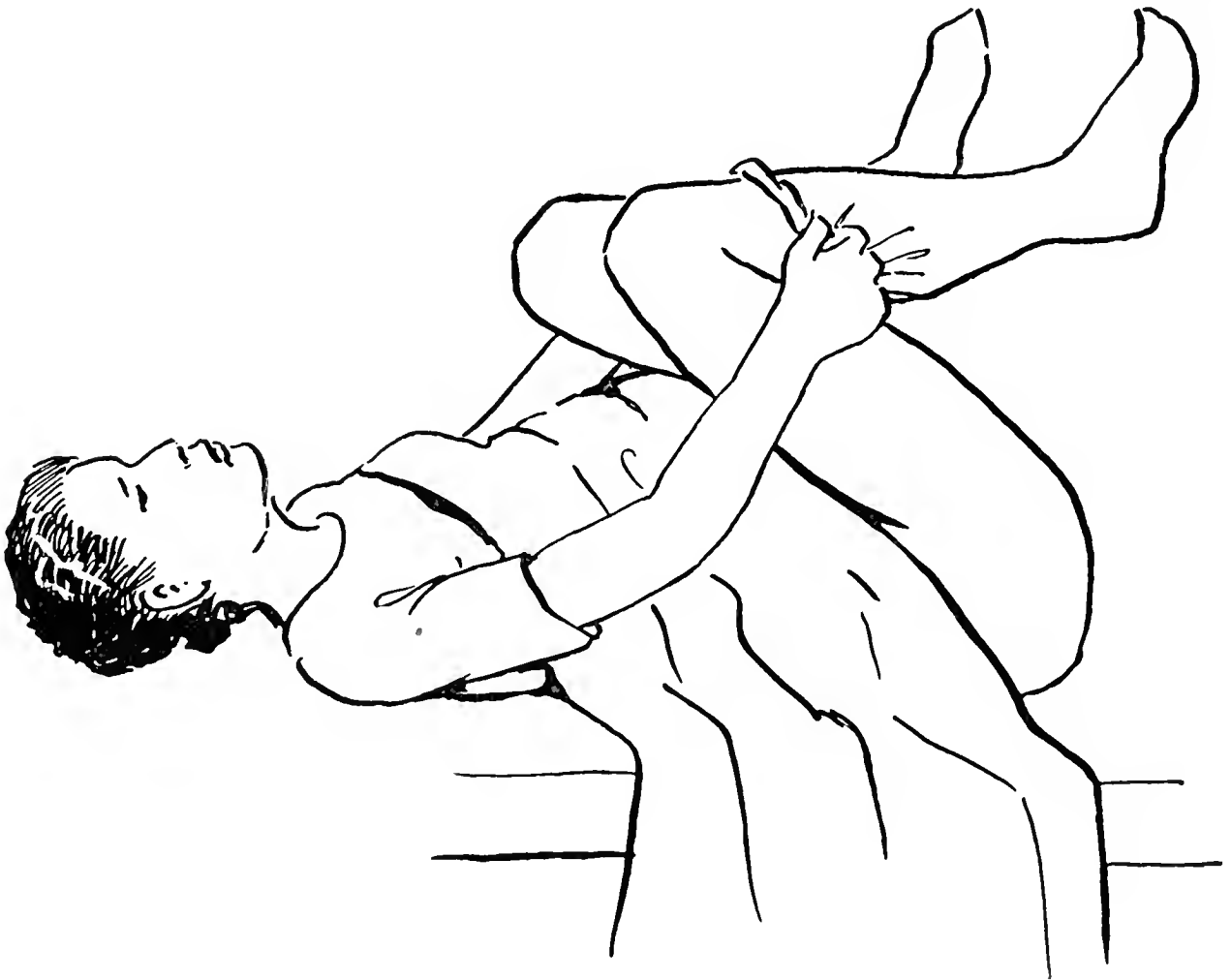

Fig. 49.—MOTHER "PUSHING."

the baby. Describe how when the pain begins you would have her take a good breath, close her lips tight, and bear down as she might when she is having a bowel movement. Show her how she can draw up her legs against her abdomen with her knees bent and grasp the tops of her



stockings at the knees and pull on them during a pain to make her pushing more effective (fig. 49). She should push only when the uterus is contracting during a pain. Pushing between contractions will waste her strength and wear her out. Show how she can be helped to stretch her legs and relax between the pains.

Explain to the mother that later when you tell her to “pant” she must open her mouth and “pant like a dog” even though she has a strong urge to bear down. This cooperation on the part of the mother will make it possible for the midwife to delay the delivery of the head during the greatest force of the contraction, so as to avoid tearing the mother as the head comes through the vulva.

**Staying with the mother.**—Explain why the midwife should not leave the bedside of the mother again. If possible, a member of the family should stay in or near the room in case the midwife should need any help. Show how you would look at the vulva with every pain to see if there is any bleeding or if any part of the baby is in sight. Explain that if a hand or foot or cord should appear, you would send for a doctor at once. In such an emergency the midwife should not touch the baby or the birth canal. If the mother should become exhausted, pale, or cold, if the pains

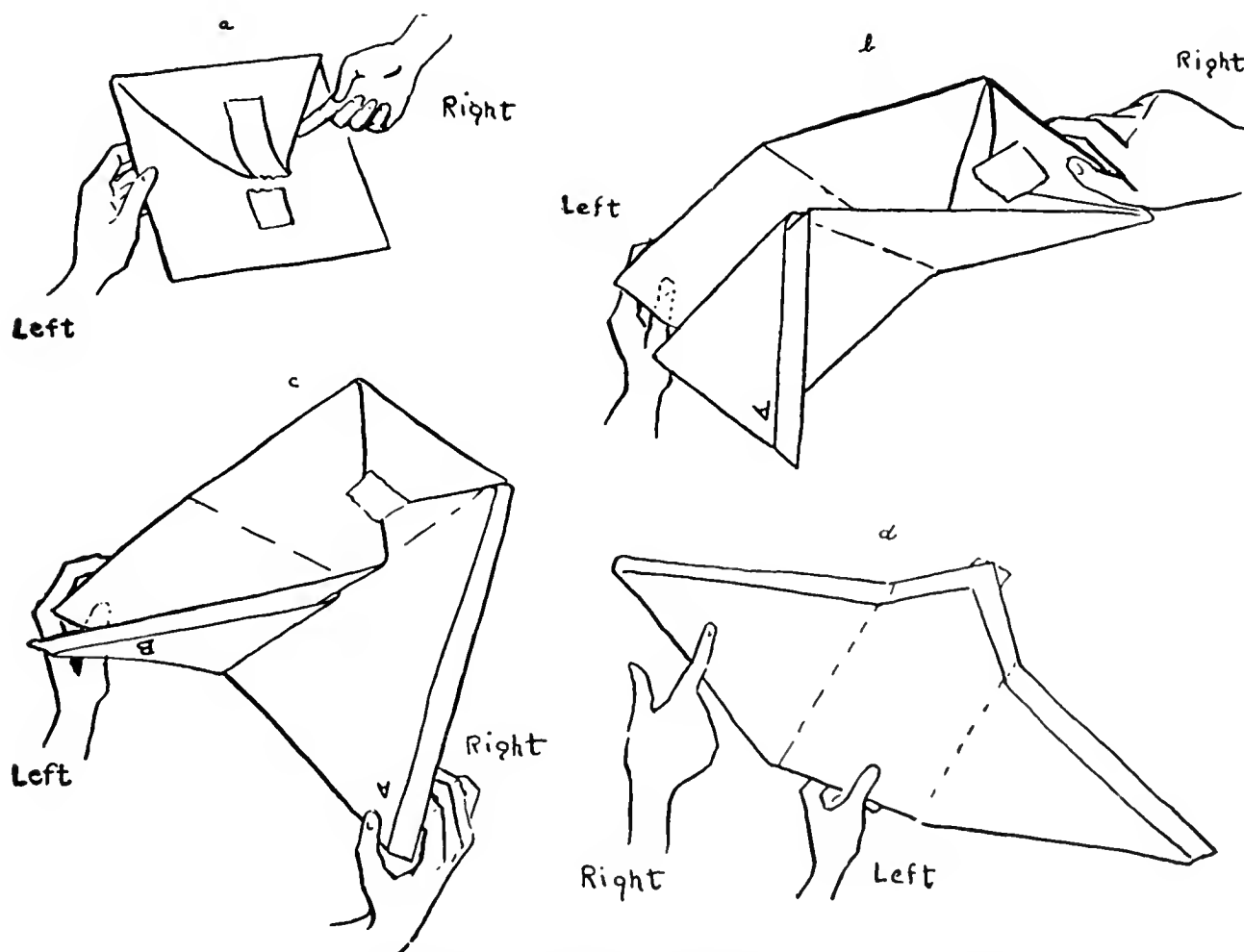
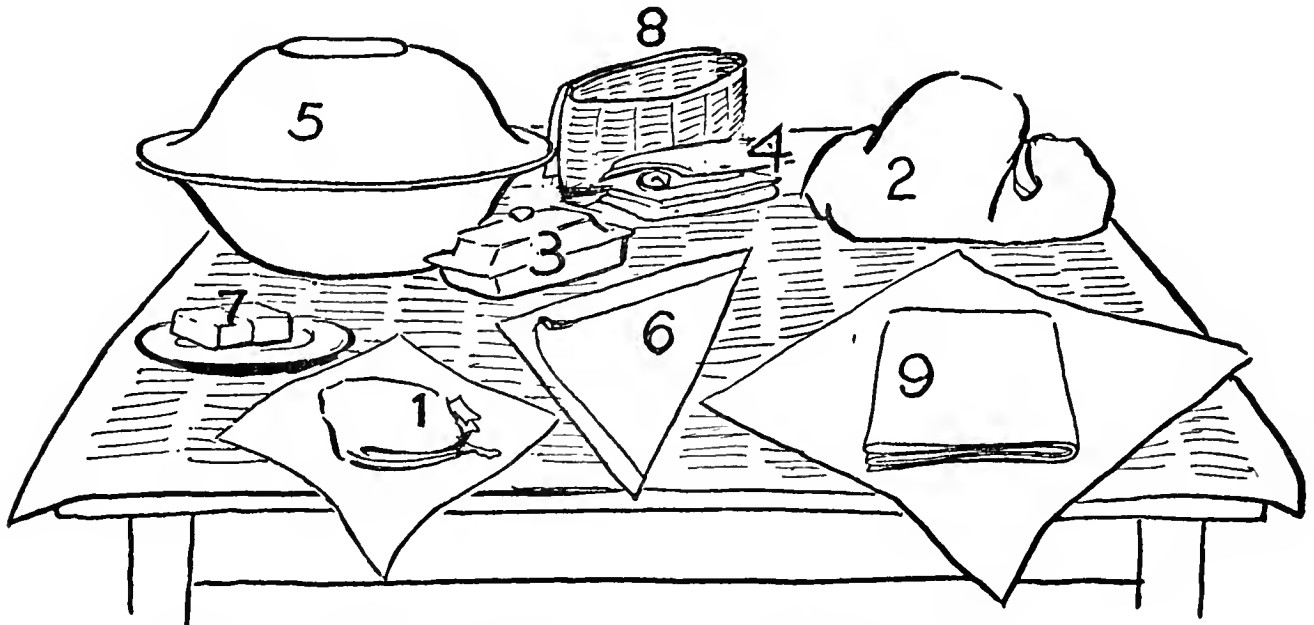

Fig. 50.—OPENING STERILE PACKAGE. FOUR VIEWS.

stop, if she bleeds, if she has a sharp abdominal pain or any other symptom of trouble, the midwife should send for a doctor at once.

**All the supplies within reach.**—See that the supplies can be reached from the bedside. Then break the seal of the package of sterile cord ties and dressing and open it half way, leaving the upper flap still covering the sterile supplies (fig. 50, four views). Open the package containing the clean midwife apron without touching the apron (fig. 51).



- |   |   |
|---|---|
| 1. Baby binder and 3 safety pins.   | 4. Sanitary pads.                                 |
| 2. Clean receiving blanket (a baby blanket lined with a large piece of clean, old muslin) wrapped around a warm flatiron, and another large piece of clean, old muslin. | 5. Boiled absorbent-cotton or rag wipes in basin. |
| 3. Covered sterilizing pan (has boiled cord scissors in it).  | 6. Cord dressing.                                 |
|   | 7. Saucer and soap.                               |
|   | 8. Newspaper bag.                                 |
|   | 9. Midwife's apron.                               |

Fig. 51.—SUPPLIES ON TABLE IN DELIVERY ROOM.

**The midwife's final scrub up.**—This is the time for the midwife to scrub her hands thoroughly in preparation for the baby's birth. Review the technique of lesson VIII (p. 62) as you scrub your hands. Keep one eye on the mother as you scrub. Rinse the basin, scald it, put your soap in it, and fill it with warm boiled water for your later use.

Assuming that the baby is coming soon, put on the clean midwife apron.

**Draping with the sheet.**—Drape the mother with the large sheet that is over her legs. This draping is done by pulling the sheet cornerwise. The upper corner is folded under itself and the sheet is tucked under the mother's back near the waist. The outer corners are used to cover each leg. No effort is made to cover the feet as the mother has on clean stockings. This sheet should be so arranged that it will not get in the way during the birth of the baby.

**Washing the vulva with the boiled wipes.**—Remove the basin which has been covering the boiled cotton or rag wipes and place it on the far corner of the mother's bed for use later. Wash your hands, digging your nails into the soap. Do not dry them. Pick off the top wipe. Wring it as dry as you can over the hand-scrub basin. Soap it well, using the clean soap in the dish beside the basin, and wash the mother thoroughly, using one wipe for the abdomen, one for each thigh, another for the vulva, and another to wash about the buttocks and the anus. Drop the soiled wipes into the paper bag. Use fresh wipes to rinse the parts and discard each one in the same way. Leave the basin of boiled wipes where you can reach it easily. Show how you would use them to wipe away feces if the mother's bowels should move with the pains, wiping **from** the birth canal, never toward it, and using a fresh wipe for each down stroke.

**Keep the bed dry.**—Explain how if the lined newspaper pan under the mother should become wet you would replace it with a clean, dry one, pushing the wet one under the bed or into the toilet bucket.

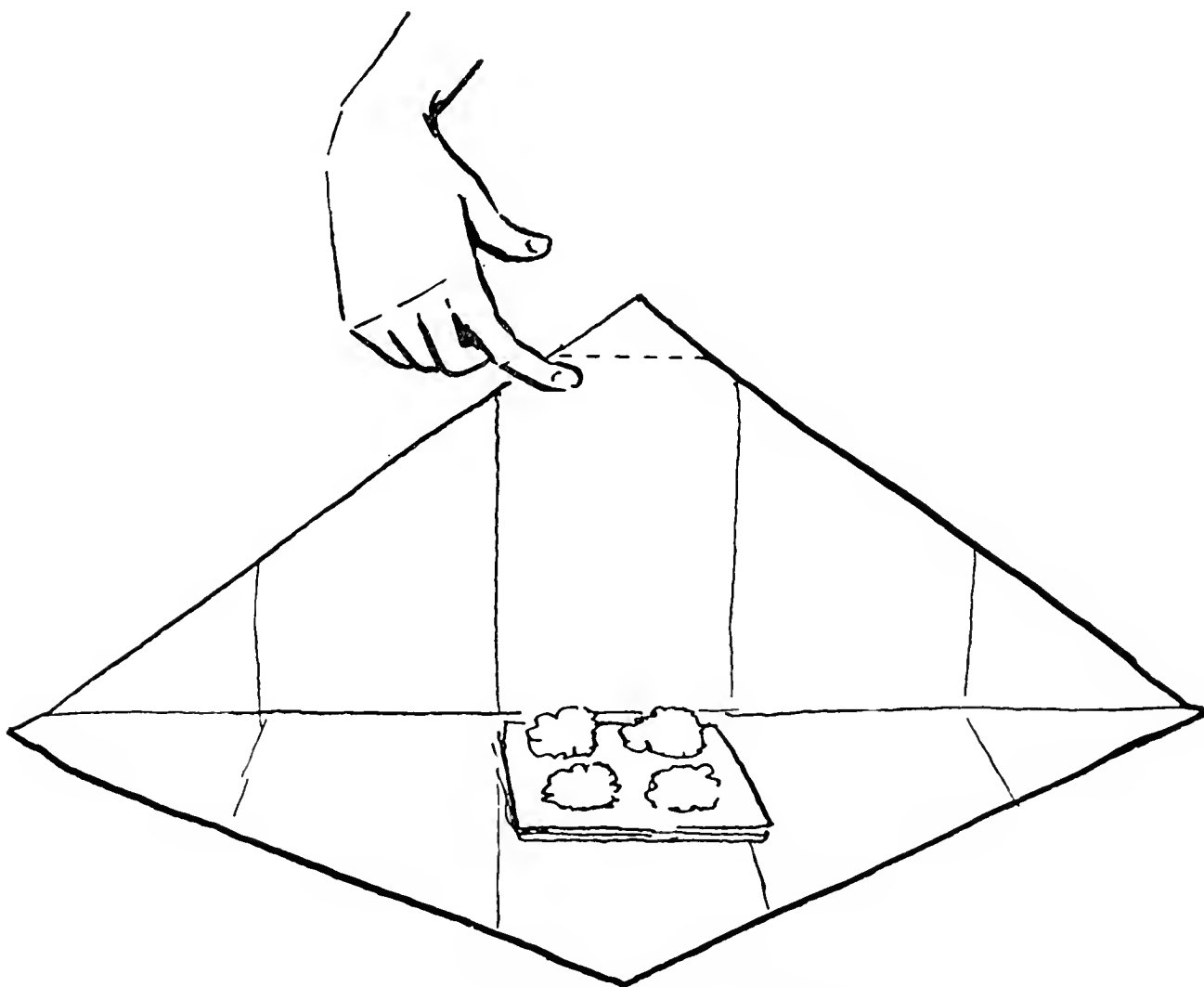

Fig. 52.—OPENING STERILE PACKAGE.

Or, if the bag of waters has broken, you would leave the mother on a clean, dry pad without a pan. The baby can be born on the clean, muslin-covered newspaper pad.

**When the baby's hair is in sight.**—Describe how the birth canal begins to open up and the baby's hair can be seen, then spread the large piece of clean old muslin (that you left near the receiving blanket—see p. 91) between the mother's flexed legs, so as to have a clean, dry place to lay the baby, after he is breathing well, while you tie and cut the cord. Wash your hands again quickly, keeping an eye on the vulva.

Stand ready, watch, and wait. Describe the mother's face as covered with sweat and ask a member of the family to sponge her face, wrists, and hands and dry them with a clean towel. Open wide the sterile package (fig. 52).

**When the head is being born.**—Describe the descent of the head with each contraction and speak of the difference one would expect when a mother is having her first baby and when she is having later ones.

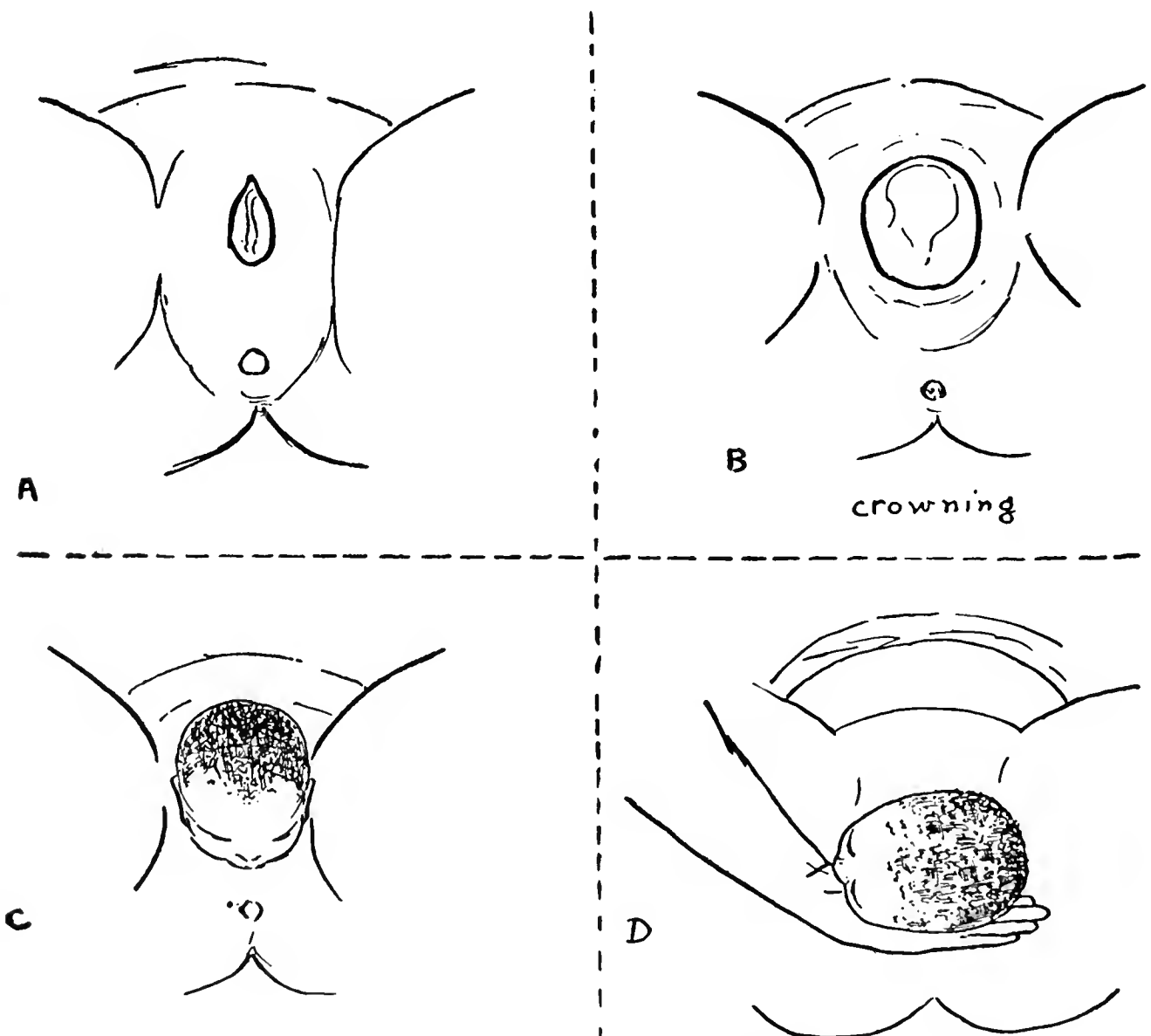

Fig. 53.—BIRTH OF THE HEAD. FOUR VIEWS.

Point out how the midwife would have the mother push. Show the position of the mother—legs flexed on the abdomen, hands grasping stockings just below the knees. The mother can remain in this position until the baby's head "crowns" at the vulva. Then she should lower her feet to the bed with her knees flexed and "pant" so that she will stop pushing during the expulsive pain. Then describe the pain as passed and tell her to "bear down" gently so that the baby's head will be born. As if the baby's head were being born, show how to support it with the left hand while with the right hand you wipe away the mucus from the eyelids, nose, and mouth, using the clean cotton balls from the sterile package (fig. 53, four views).

Explain that about one baby in four has one or more loops of cord around his neck. The midwife should feel for the cord around the baby's neck as soon as the head is born and push the cord down over his shoulders or slip it over his head, whichever is easier.

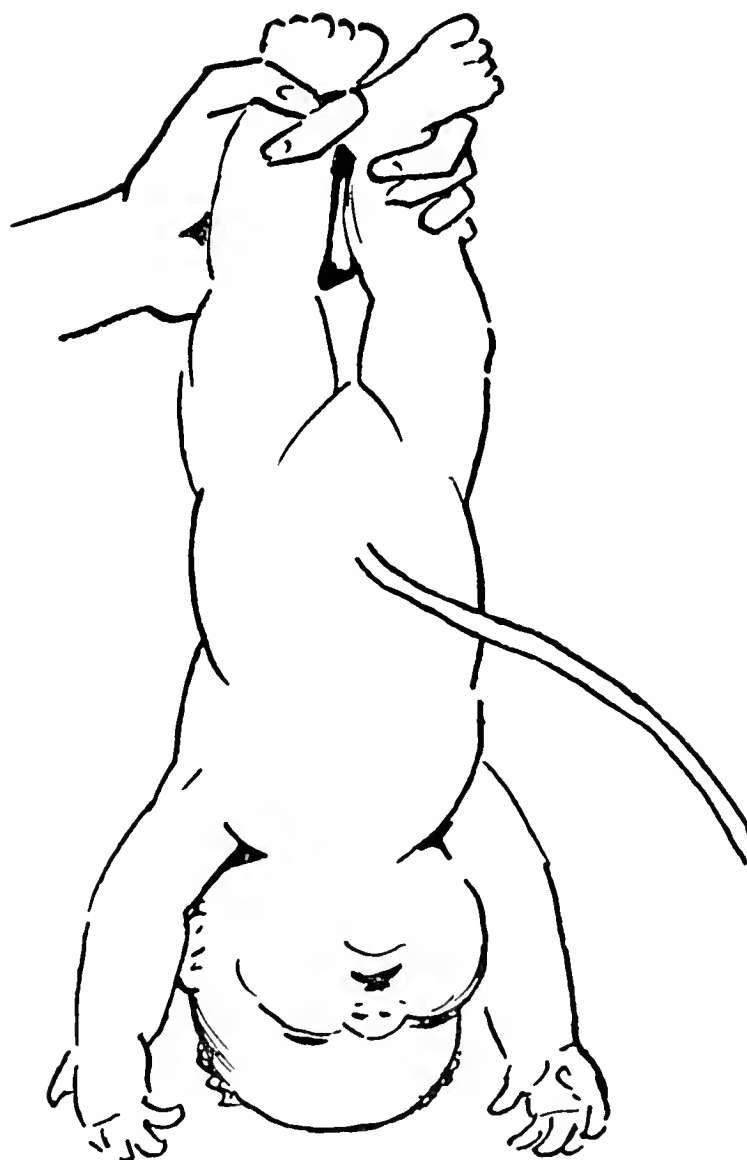

Fig. 54.—HOLDING UP BABY BY HIS HEELS.

**“Catching” the baby.**—Do not hurry. Speak calmly and quietly and describe how you continue the support while the baby turns his head. Describe how his shoulders turn perpendicular to the bed and emphasize that you do not interfere with his movement. The midwife must not attempt to turn the baby’s head for him. After a brief rest another pain will come and the shoulders and body will be born. Emphasize again that the baby is pushed out from above and the midwife should never do any pulling but should just support and “catch” the baby as he is pushed out.

**Helping the baby to get his breath.**—Grasp the baby by the heels with the left hand, support his head with the right hand, and hold him up to drain. Avoid any pulling on the cord and hold him with his head so near the mother’s inner thigh that there is no danger of injury from falling (fig. 54).

Strip his nose as if there were mucus and wipe out his mouth with the little finger as if he had phlegm. Rub the fingers up and down his back to stimulate breathing. Explain that if he does not breathe at once, tapping gently on the buttocks or snapping your finger against the



Fig. 55.—POSITION OF BABY BEFORE CORD IS CUT.

soles of the baby's feet will usually make him cry lustily. If he does not cry within 2 or 3 minutes, if he is pale all over or a bluish-purple color, send for a doctor at once. Explain that too vigorous efforts to make the baby breathe must be avoided.

When the baby has cried well and is a good warm-pink color, lay him on the clean, dry cloth between the mother's flexed legs (fig. 55). See to it that there is no pull on the cord and explain how important this is. Wash your hands again quickly as you explain that after the baby is born there will usually be a few minutes before the pains begin again when the afterbirth is being pushed out. The mother can rest in these few minutes. The midwife can tie, cut, and dress the baby's cord while she watches the mother so that she will be sure to know as soon as the pains begin again.

**Tying, cutting, and dressing the cord.**—Explain that the baby gets about one-third of a cup more blood if we wait to tie the cord until the baby's lungs fill with air and the blood is withdrawn from the afterbirth. When the throbbing in the cord stops, this withdrawal has taken place. Explain the importance of the baby's getting that extra blood.

Using the index and third fingers feel the cord for throbbing (fig. 56).

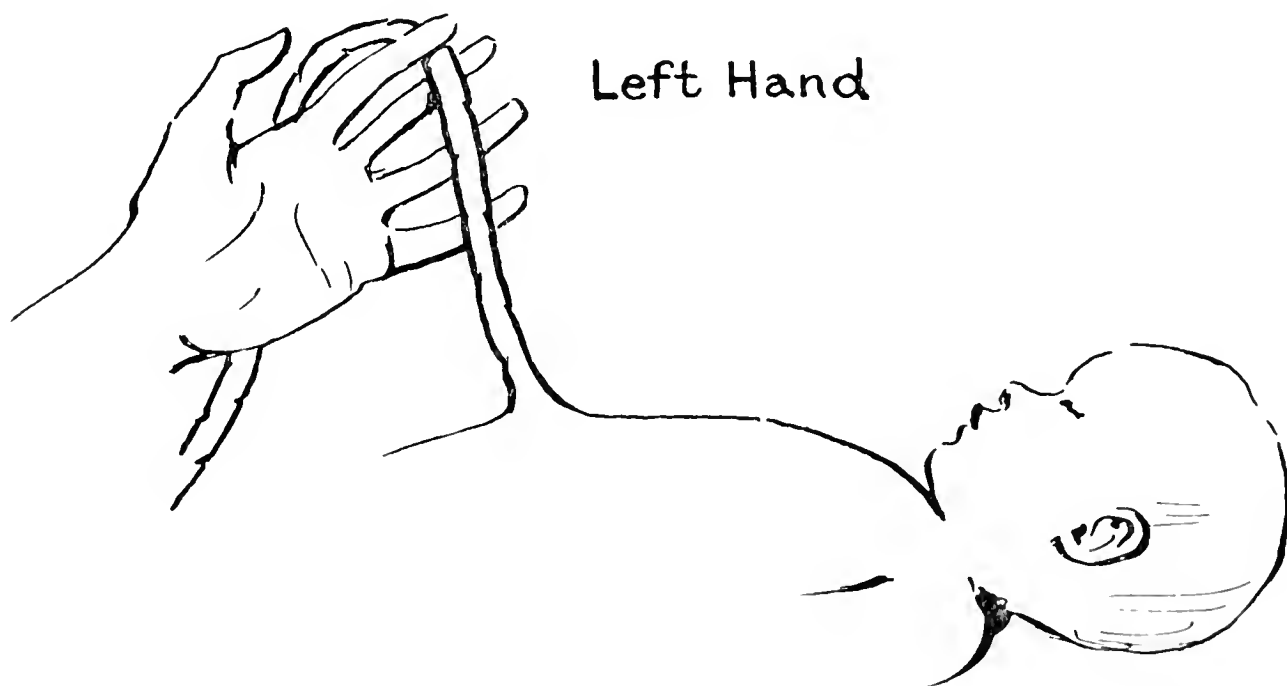

Fig. 56.—FEELING THE THROBBING CORD.

When the throbbing stops, tie, cut, and dress the cord as follows:

Make a single knot in one end of the tape (fig. 57).

Hold the knotted end in the right hand and slip the other end under the baby's cord (fig. 58).

In making the first loop, place the knotted end of the tape, which is still in the right hand, *in front of* and over the other end of the tape, transferring the knotted end to the left hand as you pull it down through the loop (fig. 59, two views).

Draw the loop to within 1 inch of the point where the cord joins the baby's skin at the navel. Draw the loop close to the cord at this point (fig. 60).

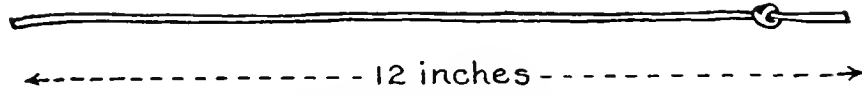

Fig. 57.—TAPE WITH KNOT AT ONE END.

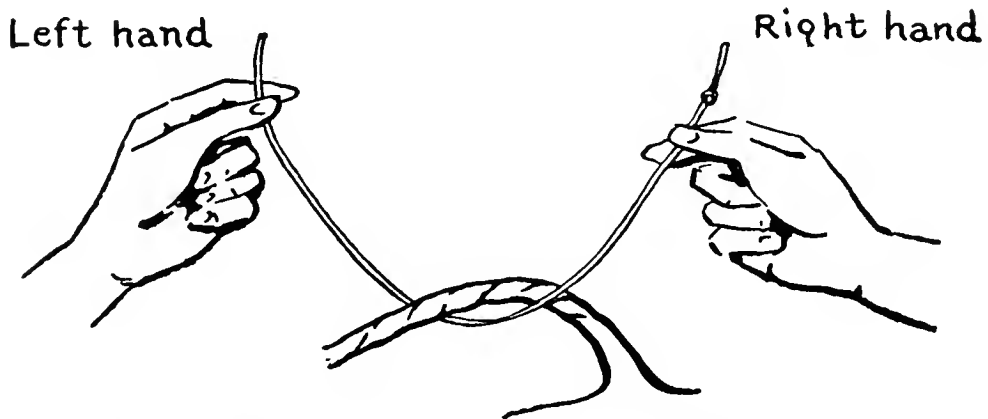

Fig. 58.—TYING FIRST LOOP OF SQUARE KNOT. STEP 1.

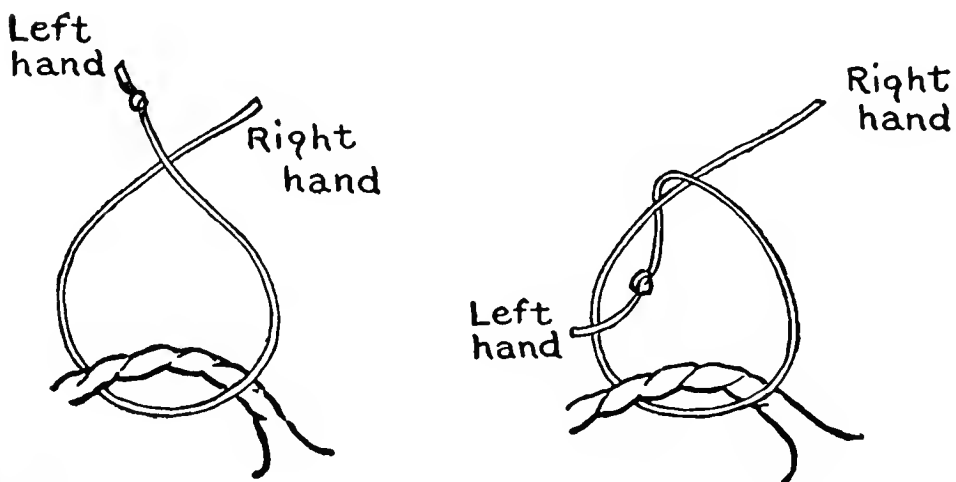

Fig. 59.—TYING FIRST LOOP OF SQUARE KNOT. STEP 2, TWO VIEWS.

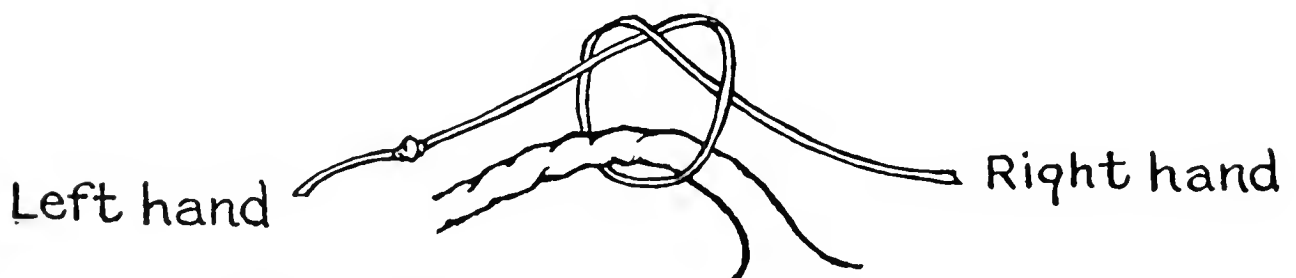

Fig. 60.—TYING FIRST LOOP OF SQUARE KNOT. STEP 3.



Place the hands under the tapes (fig. 61).

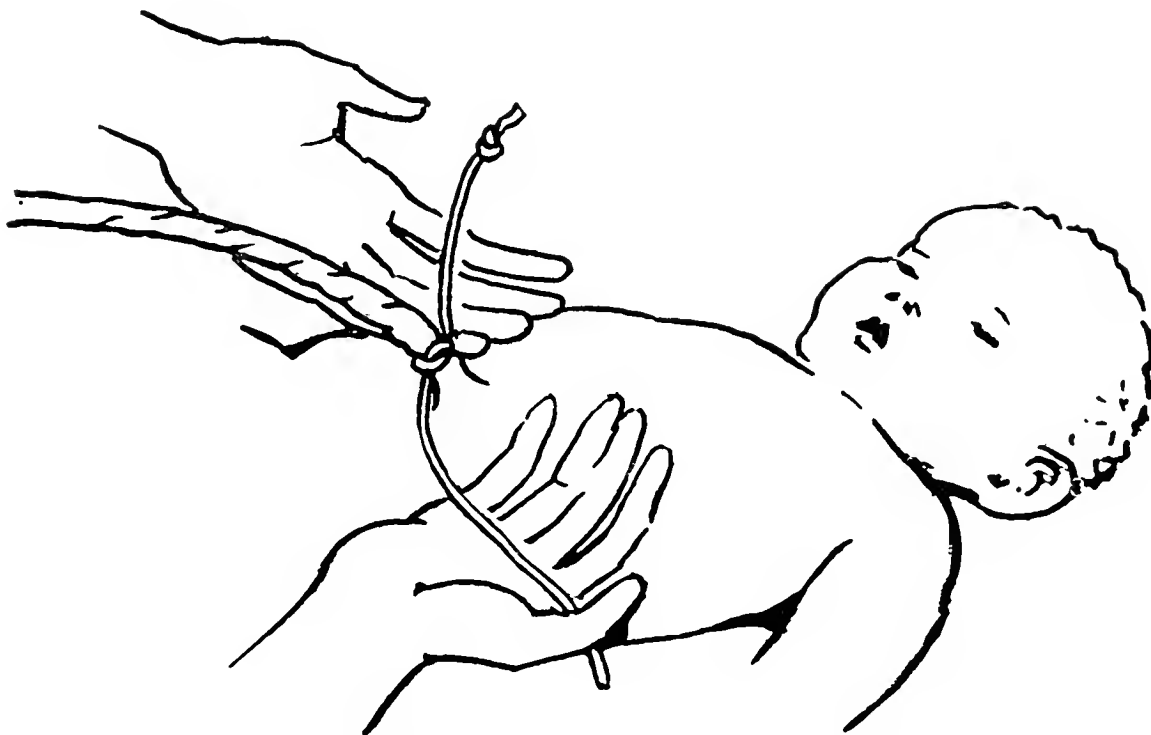

Fig. 61.—TYING FIRST LOOP OF SQUARE KNOT. STEP 4.

Pinch the tape against the index fingers with the thumb (fig. 62).

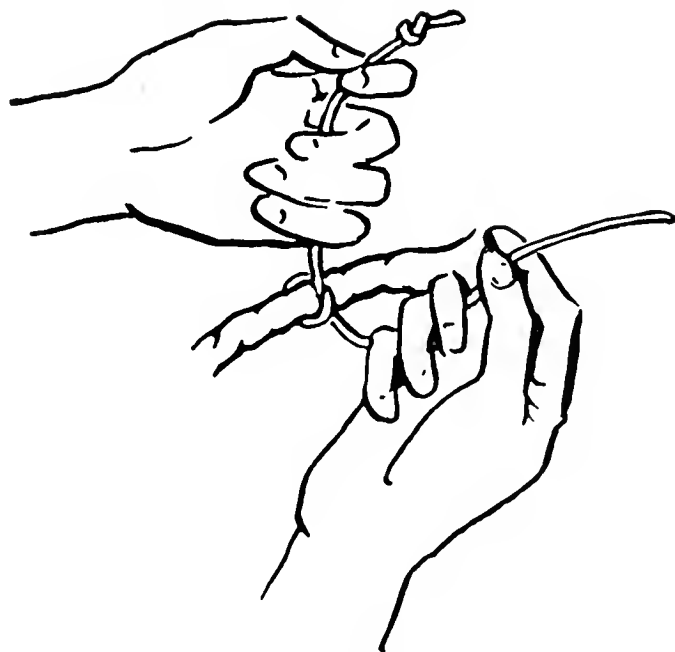

Fig. 62.—TYING FIRST LOOP OF SQUARE KNOT. STEP 5.

Roll the fists together, pulling the cord tape evenly by forcing the little fingers farther and farther apart.

Do not lift up as you do this. Avoid any pulling on the cord because of possible injury to the baby. A firm, steady pull on the tapes will tie the first loop securely and will not cut through the cord (fig. 63).

In making the second loop, place the knotted end of the tape, now in your left hand, *in front of* and over the other end of the tape, transferring

the knotted end to the right hand as you pull it down through the loop (fig. 64, two views).

Draw this loop close against the first loop (fig. 65). Slip the hands under the tapes (as was shown in figs. 61 and 62).

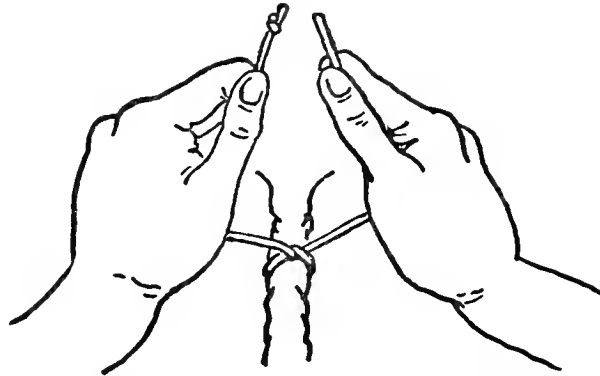

Fig. 63.—TYING FIRST LOOP OF SQUARE KNOT. STEP 6.

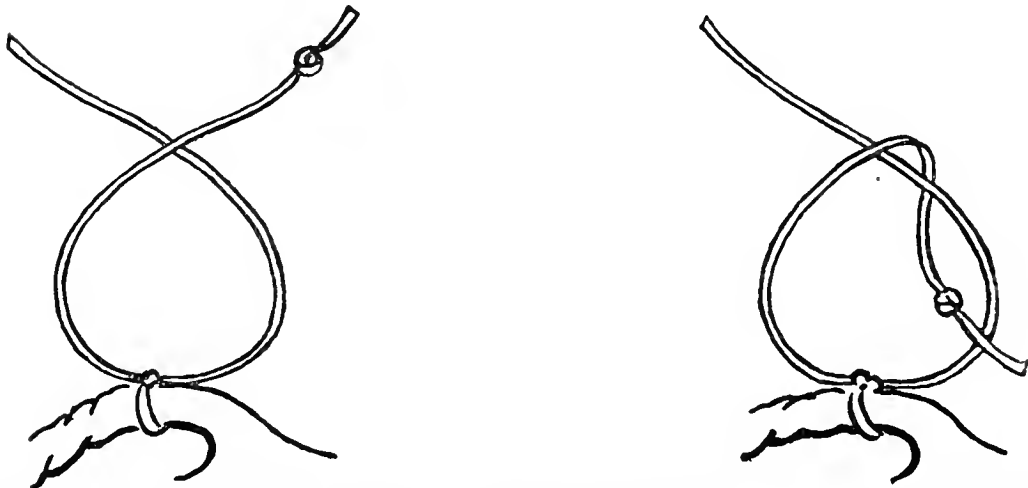

Fig. 64.—TYING SECOND LOOP OF SQUARE KNOT. STEP 1, TWO VIEWS.

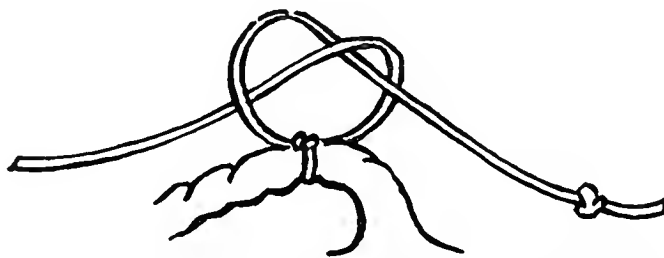

Fig. 65.—TYING SECOND LOOP OF SQUARE KNOT. STEP 2.

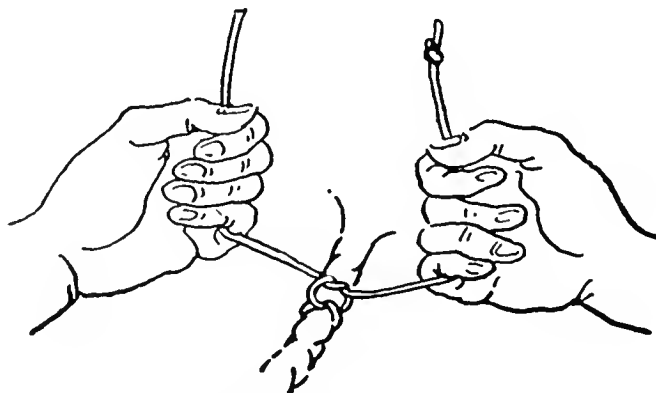

Fig. 66.—TYING SECOND LOOP OF SQUARE KNOT. STEP 3.

Pinch the tape against the index fingers with the thumbs (fig. 66).

Roll the fists together, giving a steady, strong pull, which will be felt most on the outside of the little fingers as they are forced apart.

Put a second tie on the cord about 1 inch from the first one—that is, about 2 inches from the baby's skin—repeating each procedure as described for putting on the first tie (fig. 67).

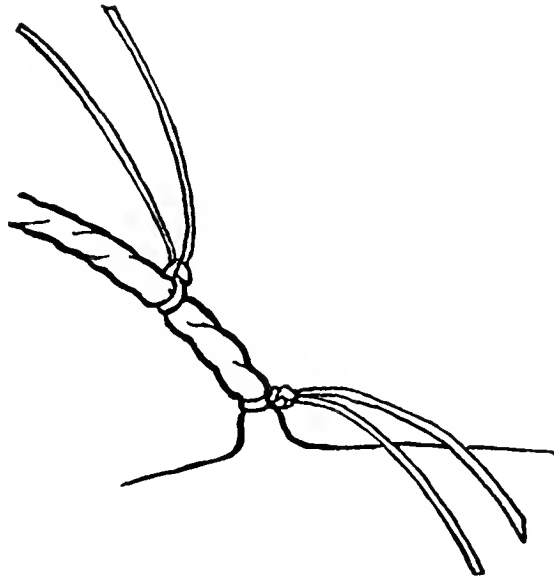

Fig. 67.—TWO CORD TIES IN PLACE.

The tie nearer to the mother serves to avoid soiling the bed with blood from the afterbirth, and in case of a twin pregnancy it may prevent bleeding of the unborn twin. The tie nearer to the baby keeps him from losing blood through the cord. It is very important that **the cord ties should be so tight that they cannot slip**. Many babies have bled to death because the cord tie slipped.

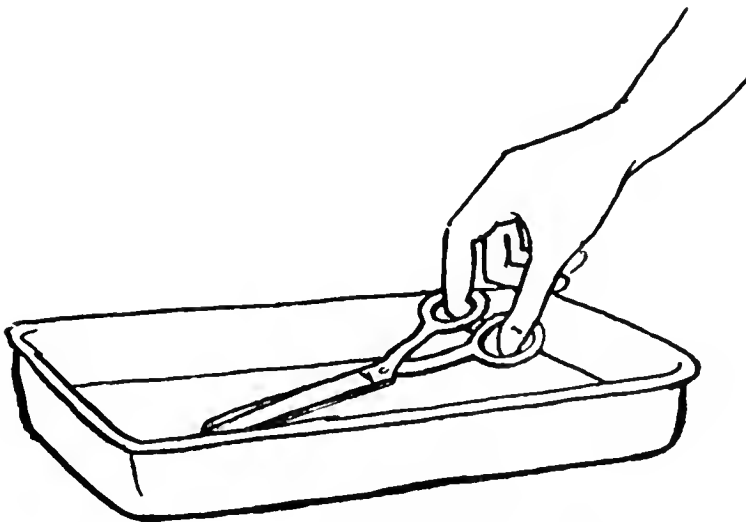

Fig. 68.—PICKING UP SCISSORS TO CUT CORD.

Remove the lid from the sterilizing basin containing the cord scissors and with the right hand pick up the scissors by the handles. Do not allow the blades of the scissors to touch anything (fig. 68).

Pick up the strings of the second cord tie in the left hand and cut the cord between the ties about half an inch from the tie nearer to the baby (fig. 69). Replace the scissors in the sterilizing basin.

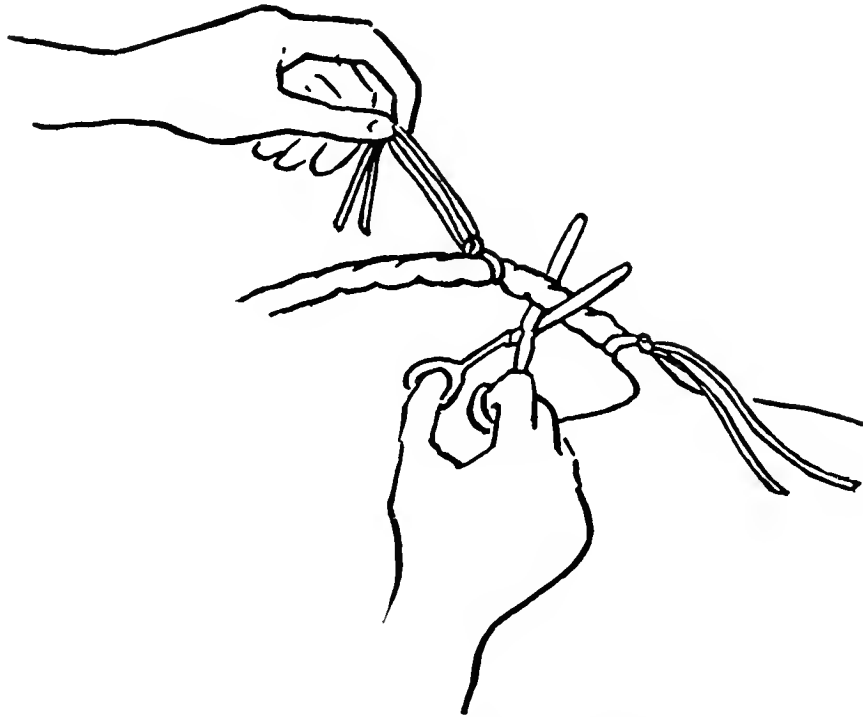

Fig. 69.—CUTTING CORD BETWEEN TIES.

Emphasize how the baby can be infected through the cord and get lockjaw or blood poison if the hands, cord ties, scissors, and cord dressing are not perfectly clean.

Pick up the ends of the tie on the baby's cord stump, one in either hand, and look carefully to see if there is any blood oozing from the end of the stump (fig. 70).

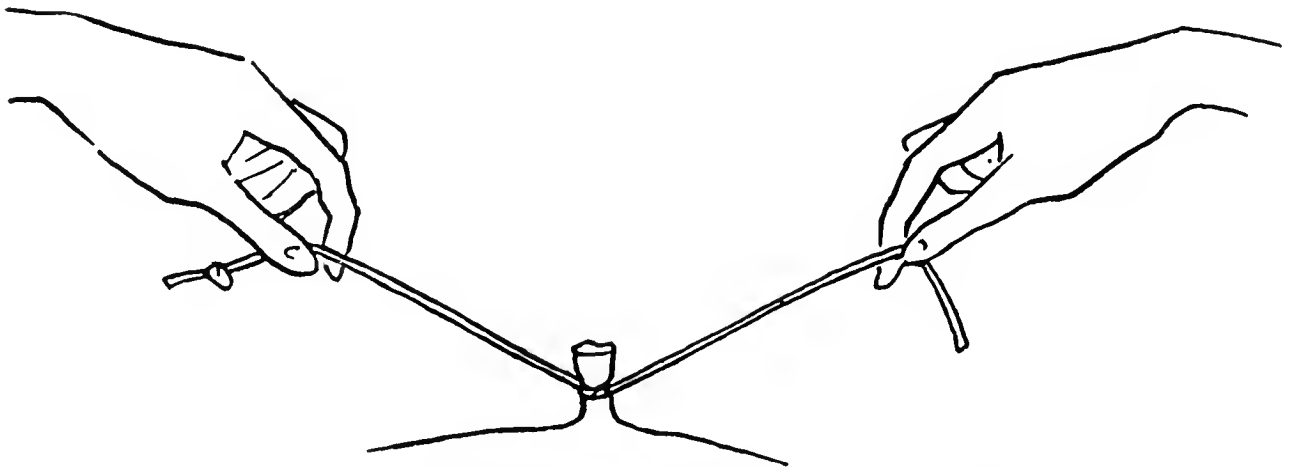

Fig. 70.—LOOKING FOR BLEEDING FROM STUMP.

Show how if there is any oozing of blood the midwife should tie another square knot on the opposite side of the cord from the first one and watch the stump to make sure the oozing has been stopped (fig. 71).

Show how when there is no oozing of blood you would pick up the upper gauze dressing in your left hand and with your right hand holding up

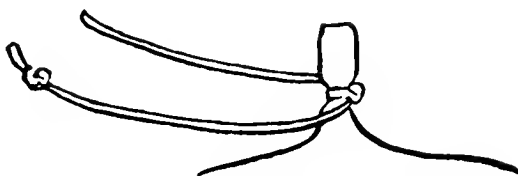

Fig. 71.—RETYING CORD.

the stump by the tape ties, place the gauze about the stump. See to it that the side of the gauze untouched by the hand is next to the cut stump (fig. 72).

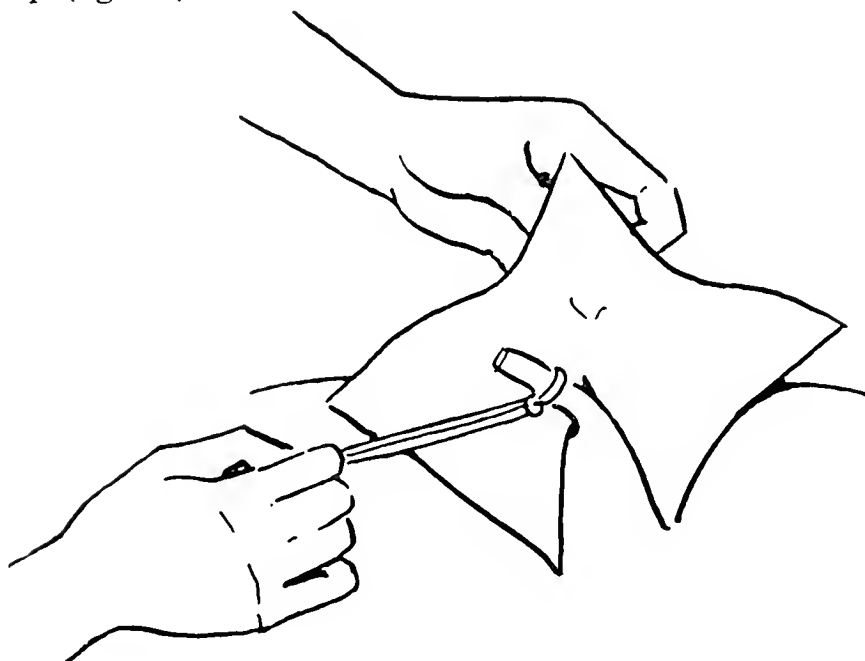

Fig. 72.—PUTTING ON CORD DRESSING.

Pick up the scissors again and cut the cord ties about 2 inches from the knot (fig. 73).

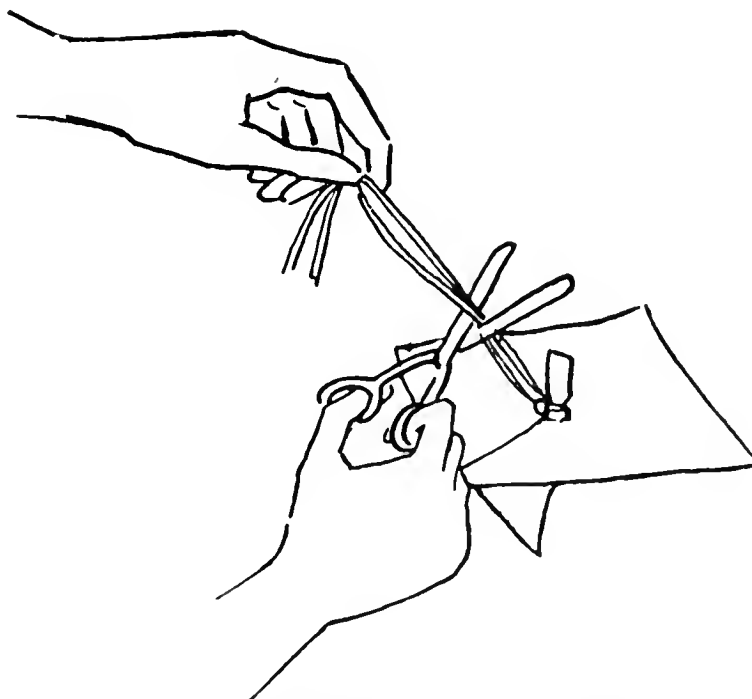

Fig. 73.—CUTTING ENDS OF TAPE.

Pick up the second gauze dressing, taking care not to carry cotton balls as well. Place it on top of the cord stump with the untouched surface down on the cut stump (fig. 74).

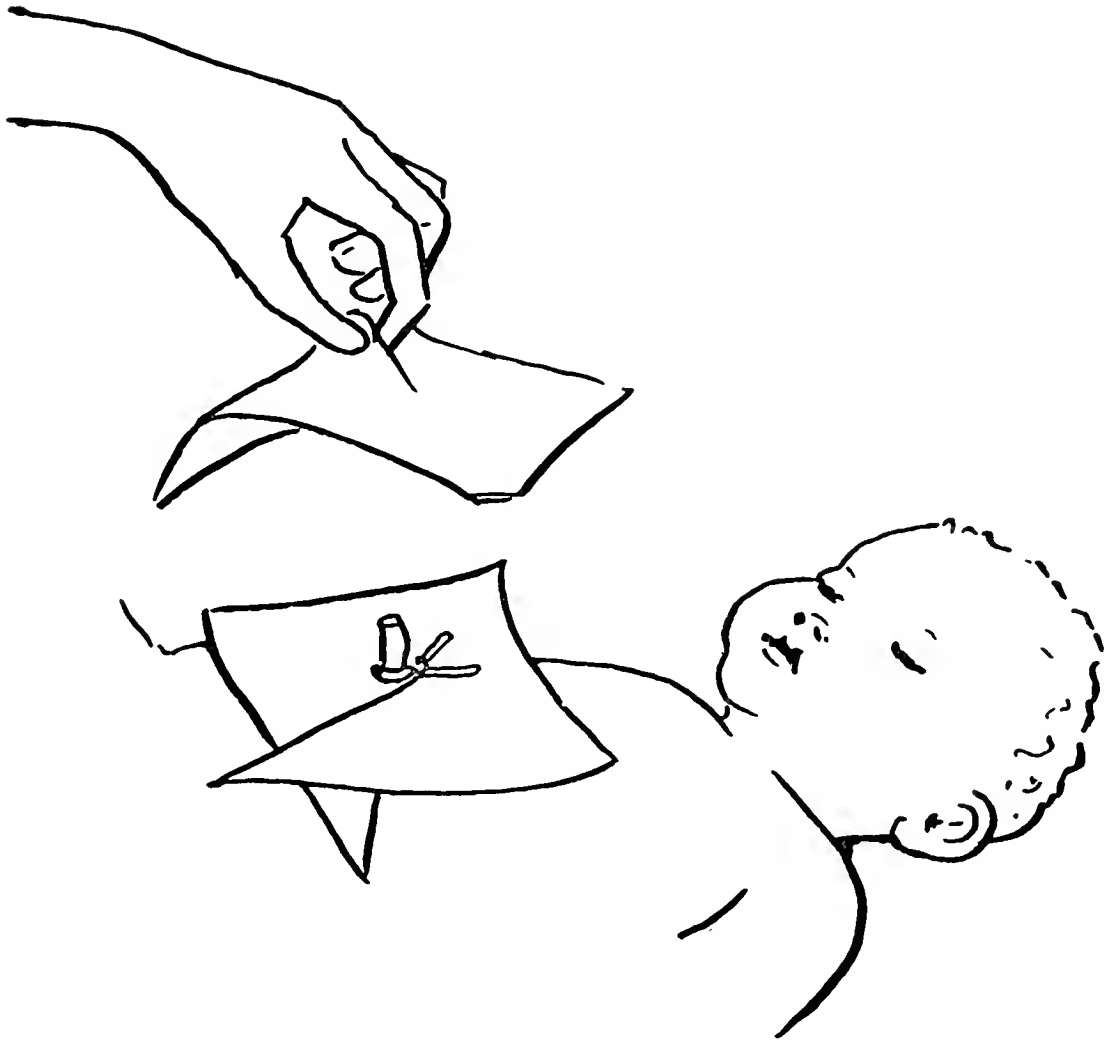

Fig. 74.—APPLYING SECOND SPONGE.

Quickly apply the baby binder so that it is snug, smooth, and not too tight, to keep the dressing in place (fig. 75). Pin it carefully.

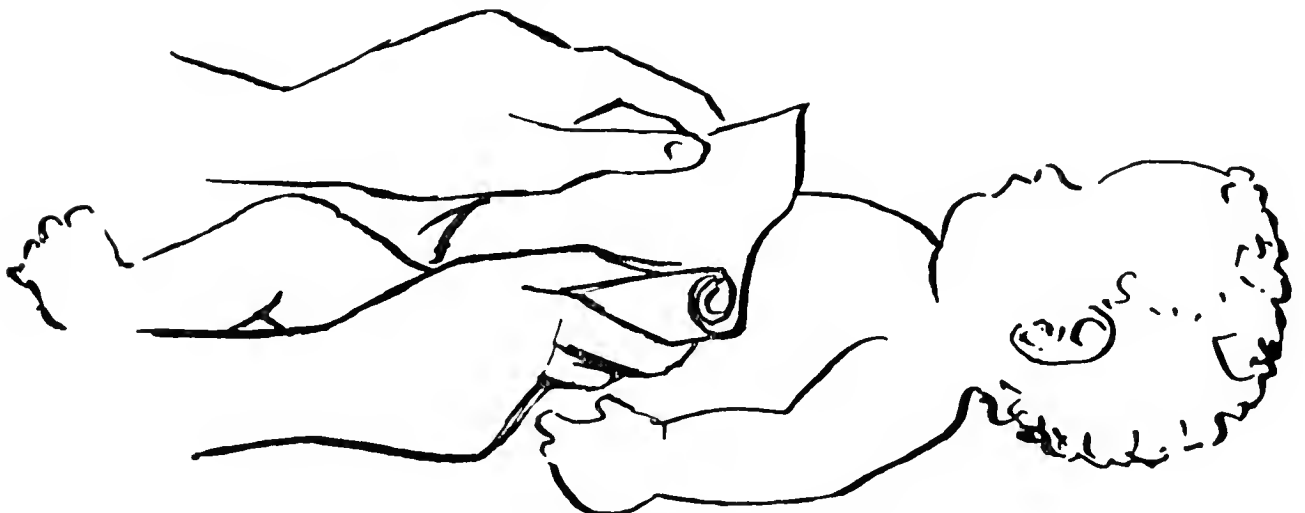

Fig. 75.—APPLYING BINDER.

Emphasize again that the baby's cord must be tied, cut, and dressed so that it cannot bleed, will be protected from infection, and will be kept clean until it drops off when the navel is healed. Every detail is very important and the midwife is responsible for doing it exactly right.

**Putting the baby in his bed.**—Now reach for the receiving blanket. Take the warm iron from the blanket and wrap the baby securely in the warm blanket, making sure that the arms and hands are well covered (fig. 76).

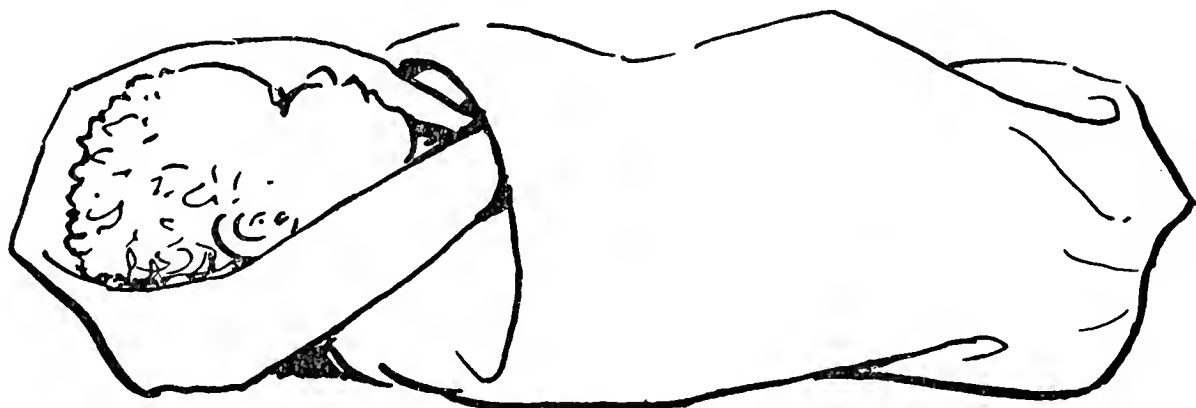

Fig. 76.—BABY IN RECEIVING BLANKET.

Ask the family to remove the iron from the baby's bed. Place the baby in his bed with the feet slightly higher than the head (fig. 77). Have the family cover him snugly with the warmed blankets. The bed must be where the midwife can take a quick look at the baby's binder and watch his face constantly while she stays with the mother. He might choke with mucus and suffocate if not watched so that the mucus could be drained if it should collect in his throat. Describe the sound of a mucus rattle and of a moaning breath when there is mucus in a baby's throat and show how to pick him up again so that the mucus can drain out. If the condition does not clear up quickly, or if his color is not a warm pink, or if the cord stump bleeds after the midwife has tied it securely, the midwife should send for a doctor at once.

**When there is not time to complete the cord dressing.**—Watch the mother constantly while you are working with the baby. Explain that the afterbirth may separate at any moment and the mother need the midwife's attention. After the first cord tie is tied the rest of the baby's care could wait if the mother should need the midwife. Show how the midwife can cover the baby's body (not his head) with his blanket without stopping to cut the cord and put on the dressing, and can keep him between his mother's legs, where he cannot fall and where there will be no pull on the cord, until the midwife can, with safety to the mother, finish his care.

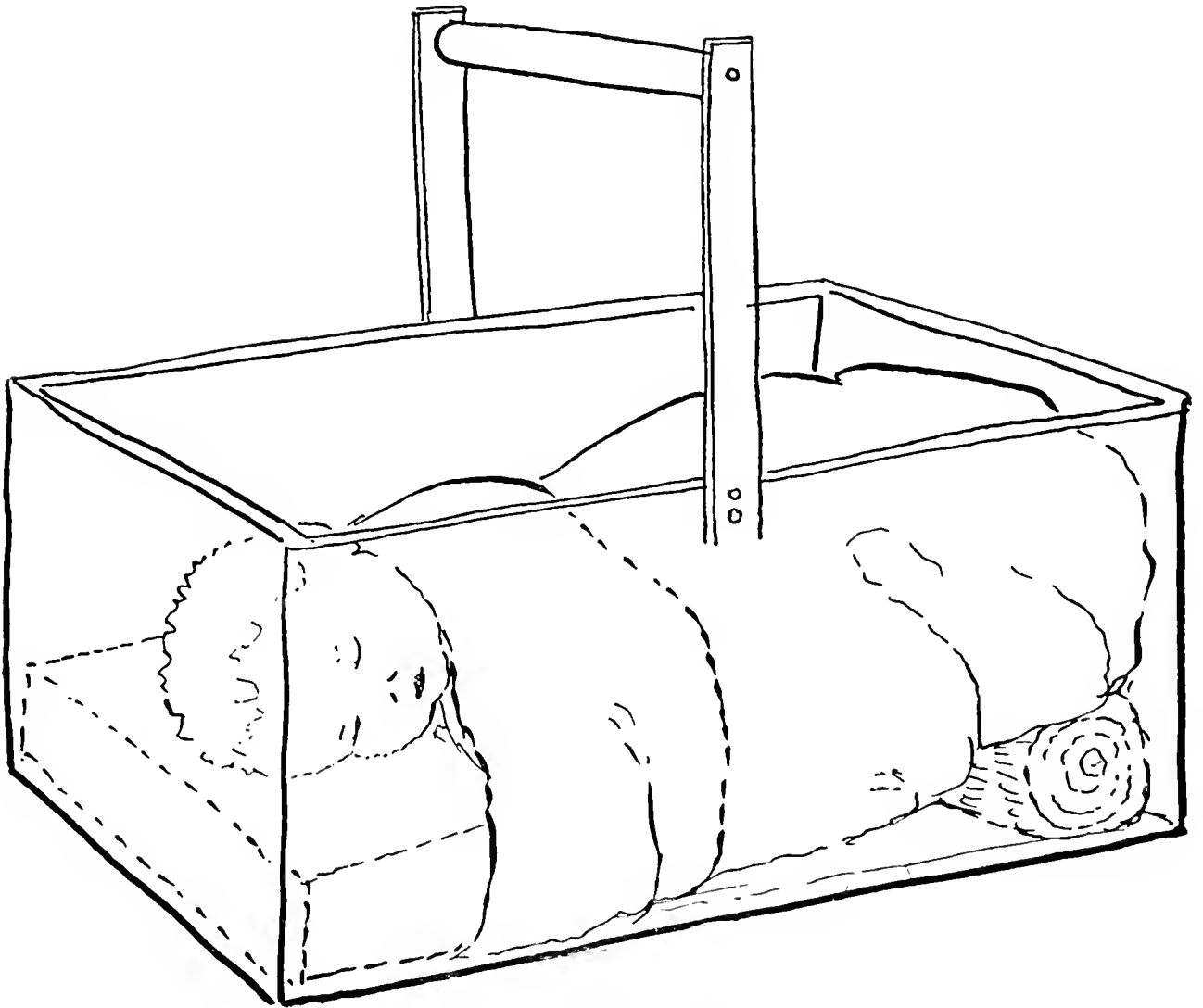

Fig. 77.—BABY IN BED.

### SUMMARY

The management of the second stage of labor means:

- A.* Showing the mother how to use and not waste her power—the contractions of the muscles of the uterus and abdomen.
- B.* Watching her every moment to make sure that a doctor will be sent for in time if the labor does not progress normally.
- C.* Protecting the passage from infection or injury.
- D.* Cherishing the passenger by receiving him gently and safeguarding him from falling, suffocating, hemorrhaging, being infected, or being chilled.
- E.* Watching the mother for third-stage pains.



## **Lesson XIV.**

# **Some Midwife Procedures During the Second Stage of Labor**

## **A PRACTICE PERIOD**

### **Purpose**

To give the midwife an opportunity to practice some of the procedures of lesson XIII.

### **Equipment**

The same as for lesson XIII and, in addition, 15 "demonstration" packages of cord ties and dressing, and enough strong, thick string for each midwife to practice tying square knots and for each midwife to have a fresh piece to attach to the baby doll so that she may practice tying the cord.

### **Procedure**

Explain that each midwife will have a chance to practice doing some of the things that you did at the last lesson. Have each midwife, in wash dress, cap, and mask, in turn take her position at the mother's bed. Begin by seeing that the table of supplies is in order and that she can reach everything before she breaks the seal of the sterile package and opens it half way and opens the package containing the midwife apron without touching the apron.

Ask her to tell you how she would scrub her hands. Then have her put on the apron, using the one from her bag so that it will fit her. Then she should drape the mother and wash the mother's vulva with the sterilized wipes.

Telling her that the baby's hair is now in sight, have her open up wide the sterile package and wash her hands. Show her how she would help the mother to stretch and relax between pains and to "pant" when the head is about to be delivered. Have her support the head with one hand and wipe the mucus from the baby's eyes with the cotton ball, feel for the cord around the baby's neck and release it if necessary, but avoid interfering with the turning of the baby's head.

Then tell her the baby is just born and ask her to show you how she would pick him up by his feet to let the mucus drain and how she would wipe his nose and mouth and make him breathe well. Have her soap

her hands and rinse them well. Then have her tie the cord, following each step as shown in the drawings. She should look at the pictures in her copy of the manual so that she can practice between classes. If she makes a mistake, be sure to tell her at once and have her do over again and do correctly anything she first did incorrectly.

Have her put on the cord dressing and binder and wrap the baby securely in his blanket, then put him into his bed with his head slightly lower than his feet. Have each midwife go through all the procedures if possible and arrange for her to practice if she has trouble learning to do correctly any part of any procedure.

## The Midwife's Management During the Third Stage of Labor

### A DEMONSTRATION

### TEN-MINUTE REVIEW

What happens during the second stage of labor?

What are the dangers to the baby?

What are the dangers to the mother?

Why is it important to warm the baby's bed and blankets before he is born?

Why should the midwife wait until the cord stops throbbing before she ties it?

Why should the midwife tie the mother's end of the cord?

What would you do if you dropped the scissors on the floor just as you were about to cut the cord?

### Purpose

To show the midwife how to manage during the third stage of labor so that she can—

- A. Receive the placenta.
- B. Watch the mother while she cares for the baby.
- C. Watch the baby while she cares for the mother.
- D. Leave the mother and the baby clean and comfortable.
- E. Show the family what to do until she comes again.

### Equipment

Same as at the close of lesson XIII.

### Procedure

The supervisor who is demonstrating should have on a gown, cap, and mask when she explains that this lesson continues with the care of the mother and baby until they can be left clean and comfortable in their clean dry beds.

At the close of the last lesson the mother was in bed draped and covered to prevent chilling while she rested and waited for the afterbirth. The midwife had just put the baby, securely wrapped in a receiving blan-

ket, in his bed, where she could watch his color, listen to his breathing, and look at the binder every few minutes.

**Waiting for the afterbirth.**—While waiting with the mother for the pains to come again look at the baby every few minutes. Place the left hand, palm down, on the mother's abdomen just below the navel so that you can feel the womb and explain that the midwife should keep her hand quietly in this same position as long as the mother's uterus stays firm and does not grow larger. She should not rub or knead the mother's abdomen. Using the right hand, wipe off the secretion from about the vulva with well-wrung boiled wipes, one stroke down with each wipe. Get the empty basin that you used as a cover for the boiled wipes from the foot of the bed where you put it (lesson XIII, p. 101) and place it against the buttocks so that you can drop the end of the cord into it.

**If the mother bleeds.**—Explain that sometimes the uterus does not contract as it should after the baby is born and the mother may bleed either before or after the afterbirth is expelled. A glance at the vulva every minute or two will show the midwife if there is any bleeding on the outside. But sometimes mothers bleed on the inside without much blood coming to the vulva. A pale face, sweating, cold hands and feet, excitement, exhaustion, a great thirst, a soft, doughy womb are the signs of internal bleeding. If any of these signs of internal bleeding or any external bleeding of more than one cup appears either before or after the afterbirth comes, the midwife should send for a doctor at once, telling him the trouble so that he will come without delay.

While waiting for the doctor, the midwife can gently rub the mother's abdomen around the navel until she feels the uterus hardening under her hand, or if she does not feel it in a few seconds, she can have someone help her raise the foot of the bed and rest it on the seats of two strong chairs, one under each corner. Show her how to do it. Emphasize the importance of keeping the mother quiet and warm by using hot drinks, warm blankets, a warm flatiron at her feet. Show her how to put the baby to the breast because suckling may help to stimulate the uterus to contract as it should.

Be sure the midwife understands that it is quick work without excitement that is needed if the mother bleeds too much. Watching the mother constantly and knowing what to do while waiting for the doctor are the best ways for the midwife to help in case of bleeding.

**The pains begin again.**—Explain that usually there is a brief resting period after the baby is born. Then the uterus will begin to contract with pains to push out the afterbirth. The signs to watch for are—

- A. The pains the mother will feel and the contractions the midwife can feel with her left hand.
- B. A little gush of blood at the vulva. The blood was expelled from the uterus when the afterbirth was being pushed out.
- C. The cord slips down and slides farther out of the birth canal as soon as the afterbirth is pushed from the uterus into the birth canal.
- D. The uterus feels rounder, smaller, and harder and rises up above the navel as soon as it has expelled the afterbirth.

**“Catching” the afterbirth.**—Explain that the contractions which caused the pains will usually expel the afterbirth from the uterus, but the mother must bear down strongly at the time that she has the pain to push the afterbirth out of the birth canal into the basin. Explain why the midwife should notice whether the membranes seem to tear as the afterbirth slides out of the birth canal into the basin. The midwife must not attempt to hurry the delivery of the afterbirth. She should **never** pull on the cord and **never** put her hand or finger inside the birth canal to get it away. Make it clear that the midwife should call a doctor if the afterbirth does not come away in an hour. When the afterbirth is in the basin she can put it out of the way, but she must look it over carefully later and observe the points referred to on page 120.

**Making the mother comfortable.**—Show how to wipe away all the blood from the vulva, using one of the boiled wipes for each downward stroke while you look to see if the parts are torn. A tear will look like a lip with a fresh cut in it. Explain that if the midwife finds a tear she should send for a doctor to repair it. It is a simple thing to do at the time, but not doing it then means trouble for the mother and an operation later.

Turn the mother on her side. Wash and dry her back. Put on a clean sanitary pad without touching the part that goes next to the mother. Explain that the old-fashioned T-binder is no longer advised when the mother is in bed because it is so quickly soiled and because it holds the sanitary pad too close to the vulva. Take out the soiled under bedding and remove the stockings. Straighten the bed, cover the mother, and tuck the covers in at the foot and sides, making the mother cozy and warm. Explain that the mother should lie on her back with her knees together for the first few hours.

Ask someone in the family to prepare hot coffee, cocoa, tea, or soup and some toast for the mother. Explain why she needs nourishment.

Explain why the midwife should lay her hand gently on the mother’s abdomen to feel the uterus and should look at the sanitary pad every few minutes to see how much the mother is bleeding. Except for this nothing

needs to be done for the mother while the baby is cared for and the place made tidy, and she should be allowed to rest.

**The afterbirth.**—Show how you would look carefully at the afterbirth (fig. 78, two views). Perhaps you can get one for the demonstration. Hold the placenta up by the cord (baby side out). Note the size, where the cord is attached, any big blood vessels that lead to the edge and appear

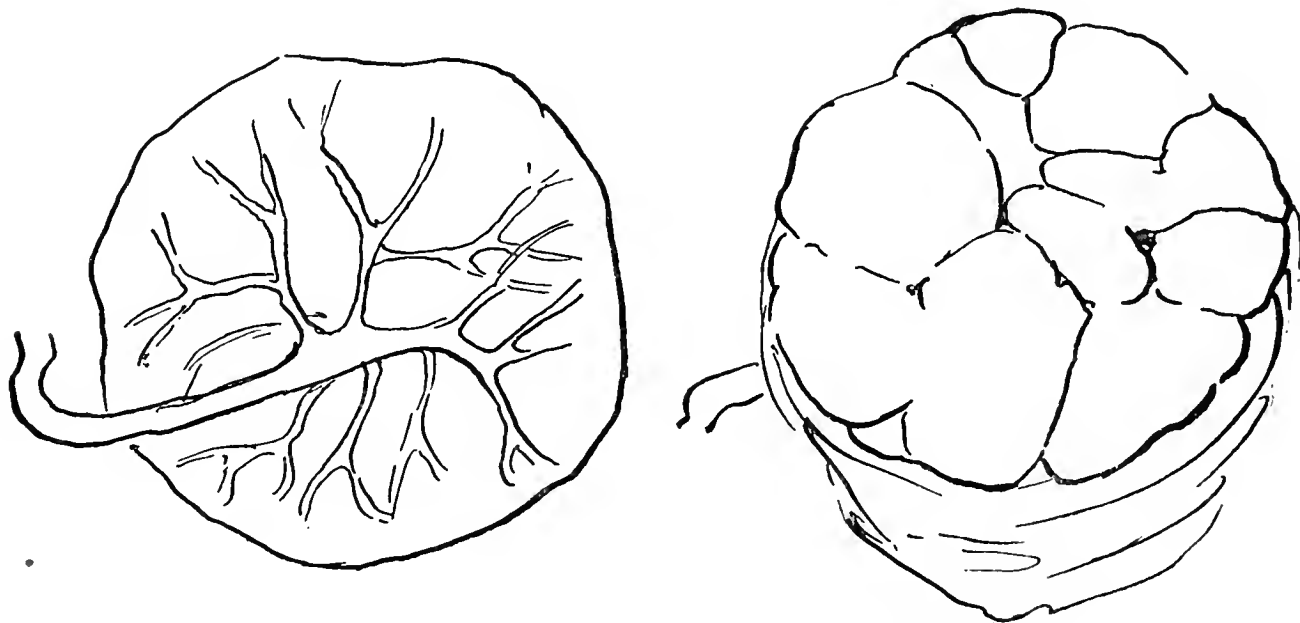

Fig. 78.—THE AFTERBIRTH. TWO VIEWS.

to be broken off, or any apparently missing part of the sac, especially near the slit that the baby comes through. Note the color. Does it look like fresh meat or does it look dark and old or slightly decayed? Note the odor. Has it a fresh-meat odor or has it a spoiled offensive smell? Turn the afterbirth so that the fleshy side can be seen. Hold it in your cupped hands. Is the surface smooth, like biscuits baked close together in a pan, or is it rough—as if the top of the biscuit had been removed? Do the biscuits fit together when the hands are cupped or do some of the biscuits appear to be missing? Do the biscuits look soft and smooth or are some of them rough and lumpy? Explain why, if any part of the membranes or afterbirth is missing or if the afterbirth is unusual, the midwife should save it and call a doctor. She should not attempt to find or remove any missing part herself.

If the afterbirth is complete, the midwife can wrap it in the soiled papers and have the family burn it at once.

**Tidying up.**—With the family's help arrange the delivery room so it will be easy to care for the mother. Take the package with the two sterile cotton balls to the kitchen and put it beside the baby tray. The midwife should see that all the soiled bed linen, towels, and so forth are put to soak so that they can be washed, boiled, and dried in the sun as

soon as possible. She should arrange to have the soiled papers and useless rags burned and the usable ones put to soak. She can have some one scrub, rinse, and dry the basins while she gets ready to care for the baby. See that the light is not shining in the mother's face. See that she has drinking water where she can reach it and explain why she needs to drink plenty of water. Then carry the baby in his bed out to the kitchen.

**Caring for the baby.**—First wash your hands, then see that everything is ready in the kitchen as you left it in lesson XI (p. 84). Explain that if the labor were short and the time for preparation limited, the midwife might have to prepare the baby's tray and supplies at this time. See that the room is warm and the oil the right temperature to use. Half fill the nursing bottle with boiled water from the pint bottle, put on a nipple, and set it in a saucepan of warm water on the back of the stove to warm.

Then move the table where the light is right so that you can put the drops in the baby's eyes just as you did in lesson XI (p. 85), explaining the reason for each move as you work.

Then, when you have checked the mother's condition and washed your hands, move the table back close to the stove and take the covers off the jars. When everything is ready open up the blanket. Do not disturb the binder or cord dressing.

Using cotton balls, put the warm clean oil on the baby's head, neck, arms, chest, back, buttocks, and legs. This warm oil will dissolve the white cheesy material on the baby's body and keep his skin in good condition. Gently remove the oil with a soft old towel. Apply more oil in the skin creases and on the genitals. Explain that if this cheesy material sticks fast to the baby's skin, the midwife must be careful not to rub too hard or the skin will get red. Wipe very lightly and apply more oil, allowing it to soften until the next day, when it can be removed easily. Avoid chilling the baby. Remind the midwife that she can help to prevent infant deaths by keeping the new baby warm. If scales are available, weigh the baby with the band on. The midwife can lift the mattress and baby out on the table or can hold him on her lap to oil and dress him.

While you are oiling the baby, notice the condition of the baby's skin, which should be pink and smooth. If it is rough, dry, and scaling, with a rash, moist blobs or pustules, it is not normal and the doctor should be called. Show how you would inspect the baby carefully back and front to discover anything that is not normal. When the baby cries look into his mouth for cleft palate or tongue-tie. Look to see that the

anus is open. Count the fingers and toes. Explain that clubfeet and other deformities or abnormalities should be reported to a doctor within a few hours because the corrective treatment is usually more successful when it is started soon after birth.

Slip out the receiving blanket and dress the baby quickly, handling him as little as possible. He needs only a shirt, diaper, and dress. Then wrap him in the flannelette square so that he looks his best and show him to his mother. Give him a drink. Explain that if it is warm enough and the mother is not too weary you would carry the baby and his bottle into the mother's room so that you could sit by her bed and she could watch you give the baby his first drink of water. Be sure the midwife knows how to hold the baby and the bottle. Explain that if possible the midwife should have someone in the family watch her do everything she does for the baby and should show some grown person how to prepare the bottle of boiled water and how to hold the baby.

Then put the baby securely wrapped in his blankets in his warm bed with his head slightly lower than his heels so that the mucus can drain from his nose and throat.

Feel to see if the mother's uterus is still well contracted and look to see if there is any bleeding. Then help to straighten the kitchen and get everything back in its place. Make out the birth certificate. Explain that the midwife should always do this before she leaves the house so that she can take or send it to the local registrar without delay.

**Caring for the vulva.**—Describe an adult member of the family as if she were at your side and then explain to her how important it is to keep the mother clean and dry at all times and show her how to change the pads and keep the vulva clean.

Explain that proper care of the vulva will help to prevent childbed fever, to promote healing, to keep the mother clean and comfortable, and to prevent offensive odors. Explain that it is so important to guard the birth canal from germs that the person who cares for the mother's vulva should wear a mask and no one who has a cold should care for the mother if anyone else can be found to do it. Three or four thicknesses of clean muslin or close-woven gauze tied over the mouth and nose will make a satisfactory mask. A clean one should be used each time.

Then collect from the mother's supplies the things you will use:

- A. Two basins of the same size.
- B. Newspaper bag.
- C. In a folded newspaper, a bedpan or a tin baking pan with a smooth board covered with newspaper and placed across one end of the pan.
- D. A blanket.



- E.* A clean folded newspaper pad.
- F.* An unopened, sterilized sanitary pad.
- G.* The mother's soap dish and soap.
- H.* Twelve wipes—4-inch squares of clean rags or large swabs of grade-B absorbent cotton.
- I.* Several newspapers.
- J.* A mask. (Use the improvised one made from clean muslin to show how it works.)

Put the wipes to boil in the basins. (See lesson XII, p. 90.) After the water bubbles, let them boil for 10 minutes. Then set them off the stove to cool with the cover still on. While they are cooling carry all the other things to the bedside and arrange them conveniently on a newspaper-covered bedside table or chair. Remember to talk to the doll as if it were the mother, telling her what you are going to do and asking her how she feels.

With the mother lying on her back turn up the nightgown to the waistline. Turn down the top bedcovers to her waistline and place the small blanket across her chest. Put the newspaper bag on the foot of the bed. Ask the mother to bend her knees and raise herself with her feet flat on the bed. With one hand supporting her hips slip the bedpan under her with the other hand. Remove the soiled pad and comment on the significance of the amount of discharge, the color, odor, and presence or absence of clots. Drop the soiled pad in the paper bag on the foot of the bed. Ask the mother to pass water if she can. Leave her alone for a few minutes while you bring to the bedside the covered basin of boiled wipes and wash your hands.

Take the cover off the basin of wipes and set the basin on the foot of the bed. Pick off the top wipe; wring it nearly dry. Show how you wipe off the secretion, using each wipe for one downward stroke, dropping them in the newspaper bag, and using as many as are necessary to remove all the secretion from the outside of the vulva. Emphasize why you do not separate the parts or touch the inner surface of the vulva. Then go over the vulva again, using soap on every other wipe and rinsing it off with the next one and discarding each wipe after each downward stroke. Then wash the inner surfaces of the thighs, remove the bedpan, and cover it with newspapers. Turn the mother on her side so that you can wash the buttocks and around the anus, using several wipes at once and plenty of soap and rinsing off the soap thoroughly. Wring the last wipe very dry. Put on a clean sanitary pad without touching the surface that goes next to the mother. Roll up the soiled newspaper bedpad and push it under the mother's hips. Spread a clean one next to it and

roll the mother over on the clean pad (fig. 79). Remove the soiled one, straighten the fresh one, and cover the mother. Explain that she should lie quietly with her knees together for the next few hours.

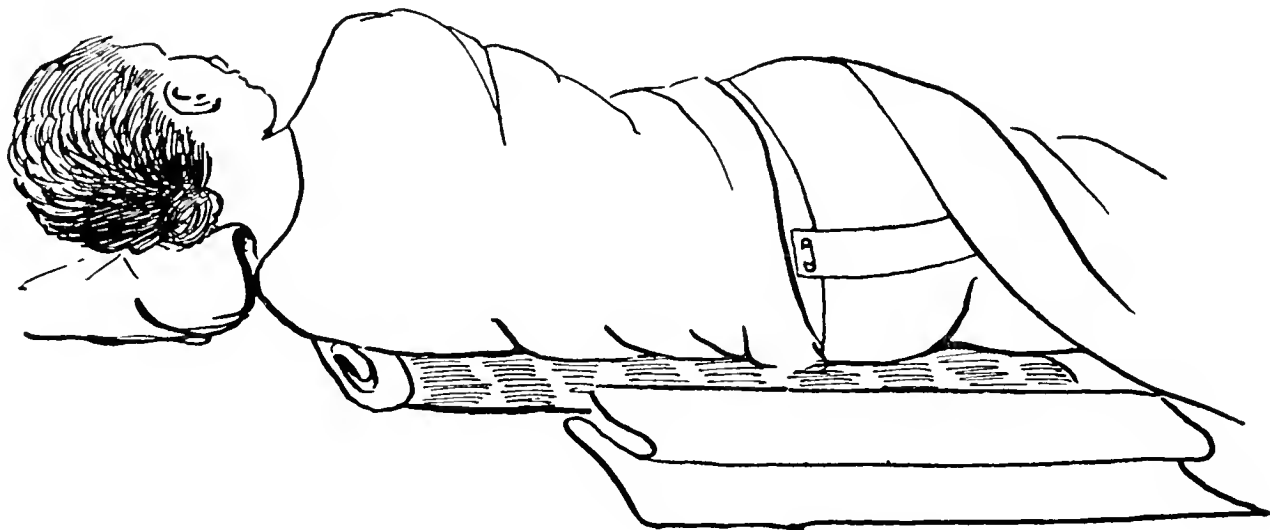

Fig. 79.—PLACING MOTHER ON CLEAN NEWSPAPER PAD.

Show how to empty the bedpan and wash it with soapsuds, scald it inside and out, and wrap it in a clean newspaper cover. Keep it in the mother's room. Explain that when a paper bedpan is used it should be burned.

Tell how if rag wipes are used and there are plenty you would burn them; if they are scarce, you would have them washed, boiled, and dried in the sun to use again. If, instead of rag wipes, swabs of absorbent cotton are used, they should be burned.

Wash your hands thoroughly and emphasize again the importance of washing the hands before and after caring for the mother's vulva, of using each wipe for one downward stroke, and of not touching the inner surface of the vulva.

Explain why it is necessary, as long as there is any discharge, to change the sanitary pad every 4 hours and oftener when it is soiled. Explain why the vulva should be washed with the boiled wipes every 4 hours and after each bowel movement as long as the mother stays in bed.

Explain that when the mother's bowels move, her buttocks should be wiped with toilet paper and the bedpan emptied and washed or, if made of paper, exchanged for a clean one.

**The first nursing.**—Explain to a responsible person that the baby should be put to the breast from 6 to 12 hours after birth and show how this is to be done, as the time for it may come before your second visit.

After washing your hands take the jar of large swabs and the jar of boiled water for washing the mother's breasts from the baby

tray to the mother's bedside. See that the mother is in a comfortable position and wash one breast with the swabs. Bring the baby in and show how to put him to that breast in a comfortable position (fig. 80). Explain that he should nurse for 5 minutes and that his throat should be watched to make sure he is swallowing and getting something as he nurses. After he finishes, the breast



Fig. 80.—THE FIRST NURSING.

should be washed again. Explain that at the next nursing he should be put to the other breast for 5 minutes and that the breasts should always be carefully washed before and after each nursing.

Explain that the nursing may help to contract the mother's womb and lessen bleeding. What the baby gets at the breast for the first 3 or 4 days is not milk but a thick yellowish fluid called colostrum. Having him nurse will stimulate the breasts to secrete milk. It will also convince the family that he can nurse and swallow. Explain that he should be brought to the mother for nursing, first at one breast, then at the other, every 4 hours—at 6 and 10 o'clock in the morning, at 2 and 6 o'clock in the afternoon, and at 10 o'clock at night. For the first 48 hours he should be nursed for only 5 minutes each time so as not to make the nipples sore.

Now put the baby back into bed, pack your bag, and leave after again inspecting the mother and explaining to a responsible person the need for continuing to observe the mother and the baby and for calling you at once if there is any change in the condition of either that is not understood. Tell the mother when to expect you, which will be between 5 and 10 hours later, depending on the hour the baby is born.

Be sure to fill out the birth certificate before leaving the house.

### SUMMARY

During the last stage of labor the midwife must remember to watch the mother and the baby. Neglect of either for even a minute might be fatal. The doctor must be called if the afterbirth does not come within an hour; if the mother loses more than a cup of blood before or after the afterbirth; if the uterus is soft and doughy; if the edges of the birth canal are torn; if the mother is cold, pale, sweats all over, has clammy feet and hands, grows excited or feels exhausted and faint; if there is anything unusual about the afterbirth; if the baby's skin is not soft and pink; if his cord stump bleeds; if he has any deformities or abnormalities; if he does not breathe easily and quietly.

The midwife must remember she "catches" the afterbirth; she does not pull it out or use her hands or fingers in any way to hurry or help it out.

It is important for the midwife to leave the mother and baby clean and warm and to be sure there is someone in the house who knows how to care for them until she comes again. She must be sure the baby **has had water and can nurse** before she leaves. She should leave directions on how to nurse the baby and how often he should be fed. She should not leave the house, even when everything seems all right, for at least 2 hours after the afterbirth is born, to be sure it is safe to leave the mother and baby.

## **Lesson XVI.**

### **A Practice Period**

For this lesson the supervisor should arrange extra practice in those procedures which the midwives have had difficulty in learning—probably tying, cutting, and dressing the cord and putting the drops into the baby's eyes. The equipment should be complete and correct, just as it has been described, for the procedures that will be practiced.

## Aftercare of the Mother and Baby

### TEN-MINUTE REVIEW

What can the midwife do if the mother bleeds **BEFORE** the afterbirth is expelled?

Can she do anything different if the bleeding comes **AFTER** the afterbirth is expelled?

What are the symptoms of concealed or internal bleeding?

How can the midwife tell that the afterbirth has separated?

What can the midwife do if the afterbirth does not come away?

What does the midwife do for the baby before the afterbirth?  
After that?

### What Mother and Baby Need

Explain that the mother and baby need to be kept clean, warm, and comfortable, to rest, to have the right food, to be watched for the beginning of any complication, and to be protected from infection. If either the mother or the baby is not well, the doctor will give special instructions. The following lesson covers the care of the **well** mother and baby.

### The Mother

#### Keeping the mother clean, warm, and comfortable.—

Explain that this means—

- A. A warm soap and water bath every day. After the first 24 hours the mother can bathe herself sitting up in bed. That much exercise is good for her and the moving about is restful. She will need help in washing her feet and her back. She will not touch nipples or vulva because they are cared for as described in lesson XV (pp. 122 and 124). Remind the midwife that brushing the teeth, using a mouthwash, combing the hair, and cleaning the nails are all part of the bath. Emphasize the importance of not letting the mother get chilled during the bath or at any other time.
- B. Clean clothes that have been washed, rinsed, boiled, and dried in the sun or ironed with a hot iron. A clean nightdress every day and whenever the one she is wearing becomes soiled.
- C. A clean bed. The sheets and newspaper pads and other bedclothes should be changed as often as they become soiled. The bedclothes

should be washed and boiled and should be dried in the sun or ironed with a hot iron.

- D.* A clean room that by the use of a damp broom and a damp dust cloth is kept clean without raising a dust and that has fresh air without drafts blowing on the mother or baby.

**Seeing that she rests.**—Explain to the family as well as to the mother why the mother needs to sleep as much as she can for the first few days after she has had a baby. Ask the family if they can and will help make it possible for the mother to have all the sleep she needs and 10 days in bed. The mother should lie quietly with her knees together for the first few hours and not sit up in bed for the first day. After that she can move about in bed as much as she likes. She should lie face down for 15 minutes twice a day to help the uterus return to its normal position. Having her bath and moving about when her bed is changed, when she uses the bedpan, when the vulva is washed, and when she nurses the baby will probably be as much as she will feel like doing for 3 to 5 days.

Visitors before the fifth day will disturb her rest, so that everyone but the family should stay away for the first week. She needs to stay in bed at least 8 days—10 days if possible. She should sit up in a chair for a short time the first day she gets up, for a longer time twice the next day. The next day she can begin to walk about the house. Then she can begin little by little to do a few things about the house and for the baby. The husband or some other member of the family or a friend should be there to do the housework until the mother is able to do it. The midwife should do everything she can in arranging to have the mother get the help she needs so that she can rest.

**The right food.**—Explain why the mother needs eight glasses of liquids every day. She needs food to keep up her strength and to make milk for the baby. The first day after the baby comes she can have toast, soft-cooked egg, cereal, cooked fruit, fruit juice, and ice cream. If her bowels move the next day, she can have regular meals such as she ate before the baby came. If her bowels do not move, she should stay on a soft diet.

**Watching for complications.**—Emphasize that the midwife must be on the lookout for any of the following symptoms:

- A.* Free bleeding.
- B.* Exhaustion.
- C.* Inability to pass water.
- D.* Constipation.
- E.* Diarrhea.

*F.* Childbed fever, the signs of which are—

- a.* Hot, dry skin with cold hands and feet, dry mouth, parched lips, flushed face.
- b.* No discharge from the birth canal, or discharge that is scant or too profuse, or has a foul odor.
- c.* Abdominal pain or tenderness.
- d.* Severe headache.
- e.* Swelling and tenderness of leg, sometimes called milk leg.

*G.* Breast difficulties:

- a.* No milk.
- b.* Caked breast.
- c.* Redness or tenderness of the breasts.
- d.* Cracked nipples.
- e.* Breast abscess.

*H.* Convulsions.

If any one of these symptoms appears, the midwife must report it to a doctor at once. The sooner any complication is treated the better are the mother's chances for recovery. The midwife should never wait a day or even an hour "to see if the trouble will clear up" before getting a doctor.

**Protecting her from infection.**—Explain that it is primarily the birth canal and the nipples from which disease germs must be kept away. Keeping everything around the mother clean helps to safeguard her from disease germs. Not touching the vulva with anything but the clean boiled wipes used in the special care of the vulva as described in lesson XV (p. 122) should keep anyone from transferring germs to the birth canal. Emphasize why the mother should keep her hands away from the vulva and should have no sexual intercourse until 6 weeks after delivery. The midwife should be sure that the husband also understands about the risks of intercourse too soon after the baby's birth.

Explain that to keep disease germs away from the nipples we depend on cleanliness—never touching the nipples except with a cotton swab dipped in boiled water just after the hands have been washed thoroughly, washing the nipples with swabs before and after each nursing, wearing clean nightgowns.

Explain that the mother needs protection too from any "catching" diseases. No one, whether a member of the family or a visitor, should be allowed in the mother's room if he has boils or other "sores" or if he is sick or has a cold or fever or has come from contact with someone else who is sick. The mother is more likely to catch diseases now than other people are, and her life may be in danger if this rule is broken.



## The Baby

**Keeping the baby clean, warm, and comfortable.**—Explain that the baby needs a warm-water sponge bath with a little soap every day after he is 24 hours old until the navel is healed. Then he can have his bath in a tub. The basin or tub that is used for the baby should be scrubbed clean and covered each day after he is bathed. Rinse it out well before he is bathed and fill with water that feels just warm to the elbow. Tell why it is important to have everything ready in a warm place before the baby is undressed and to handle him gently and quickly. His clothes and bedclothes must be changed often enough to keep them clean and dry. His room (the mother's room usually) should be kept clean without raising dust and warm but not hot and stuffy. Explain why he must not get chilled but should not be kept too warm. His hands and feet should always be warm, his skin pink and moist, and his breathing quiet and easy.

**Seeing that the baby gets rest.**—Explain why the new baby needs to sleep, in his own bed or basket, except when he is being bathed, having his clothes changed, or being fed. He should be handled as little as possible and always gently. His bed should be put where he will not be disturbed. If the weather is warm and he is protected from the wind and the bed is covered by a netting, he may be outdoors some of the time after he is 2 weeks old. He should be wakened only for his feedings and his bath. He needs exercise, too, and gets it from the handling when he is being cared for. He should have a chance after the first month to lie in his bed in a warm place without any clothes on so that he can kick and stretch for a few minutes every day.

**Feeding the baby.**—Explain again that until the milk comes the baby should nurse for only 5 minutes at each breast every 4 hours—at 6 and 10 o'clock in the morning, at 2 and 6 o'clock in the afternoon, and at 10 o'clock at night, and also at 2 o'clock at night if he wakes up. After the milk comes he should nurse at the same times but for 10 to 20 minutes each time (fig. 81). Between feedings—at 8 o'clock in the morning, at noon, and at 4 and 8 o'clock after noon—the baby should be given a drink of warm boiled water from a nursing bottle.

**Watching for complications.**—Emphasize the importance of noticing **at once** any of the following symptoms:

- A. Bleeding from nose, mouth, or bowels.
- B. Whining or moaning cry, hoarseness, cough, choking.
- C. Bad color—gray, white, or bluish.
- D. Baby does not breathe freely.



Fig. 81.—NURSING THE BABY.

- E.* Bleeding from the cord—blood stain on the front of the binder. Look at the back, too, because if the baby is lying on his back the blood may run around to the back.
- F.* Infection of the cord:
- a.* Cord stump becomes moist or has a bad odor.
  - b.* Redness appears at the navel.
  - c.* Swelling of the skin about the navel.
  - d.* Jaundice which is severe or lasts beyond the first week.
- G.* Infection of the eyes:
- a.* Pus and sticky secretion on eyelids.
  - b.* Swelling of eyelids.
  - c.* Redness of eyes.

*H.* Infection of the skin:

- a.* Rash.
- b.* Moist red patches on skin.
- c.* Scaling of palms of hands and soles of feet.
- d.* Tiny cracks about the anus.

*I.* Sore mouth:

- a.* Bleeding about lips or gums.
- b.* Rash in mouth—red or white pin dots.

*J.* Baby's bowels do not move.

*K.* Baby does not pass water.

*L.* Baby does not nurse.

*M.* Baby does not gain weight.

*N.* Baby vomits.

*O.* Diarrhea.

*P.* Snuffles or discharge from the nose.

*Q.* Convulsions or fits.

*R.* Any abnormality discovered about the baby's body.

Explain that any one of these symptoms means that the baby is not well and should be seen by a doctor at once. Babies can become dangerously sick in a very short time. Time lost in getting a doctor may mean a baby's life lost needlessly.

**Protecting the baby from infection.**—Explain why anyone who picks up the baby should wash the hands first. No one with a cold should go near the baby. If the mother has a cold, she should wear a mask when she does anything for the baby. Explain that kissing the baby should not be permitted.

Explain that the baby's eyes and cord are easily infected. They should not be touched. The eyelids may be wiped when the face is washed. The cord dressing should be changed only if it becomes very soiled, and the change should be made without touching the stump. The binder can be changed without disturbing the cord dressing. Nothing but a sterilized dressing should touch the navel until it has healed.

If it is necessary to change the cord dressing, the midwife should roll up her sleeves, open a sterile cord-dressing package part way, have a member of the family hold the baby with his clothes folded up over his arms and chest and one hand holding down his legs while she takes off the binder, scrubs her hands, and lifts off the soiled dressing without touching the stump. Then the clean sterile dressing should be put on just as it was done in lesson XIII (pp. 110–112).

Point out that the baby can put his hands to his eyes, so that his hands and everything that they can touch should be kept clean all the time. Recall that the discharges from the birth canal may have germs that would irritate the baby's eyes and cause blindness. Nothing that is soiled with the discharge should touch the baby or his clothes. The mother's hands, clothes, and bedclothes should be kept clean so that the baby cannot get any germs on his hands or in his eyes.

### SUMMARY

The midwife is responsible for seeing that the mother and her new baby have the watchful care that will safeguard their lives, that they are kept clean and comfortable, and that they have the rest and food they need. Her own rest will be more comfortable as long as she lives when she knows she has done everything—every least little thing—just as she has been taught to do it for every mother and baby she has cared for.

## Lesson XVIII.

### The Birth Certificate

#### A DEMONSTRATION AND PRACTICE PERIOD

#### TEN-MINUTE REVIEW

**Mention the important items in the care of a new mother and explain why each is important.**

**Mention each detail in the care of a new baby and explain why each is important.**

#### Purpose

To teach the midwife the importance of birth registration and how to fill in a birth-certificate blank.

#### Equipment

An enlarged copy of a birth-certificate blank on a sheet of white paper 60 inches long and 40 inches high fastened on the wall.

Several birth-certificate blanks.

Pencils.

#### Procedure

Explain the importance of birth registration to complete the country's count of its population and to furnish a permanent record from which each citizen can secure the proof of his age and citizenship.

Every State in the Union has a law that requires any person who attends a mother at childbirth to report the birth of the baby to the local registrar within a period ranging in different States from 3 to 10 days. Failure to do this properly is a punishable offense against the law. The proper blanks are furnished by the local registrar, and each midwife should keep a supply on hand.

The midwife should understand that proof of age is needed in connection with—

- A. Inheritance of property.
- B. Claims of widows and orphans.
- C. Settlement of insurance.
- D. Establishment of the right to pensions.
- E. The right to serve on a jury.

- F.* The right to enter school.
- G.* Military service.
- H.* The right to vote.
- I.* The right to marry.
- J.* A license to drive an automobile.
- K.* Employment in industry.

Proof of citizenship is needed in connection with—

- A.* Getting a passport.
- B.* Being exempted from military service in foreign countries.
- C.* Holding certain offices.
- D.* Being admitted to certain professions.
- E.* Being eligible for old-age assistance and other benefits from the Government (most States).

Explain that the birth certificate is a permanent record. It should be made out completely, accurately, neatly, with carefully formed, printed letters that can be read easily, and with unfading ink. Explain the meaning of each item on the certificate and show exactly how it should be filled in. Stress the reasons for each midwife's filling in the birth certificate before she leaves the house after the birth of the baby so that the registrar can have the record immediately. Send it immediately to the record office.

To make the State records complete all births must be reported, even those in which the baby is born dead.

Set up an imaginary situation and have each midwife who can read and write fill in a certificate. If a midwife can neither read nor write, have her tell how she would have the certificate made out for her.

### **Sample Situation**

A son, John Henry, was born to Mr. and Mrs. Thomas Henry Doe at their home on Caramel Hill, Bethlem, R. F. D. No. 1, Fairfield County, Miss., at 6:45 a. m., March 3, 1936.

Mrs. Doe was Mary Jane Smith before her marriage. Mrs. Doe was born in Jackson County, Miss., February 1909. She moved to Bethlem at the time of her marriage, June 1929. Mrs. Doe formerly taught school, but since her marriage has devoted all her talents to her home and children. Mrs. Doe has three living children: George, born in 1931; Harry, born in 1934; and the new baby, John Henry, born at 6:45 a. m. on March 3, 1936. Mary Helen, born in 1933, died of whooping cough at 3 months of age.

Mr. Thomas Henry Doe for 9 years has been the delivery man at a chain grocery store. Mr. Doe was born in Hale County, Miss., in 1904.

**SUMMARY**

Emphasize the midwife's legal duty to send the certificate of every birth to the local registrar promptly so that the baby can have proof of his age and citizenship when he needs it. The law requires every doctor, midwife, or parent to register births with the local registrar of vital statistics within a period ranging in different States from 3 to 10 days after the baby is born. The law requires that stillbirths as well as live births be reported.

## Lesson XIX.

### A Review

Go over the questions reviewed in each lesson, the most important points in each lesson, the summaries, and the list of antepartum and postpartum complications. Give the midwives an opportunity to ask questions about anything they have not understood or would like to have reviewed.



## Lesson XX.

### A Practice Period

During this period the midwives can practice those procedures they and the supervisor think need further work. The supervisor inspects each midwife's bag, commending her for the equipment that is in order or telling her quietly and individually what she must do to make her bag conform to the standard midwife equipment.



BOSTON PUBLIC LIBRARY



3 9999 05708 5829







